

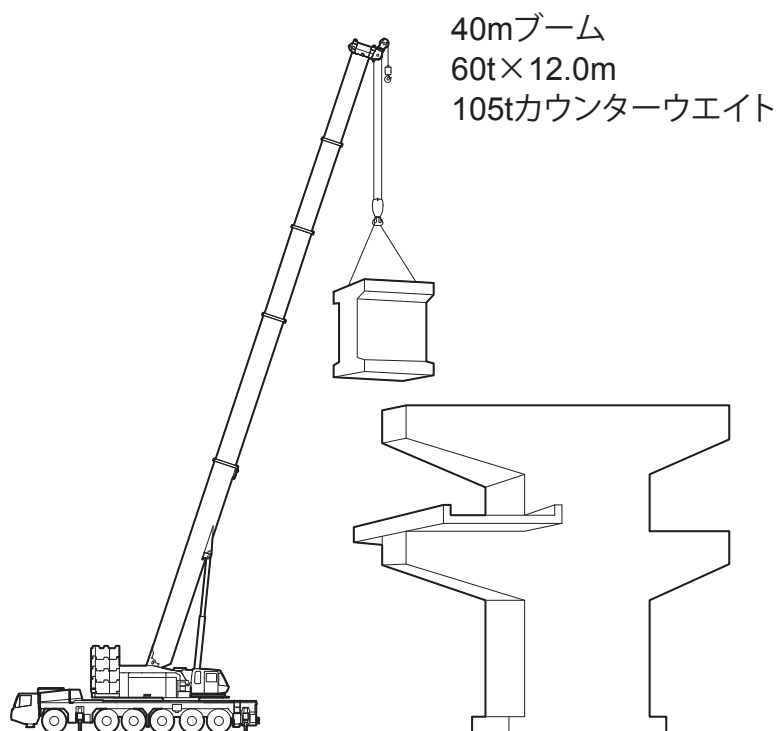

メインブーム作業概念図

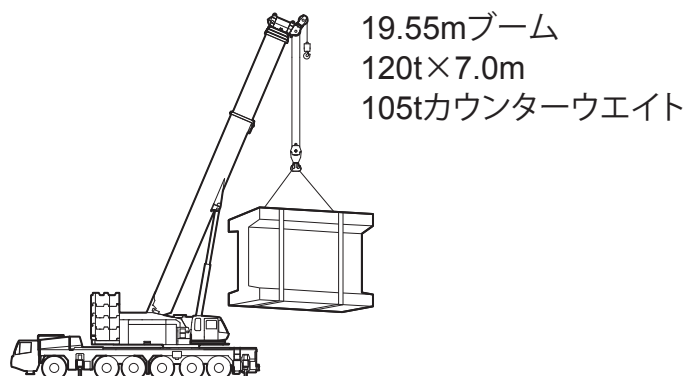



ブーム (重荷重装置) 作業範囲図

AA性能 カウンターウエイト 105t アウトリガー張出 8.4m

作業半径 (m)	14.4mブーム
2.5	*300.0
3.0	230.0
3.5	210.0
4.0	190.0
4.5	175.0
5.0	162.0
危険角度 (°)	—
フック種類	300t
フック質量 (t)	3.80
巻掛本数	14×2

(単位 : ton)

注) *印部性能は後方のみ
他は全周同一性能

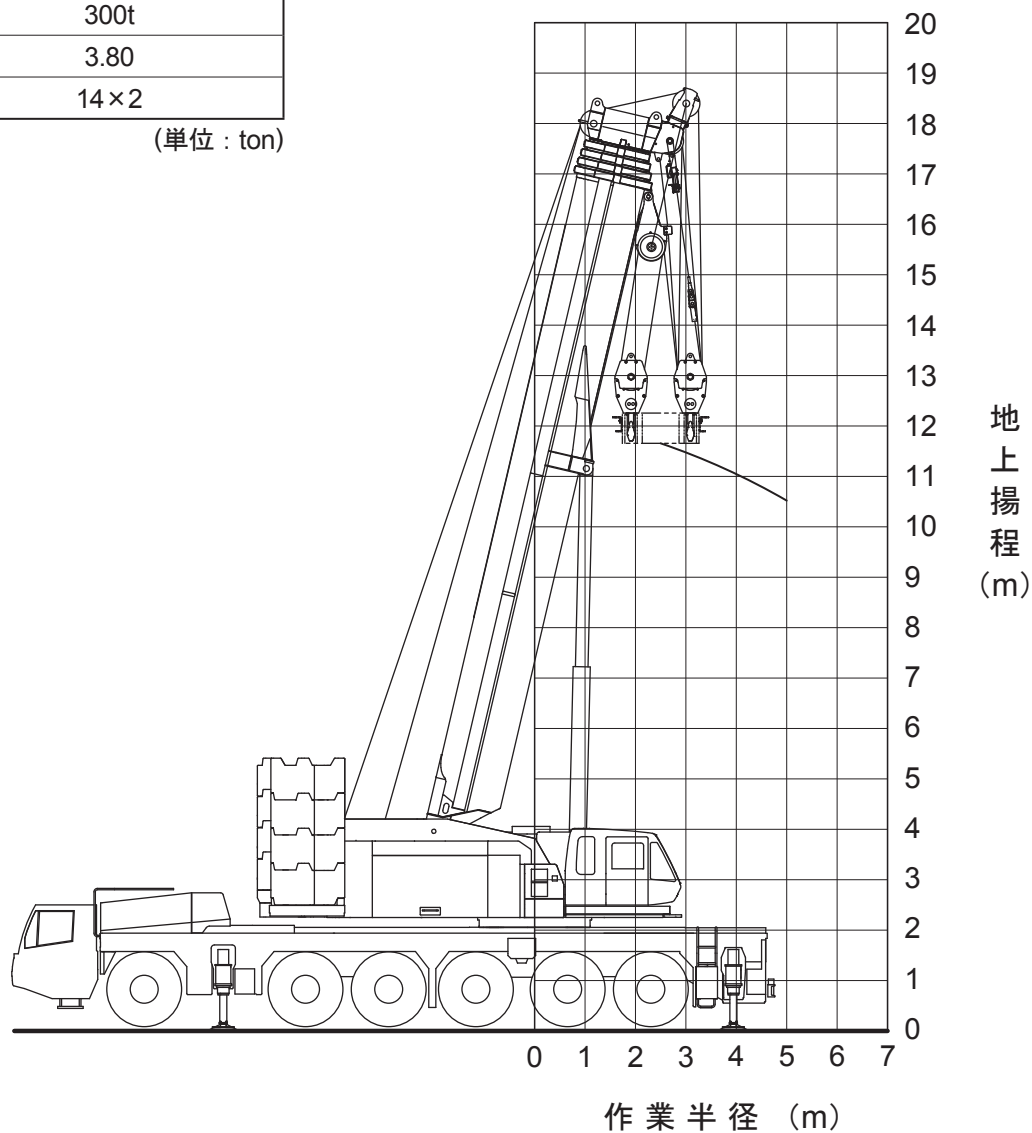

注. 本図は、ブームのたわみを含んでいません。



ブーム (重荷重装置) 作業範囲図

AA性能 カウンターウエイト 105t アウトリガー張出 8.4m

作業半径 (m)	14.4mブーム
2.5	*300.0
3.0	230.0
3.5	210.0
4.0	190.0
4.5	175.0
5.0	162.0
危険角度 (°)	—
フック種類	300t
フック質量 (t)	3.80
巻掛本数	14×2

(単位 : ton)

注) *印部性能は後方のみ
他は全周同一性能

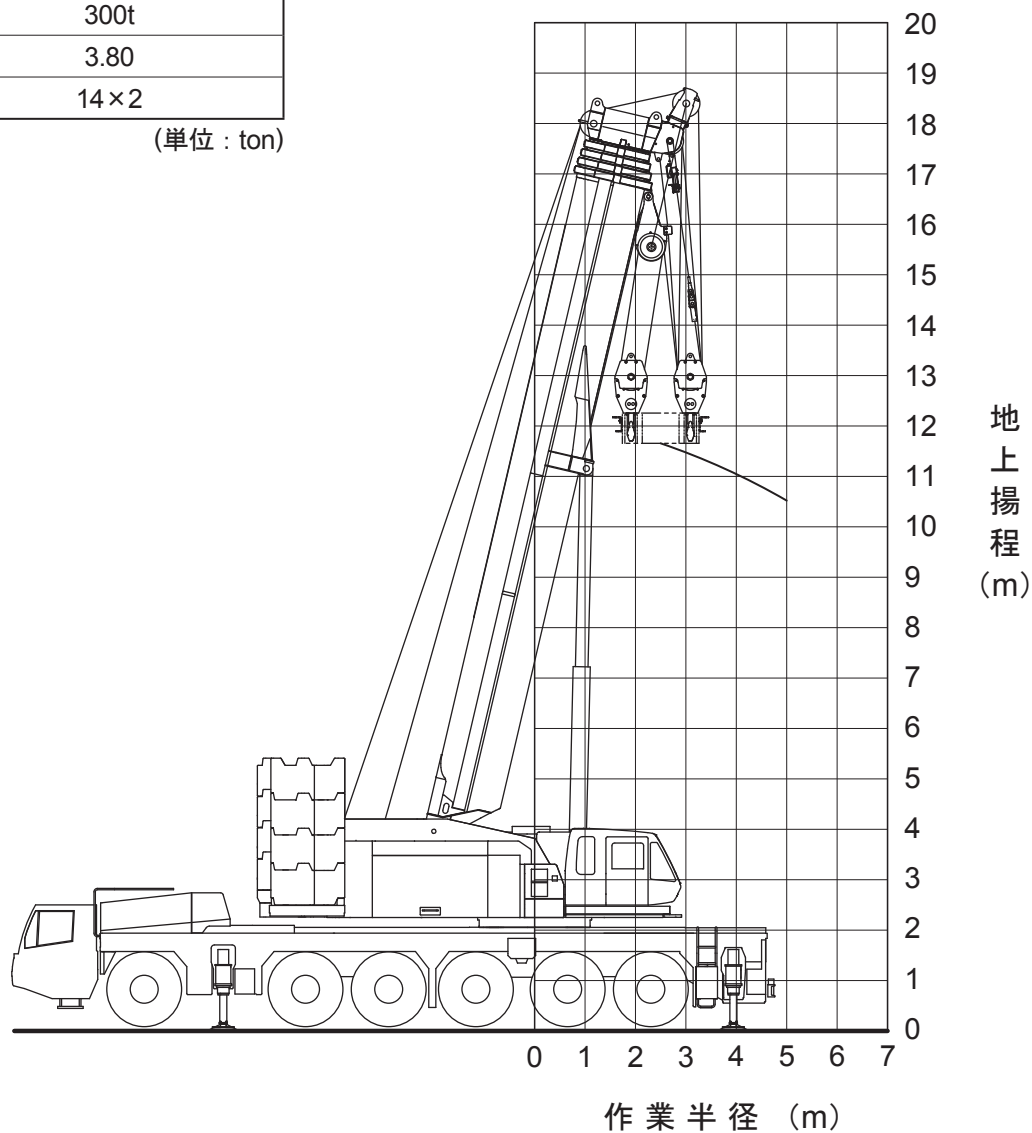

注. 本図は、ブームのたわみを含んでいません。



メインブーム【通常伸縮】作業範囲図

- Ⓐ 14.4 m ブーム
- Ⓑ 19.55 m ブーム
- Ⓒ 23.6 m ブーム
- Ⓓ 24.7 m ブーム
- Ⓔ 32.0 m ブーム
- Ⓕ 40.0 m ブーム
- Ⓖ 45.0 m ブーム
- Ⓗ 50.0 m ブーム
- Ⓘ 55.0 m ブーム
- Ⓙ 14.4 m ブーム+ルースターシーブ
- Ⓚ 19.55 m ブーム+ルースターシーブ
- Ⓛ 23.6 m ブーム+ルースターシーブ
- Ⓜ 24.7 m ブーム+ルースターシーブ
- Ⓝ 32.0 m ブーム+ルースターシーブ
- Ⓞ 40.0 m ブーム+ルースターシーブ
- Ⓟ 45.0 m ブーム+ルースターシーブ
- Ⓠ 50.0 m ブーム+ルースターシーブ
- Ⓡ 55.0 m ブーム+ルースターシーブ

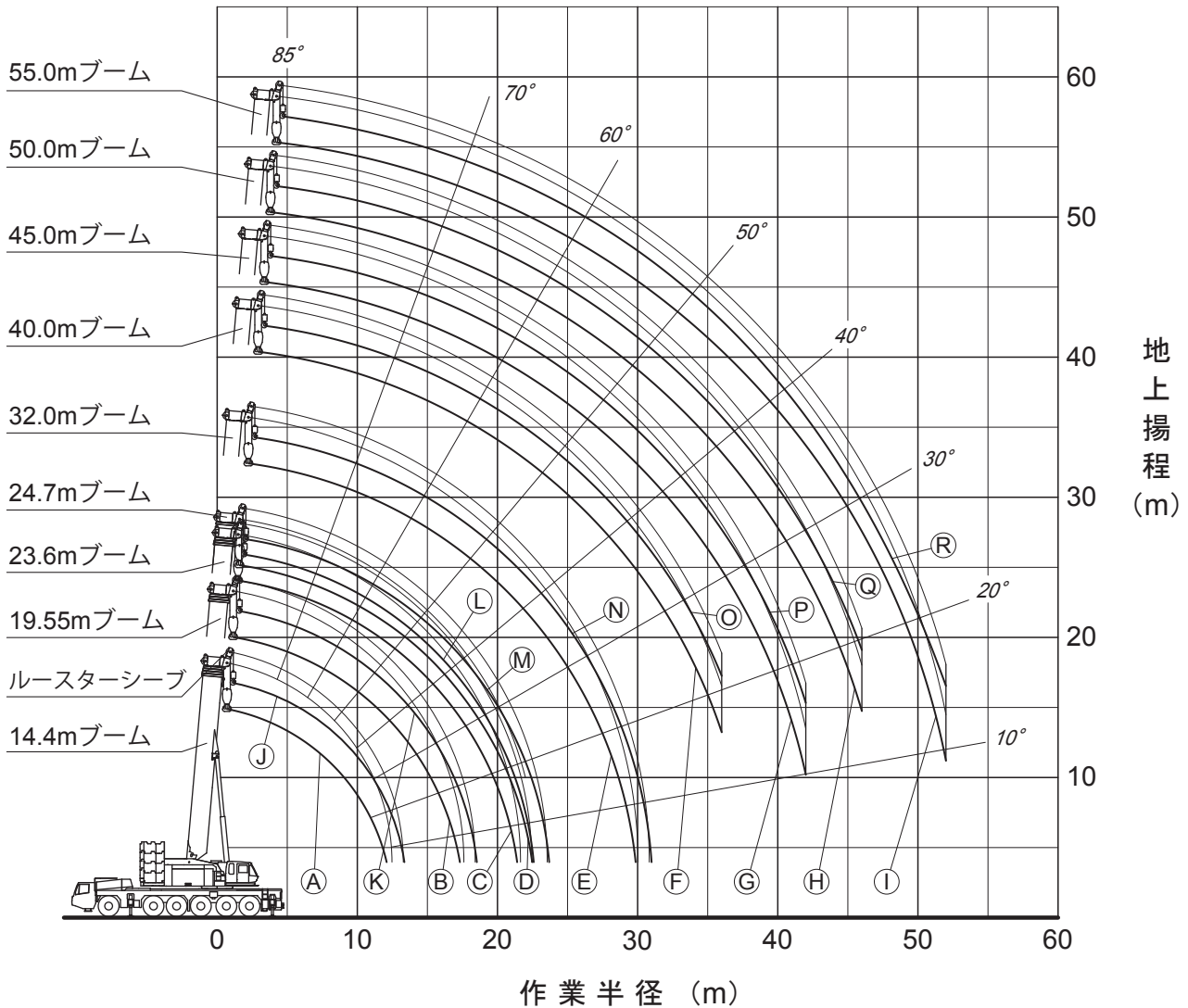

注1. 本図は、ブームのたわみを含んでいません。
 2. A1性能時のものを示してします。



14.4m — 55.0m

メインブーム【通常伸縮】

A1性能

カウンタウエイト 105t アウトリガ張出 9.4m (全周)

作業半径 (m)	14.4m ブーム	19.55m ブーム	23.6m ブーム	24.7m ブーム	32.0m ブーム	40.0m ブーム	45.0m ブーム	50.0m ブーム	55.0m ブーム
3.0	150.0								
3.5	150.0	120.0							
4.0	150.0	120.0	120.0	120.0					
4.5	150.0	120.0	120.0	120.0					
5.0	150.0	120.0	120.0	120.0	70.0				
6.0	144.9	120.0	120.0	120.0	70.0				
7.0	126.4	120.0	120.0	120.0	70.0	60.0			
8.0	111.8	110.1	109.2	109.0	70.0	60.0	47.0	38.0	
9.0	99.8	98.2	97.3	97.1	70.0	60.0	47.0	38.0	32.0
10.0	89.9	88.2	87.3	87.1	70.0	60.0	47.0	38.0	32.0
11.0	81.6	79.9	78.9	78.7	70.0	60.0	47.0	38.0	32.0
12.0	72.4	72.7	71.8	71.6	70.0	60.0	47.0	38.0	32.0
14.0		61.2	60.2	60.0	61.8	52.6	47.0	38.0	32.0
16.0		52.3	51.3	51.1	53.0	46.5	42.4	38.0	31.0
18.0			44.2	44.0	45.8	41.3	38.1	35.1	27.3
20.0			38.4	38.2	40.0	37.0	34.5	31.1	24.3
22.0				30.4	35.2	33.4	31.1	27.9	21.7
24.0					30.8	30.3	28.2	25.1	19.6
26.0					27.1	27.7	25.7	22.8	17.7
28.0					23.9	25.0	23.5	20.8	16.1
30.0						22.3	21.6	19.0	14.7
32.0						19.9	20.0	17.5	13.4
34.0						17.8	18.3	16.1	12.3
36.0						15.9	16.4	14.9	11.3
38.0							14.8	13.8	10.4
40.0							13.3	12.8	9.6
42.0							9.9	11.9	8.9
44.0								11.0	8.2
46.0								9.9	7.6
48.0									7.1
50.0									6.6
52.0									5.2
危険角度 (°)	—	—	—	—	—	2	3	5	7
フック種類	150t	150t	150t	150t	83t	83t	83t	83t	83t
フック質量 (t)	1.90	1.90	1.90	1.90	1.0	1.0	1.0	1.0	1.0
巻掛本数	14	12	12	12	7	6	4	4	4

(単位 : ton)

A2性能

カウンタウエイト 105t アウトリガ張出 8.4m (側方)

作業半径 (m)	14.4m ブーム	19.55m ブーム	23.6m ブーム	24.7m ブーム	32.0m ブーム	40.0m ブーム	45.0m ブーム	50.0m ブーム	55.0m ブーム
3.0	150.0								
3.5	150.0	120.0							
4.0	150.0	120.0	120.0	120.0					
4.5	150.0	120.0	120.0	120.0					
5.0	150.0	120.0	120.0	120.0	70.0				
6.0	144.9	120.0	120.0	120.0	70.0				
7.0	126.4	120.0	120.0	120.0	70.0	60.0			
8.0	111.8	110.1	109.2	109.0	70.0	60.0	47.0	38.0	
9.0	99.8	98.2	97.3	97.1	70.0	60.0	47.0	38.0	32.0
10.0	89.9	88.2	87.3	87.1	70.0	60.0	47.0	38.0	32.0
11.0	81.6	79.9	78.9	78.7	70.0	60.0	47.0	38.0	32.0
12.0	72.4	72.7	71.8	71.6	70.0	60.0	47.0	38.0	32.0
14.0		61.2	60.2	60.0	61.8	52.6	47.0	38.0	32.0
16.0		52.3	51.3	51.1	53.0	46.5	42.4	38.0	31.0
18.0			44.2	44.0	45.8	41.3	38.1	35.1	27.3
20.0			38.4	38.2	40.0	37.0	34.5	31.1	24.3
22.0				30.4	35.2	33.4	31.1	27.9	21.7
24.0					30.8	30.3	28.2	25.1	19.6
26.0					27.1	27.7	25.7	22.8	17.7
28.0					23.9	25.0	23.5	20.8	16.1
30.0						22.3	21.6	19.0	14.7
32.0						19.9	20.0	17.5	13.4
34.0						17.8	18.3	16.1	12.3
36.0						15.9	16.4	14.9	11.3
38.0							14.8	13.8	10.4
40.0							13.3	12.8	9.6
42.0							9.9	11.9	8.9
44.0								11.0	8.2
46.0								9.9	7.6
48.0									7.1
50.0									6.6
52.0									5.2
危険角度 (°)	—	—	—	—	—	2	3	5	7
フック種類	150t	150t	150t	150t	83t	83t	83t	83t	83t
フック質量 (t)	1.90	1.90	1.90	1.90	1.0	1.0	1.0	1.0	1.0
巻掛本数	14	12	12	12	7	6	4	4	4

(単位 : ton)



14.4m — 55.0m

メインブーム【通常伸縮】

B1性能

カウンタウエイト 93t アウトリガ張出 9.4m(全周)

作業半径 (m)	14.4m ブーム	19.55m ブーム	23.6m ブーム	24.7m ブーム	32.0m ブーム	40.0m ブーム	45.0m ブーム	50.0m ブーム	55.0m ブーム
3.0	150.0								
3.5	150.0	120.0							
4.0	150.0	120.0	120.0	120.0					
4.5	150.0	120.0	120.0	120.0					
5.0	150.0	120.0	120.0	120.0	70.0				
6.0	140.6	120.0	120.0	120.0	70.0				
7.0	122.6	120.0	120.0	120.0	70.0	60.0			
8.0	108.3	106.7	105.8	105.6	70.0	60.0	47.0	38.0	
9.0	96.7	95.1	94.2	93.9	70.0	60.0	47.0	38.0	32.0
10.0	87.1	85.4	84.5	84.3	70.0	60.0	47.0	38.0	32.0
11.0	79.0	77.2	76.3	76.1	70.0	60.0	47.0	38.0	32.0
12.0	72.1	70.3	69.4	69.2	70.0	60.0	47.0	38.0	32.0
14.0		59.0	58.1	57.9	59.8	52.6	47.0	38.0	32.0
16.0		50.4	49.4	49.2	51.1	46.5	42.4	38.0	31.0
18.0			42.0	41.8	43.9	41.3	38.1	35.1	27.3
20.0			35.8	35.6	37.6	37.0	34.5	31.1	24.3
22.0				30.4	32.5	33.4	31.1	27.9	21.7
24.0					28.3	29.4	28.2	25.1	19.6
26.0					24.7	25.9	25.7	22.8	17.7
28.0					21.7	22.8	23.5	20.8	16.1
30.0						20.2	20.9	19.0	14.7
32.0						17.9	18.5	17.5	13.4
34.0						16.0	16.5	16.1	12.3
36.0						14.2	14.7	14.9	11.3
38.0							13.2	13.5	10.4
40.0							11.7	12.1	9.6
42.0							9.9	10.8	8.9
44.0								9.6	8.2
46.0								8.6	7.6
48.0									7.1
50.0									6.6
52.0									5.2
危険角度(°)	—	—	—	—	—	2	3	5	7
フック種類	150t	150t	150t	150t	83t	83t	83t	83t	83t
フック質量(t)	1.90	1.90	1.90	1.90	1.0	1.0	1.0	1.0	1.0
巻掛本数	14	12	12	12	7	6	4	4	4

(単位 : ton)

B2性能

カウンタウエイト 93t アウトリガ張出 8.4m(側方)

作業半径 (m)	14.4m ブーム	19.55m ブーム	23.6m ブーム	24.7m ブーム	32.0m ブーム	40.0m ブーム	45.0m ブーム	50.0m ブーム	55.0m ブーム
3.0	150.0								
3.5	150.0	120.0							
4.0	150.0	120.0	120.0	120.0					
4.5	150.0	120.0	120.0	120.0					
5.0	150.0	120.0	120.0	120.0	70.0				
6.0	140.6	120.0	120.0	120.0	70.0				
7.0	122.6	120.0	120.0	120.0	70.0	60.0			
8.0	108.3	106.7	105.8	105.6	70.0	60.0	47.0	38.0	
9.0	96.7	95.1	94.2	93.9	70.0	60.0	47.0	38.0	32.0
10.0	87.1	85.4	84.5	84.3	70.0	60.0	47.0	38.0	32.0
11.0	79.0	77.2	76.3	76.1	70.0	60.0	47.0	38.0	32.0
12.0	72.1	70.3	69.4	69.2	70.0	60.0	47.0	38.0	32.0
14.0		59.0	58.1	57.9	59.8	52.6	47.0	38.0	32.0
16.0		50.4	49.4	49.2	51.1	46.5	42.4	38.0	31.0
18.0			42.0	41.8	43.9	41.3	38.1	35.1	27.3
20.0			35.8	35.6	37.6	37.0	34.5	31.1	24.3
22.0				30.4	32.5	33.4	31.1	27.9	21.7
24.0					28.3	29.4	28.2	25.1	19.6
26.0					24.7	25.9	25.7	22.8	17.7
28.0					21.7	22.8	23.5	20.8	16.1
30.0						20.2	20.9	19.0	14.7
32.0						17.9	18.5	17.5	13.4
34.0						16.0	16.5	16.1	12.3
36.0						14.2	14.7	14.9	11.3
38.0							13.2	13.5	10.4
40.0							11.7	12.1	9.6
42.0							9.9	10.8	8.9
44.0								9.6	8.2
46.0								8.6	7.6
48.0									7.1
50.0									6.6
52.0									5.2
危険角度(°)	—	—	—	—	—	2	3	5	7
フック種類	150t	150t	150t	150t	83t	83t	83t	83t	83t
フック質量(t)	1.90	1.90	1.90	1.90	1.0	1.0	1.0	1.0	1.0
巻掛本数	14	12	12	12	7	6	4	4	4

(単位 : ton)



14.4m — 55.0m

メインブーム【通常伸縮】

C1性能

カウンタウエイト 81t アウトリガ張出 9.4m(全周)

作業半径 (m)	14.4m ブーム	19.55m ブーム	23.6m ブーム	24.7m ブーム	32.0m ブーム	40.0m ブーム	45.0m ブーム	50.0m ブーム	55.0m ブーム
3.0	150.0								
3.5	150.0	120.0							
4.0	150.0	120.0	120.0	120.0					
4.5	150.0	120.0	120.0	120.0					
5.0	150.0	120.0	120.0	120.0	70.0				
6.0	136.3	120.0	120.0	120.0	70.0				
7.0	118.8	117.2	116.4	116.2	70.0	60.0			
8.0	104.9	103.3	102.4	102.2	70.0	60.0	47.0	38.0	
9.0	93.6	92.0	91.1	90.9	70.0	60.0	47.0	38.0	32.0
10.0	84.2	82.6	81.7	81.4	70.0	60.0	47.0	38.0	32.0
11.0	76.4	74.6	73.7	73.5	70.0	60.0	47.0	38.0	32.0
12.0	69.6	67.9	66.9	66.7	68.6	60.0	47.0	38.0	32.0
14.0		56.7	55.6	55.4	57.7	52.6	47.0	38.0	32.0
16.0		47.1	46.0	45.7	47.9	46.5	42.4	38.0	31.0
18.0			38.6	38.3	40.4	41.3	38.1	35.1	27.3
20.0			32.7	32.5	34.5	35.7	34.5	31.1	24.3
22.0				27.8	29.7	30.9	31.1	27.9	21.7
24.0					25.7	26.9	27.6	25.1	19.6
26.0					22.4	23.5	24.2	22.8	17.7
28.0					19.5	20.6	21.3	20.8	16.1
30.0						18.2	18.8	19.0	14.7
32.0						16.0	16.6	17.0	13.4
34.0						14.2	14.7	15.1	12.3
36.0						12.5	13.0	13.4	11.3
38.0							11.6	11.9	10.4
40.0							10.2	10.5	9.6
42.0							9.1	9.3	8.9
44.0								8.2	8.2
46.0								7.3	7.5
48.0									6.6
50.0									5.8
52.0									5.0
危険角度(°)	—	—	—	—	—	2	3	5	7
フック種類	150t	150t	150t	150t	83t	83t	83t	83t	83t
フック質量(t)	1.90	1.90	1.90	1.90	1.0	1.0	1.0	1.0	1.0
巻掛本数	14	12	12	12	7	6	4	4	4

(単位 : ton)

C2性能

カウンタウエイト 81t アウトリガ張出 8.4m(側方)

作業半径 (m)	14.4m ブーム	19.55m ブーム	23.6m ブーム	24.7m ブーム	32.0m ブーム	40.0m ブーム	45.0m ブーム	50.0m ブーム	55.0m ブーム
3.0	150.0								
3.5	150.0	120.0							
4.0	150.0	120.0	120.0	120.0					
4.5	150.0	120.0	120.0	120.0					
5.0	150.0	120.0	120.0	120.0	70.0				
6.0	136.3	120.0	120.0	120.0	70.0				
7.0	118.8	117.2	116.4	116.2	70.0	60.0			
8.0	104.9	103.3	102.4	102.2	70.0	60.0	47.0	38.0	
9.0	93.6	92.0	91.1	90.9	70.0	60.0	47.0	38.0	32.0
10.0	84.2	82.6	81.7	81.4	70.0	60.0	47.0	38.0	32.0
11.0	76.4	74.6	73.7	73.5	70.0	60.0	47.0	38.0	32.0
12.0	69.6	67.9	66.9	66.7	68.6	60.0	47.0	38.0	32.0
14.0		56.7	55.6	55.4	57.7	52.6	47.0	38.0	32.0
16.0		47.1	46.0	45.7	47.9	46.5	42.4	38.0	31.0
18.0			38.6	38.3	40.4	41.3	38.1	35.1	27.3
20.0			32.7	32.5	34.5	35.7	34.5	31.1	24.3
22.0				27.8	29.7	30.9	31.1	27.9	21.7
24.0					25.7	26.9	27.6	25.1	19.6
26.0					22.4	23.5	24.2	22.8	17.7
28.0					19.5	20.6	21.3	20.8	16.1
30.0						18.2	18.8	19.0	14.7
32.0						16.0	16.6	17.0	13.4
34.0						14.2	14.7	15.1	12.3
36.0						12.5	13.0	13.4	11.3
38.0							11.6	11.9	10.4
40.0							10.2	10.5	9.6
42.0							9.1	9.3	8.9
44.0								8.2	8.2
46.0								7.3	7.5
48.0									6.6
50.0									5.8
52.0									5.0
危険角度(°)	—	—	—	—	—	2	3	5	7
フック種類	150t	150t	150t	150t	83t	83t	83t	83t	83t
フック質量(t)	1.90	1.90	1.90	1.90	1.0	1.0	1.0	1.0	1.0
巻掛本数	14	12	12	12	7	6	4	4	4

(単位 : ton)



14.4m — 55.0m

メインブーム【通常伸縮】

D1性能

カウンタウエイト 69t アウトリガ張出 9.4m(全周)

作業半径 (m)	14.4m ブーム	19.55m ブーム	23.6m ブーム	24.7m ブーム	32.0m ブーム	40.0m ブーム	45.0m ブーム	50.0m ブーム	55.0m ブーム
3.0	150.0								
3.5	150.0	120.0							
4.0	150.0	120.0	120.0	120.0					
4.5	150.0	120.0	120.0	120.0					
5.0	150.0	120.0	120.0	120.0	70.0				
6.0	132.0	120.0	120.0	120.0	70.0				
7.0	115.0	113.4	112.5	112.3	70.0	60.0			
8.0	101.5	99.9	99.0	98.8	70.0	60.0	47.0	38.0	
9.0	90.5	88.9	88.0	87.8	70.0	60.0	47.0	38.0	32.0
10.0	81.4	79.7	78.8	78.6	70.0	60.0	47.0	38.0	32.0
11.0	73.7	72.0	71.1	70.9	70.0	60.0	47.0	38.0	32.0
12.0	66.6	64.5	63.4	63.1	65.5	60.0	47.0	38.0	32.0
14.0		52.2	51.1	50.9	53.1	52.6	47.0	38.0	32.0
16.0		43.2	42.1	41.8	44.0	45.3	42.4	38.0	31.0
18.0			35.1	34.9	37.0	38.2	38.1	35.1	27.3
20.0			29.6	29.4	31.4	32.6	33.4	31.1	24.3
22.0				25.0	26.9	28.1	28.8	27.9	21.7
24.0					23.1	24.3	25.0	25.1	19.6
26.0					20.0	21.2	21.8	22.2	17.7
28.0					17.3	18.5	19.1	19.5	16.1
30.0						16.1	16.8	17.1	14.7
32.0						14.1	14.7	15.1	13.4
34.0						12.4	12.9	13.3	12.3
36.0						10.8	11.3	11.7	11.3
38.0							9.9	10.3	10.4
40.0							8.7	9.0	9.2
42.0							7.6	7.9	8.1
44.0								6.9	7.1
46.0								5.9	6.1
48.0									5.3
50.0									4.5
52.0									3.9
危険角度(°)	—	—	—	—	—	2	3	5	7
フック種類	150t	150t	150t	150t	83t	83t	83t	83t	83t
フック質量(t)	1.90	1.90	1.90	1.90	1.0	1.0	1.0	1.0	1.0
巻掛本数	14	12	12	12	7	6	4	4	4

(単位 : ton)

D2性能

カウンタウエイト 69t アウトリガ張出 8.4m(側方)

作業半径 (m)	14.4m ブーム	19.55m ブーム	23.6m ブーム	24.7m ブーム	32.0m ブーム	40.0m ブーム	45.0m ブーム	50.0m ブーム	55.0m ブーム
3.0	150.0								
3.5	150.0	120.0							
4.0	150.0	120.0	120.0	120.0					
4.5	150.0	120.0	120.0	120.0					
5.0	150.0	120.0	120.0	120.0	70.0				
6.0	132.0	120.0	120.0	120.0	70.0				
7.0	115.0	113.4	112.5	112.3	70.0	60.0			
8.0	101.5	99.9	99.0	98.8	70.0	60.0	47.0	38.0	
9.0	90.5	88.9	88.0	87.8	70.0	60.0	47.0	38.0	32.0
10.0	81.4	79.7	78.8	78.6	70.0	60.0	47.0	38.0	32.0
11.0	73.7	72.0	71.1	70.9	70.0	60.0	47.0	38.0	32.0
12.0	66.6	64.5	63.4	63.1	65.5	60.0	47.0	38.0	32.0
14.0		52.2	51.1	50.9	53.1	52.6	47.0	38.0	32.0
16.0		43.2	42.1	41.8	44.0	45.3	42.4	38.0	31.0
18.0			35.1	34.9	37.0	38.2	38.1	35.1	27.3
20.0			29.6	29.4	31.4	32.6	33.4	31.1	24.3
22.0				25.0	26.9	28.1	28.8	27.9	21.7
24.0					23.1	24.3	25.0	25.1	19.6
26.0					20.0	21.2	21.8	22.2	17.7
28.0					17.3	18.5	19.1	19.5	16.1
30.0						16.1	16.8	17.1	14.7
32.0						14.1	14.7	15.1	13.4
34.0						12.4	12.9	13.3	12.3
36.0						10.8	11.3	11.7	11.3
38.0							9.9	10.3	10.4
40.0							8.7	9.0	9.2
42.0							7.6	7.9	8.1
44.0								6.9	7.1
46.0								5.9	6.1
48.0									5.3
50.0									4.5
52.0									3.9
危険角度(°)	—	—	—	—	—	2	3	5	7
フック種類	150t	150t	150t	150t	83t	83t	83t	83t	83t
フック質量(t)	1.90	1.90	1.90	1.90	1.0	1.0	1.0	1.0	1.0
巻掛本数	14	12	12	12	7	6	4	4	4

(単位 : ton)



14.4m — 55.0m

メインブーム【通常伸縮】

D3性能

カウンタウエイト 69t アウトリガ張出 7.4m (側方)

作業半径 (m)	14.4m ブーム	19.55m ブーム	23.6m ブーム	24.7m ブーム	32.0m ブーム	40.0m ブーム	45.0m ブーム	50.0m ブーム	55.0m ブーム
3.0	150.0								
3.5	150.0	120.0							
4.0	150.0	120.0	120.0	120.0					
4.5	150.0	120.0	120.0	120.0					
5.0	150.0	120.0	120.0	120.0	70.0				
6.0	132.0	120.0	120.0	120.0	70.0				
7.0	115.0	113.4	112.5	112.3	70.0	60.0			
8.0	101.5	99.9	99.0	98.8	70.0	60.0	47.0	38.0	
9.0	90.5	88.9	87.9	87.8	70.0	60.0	47.0	38.0	32.0
10.0	81.4	79.7	78.8	78.6	70.0	60.0	47.0	38.0	32.0
11.0	73.7	72.0	71.1	70.9	70.0	60.0	47.0	38.0	32.0
12.0	66.3	64.4	63.4	63.1	65.3	60.0	47.0	38.0	32.0
14.0		49.5	48.6	48.4	50.3	51.4	47.0	38.0	32.0
16.0		39.5	38.6	38.4	40.2	41.3	41.9	38.0	31.0
18.0			31.4	31.2	33.0	34.0	34.6	34.9	27.3
20.0			26.1	25.9	27.5	28.5	29.0	29.3	24.3
22.0				21.7	23.2	24.2	24.7	25.0	21.7
24.0					19.8	20.7	21.3	21.5	19.6
26.0					17.0	17.9	18.4	18.7	17.7
28.0					14.7	15.6	16.0	16.3	16.1
30.0						13.6	14.0	14.3	14.5
32.0						11.9	12.3	12.6	12.8
34.0						10.4	10.8	11.1	11.3
36.0						9.2	9.5	9.8	10.0
38.0							8.4	8.6	8.8
40.0							7.4	7.6	7.8
42.0							6.5	6.7	6.9
44.0								5.8	6.1
46.0								4.9	5.1
48.0									4.2
50.0									3.5
危険角度 (°)	—	—	—	—	—	2	3	5	15
フック種類	150t	150t	150t	150t	83t	83t	83t	83t	83t
フック質量 (t)	1.90	1.90	1.90	1.90	1.0	1.0	1.0	1.0	1.0
巻掛本数	14	12	12	12	7	6	4	4	4

(単位 : ton)



14.4m — 55.0m

メインブーム【通常伸縮】

E1性能

カウンタウエイト 51t アウトリガ張出 9.4m (全周)

作業半径 (m)	14.4m ブーム	19.55m ブーム	23.6m ブーム	24.7m ブーム	32.0m ブーム	40.0m ブーム	45.0m ブーム	50.0m ブーム	55.0m ブーム
3.0	150.0								
3.5	150.0	120.0							
4.0	150.0	120.0	120.0	120.0					
4.5	150.0	120.0	120.0	120.0					
5.0	146.7	120.0	120.0	120.0	70.0				
6.0	125.5	120.0	120.0	120.0	70.0				
7.0	109.3	107.7	106.8	106.6	70.0	60.0			
8.0	96.3	94.7	93.8	93.6	70.0	60.0	47.0	38.0	
9.0	85.1	83.1	82.0	81.7	70.0	60.0	47.0	38.0	32.0
10.0	74.4	72.4	71.3	71.0	70.0	60.0	47.0	38.0	32.0
11.0	65.8	63.7	62.6	62.4	64.7	60.0	47.0	38.0	32.0
12.0	58.7	56.6	55.5	55.3	57.6	58.9	47.0	38.0	32.0
14.0		45.5	44.4	44.2	46.4	47.7	47.0	38.0	32.0
16.0		37.3	36.2	36.0	38.2	39.4	40.2	38.0	31.0
18.0			29.9	29.7	31.8	33.0	33.8	34.2	27.3
20.0			25.0	24.7	26.8	28.0	28.7	29.1	24.3
22.0				20.8	22.7	23.9	24.6	24.9	21.7
24.0					19.3	20.5	21.2	21.5	19.6
26.0					16.4	17.6	18.3	18.6	17.7
28.0					14.1	15.2	15.8	16.2	16.1
30.0						13.1	13.7	14.0	14.3
32.0						11.2	11.8	12.2	12.5
34.0						9.7	10.2	10.6	10.8
36.0						8.3	8.8	9.1	9.4
38.0							7.5	7.9	8.1
40.0							6.4	6.7	7.0
42.0							5.4	5.7	5.9
44.0								4.8	5.0
46.0								4.0	4.1
48.0									3.4
危険角度 (°)	—	—	—	—	—	2	3	5	22
フック種類	150t	150t	150t	150t	83t	83t	83t	83t	83t
フック質量 (t)	1.90	1.90	1.90	1.90	1.0	1.0	1.0	1.0	1.0
巻掛本数	14	12	12	12	7	6	4	4	4

(単位 : ton)

E2性能

カウンタウエイト 51t アウトリガ張出 8.4m (側方)

作業半径 (m)	14.4m ブーム	19.55m ブーム	23.6m ブーム	24.7m ブーム	32.0m ブーム	40.0m ブーム	45.0m ブーム	50.0m ブーム	55.0m ブーム
3.0	150.0								
3.5	150.0	120.0							
4.0	150.0	120.0	120.0	120.0					
4.5	150.0	120.0	120.0	120.0					
5.0	146.7	120.0	120.0	120.0	70.0				
6.0	125.5	120.0	120.0	120.0	70.0				
7.0	109.3	107.7	106.8	106.6	70.0	60.0			
8.0	96.3	94.7	93.8	93.6	70.0	60.0	47.0	38.0	
9.0	85.1	83.1	82.0	81.7	70.0	60.0	47.0	38.0	32.0
10.0	74.4	72.4	71.3	71.0	70.0	60.0	47.0	38.0	32.0
11.0	65.8	63.7	62.6	62.4	64.7	60.0	47.0	38.0	32.0
12.0	58.7	56.6	55.5	55.3	57.6	58.9	47.0	38.0	32.0
14.0		45.5	44.4	44.2	46.4	47.7	47.0	38.0	32.0
16.0		37.3	36.2	36.0	38.2	39.4	40.2	38.0	31.0
18.0			29.9	29.7	31.8	33.0	33.8	34.2	27.3
20.0			25.0	24.7	26.8	28.0	28.7	29.1	24.3
22.0				20.8	22.7	23.7	24.3	24.6	21.7
24.0					19.1	20.1	20.7	21.0	19.6
26.0					16.3	17.2	17.8	18.1	17.7
28.0					13.9	14.8	15.4	15.7	15.9
30.0						12.8	13.3	13.6	13.8
32.0						11.1	11.6	11.8	12.1
34.0						9.6	10.0	10.3	10.5
36.0						8.1	8.7	9.0	9.2
38.0							7.3	7.7	7.9
40.0							6.1	6.4	6.7
42.0							5.0	5.3	5.6
44.0								4.3	4.6
46.0								3.4	3.7
危険角度 (°)	—	—	—	—	—	2	3	5	28
フック種類	150t	150t	150t	150t	83t	83t	83t	83t	83t
フック質量 (t)	1.90	1.90	1.90	1.90	1.0	1.0	1.0	1.0	1.0
巻掛本数	14	12	12	12	7	6	4	4	4

(単位 : ton)



14.4m — 55.0m

メインブーム【通常伸縮】

E3性能

カウンタウエイト 51t アウトリガ張出 7.4m (側方)

作業半径 (m)	14.4m ブーム	19.55m ブーム	23.6m ブーム	24.7m ブーム	32.0m ブーム	40.0m ブーム	45.0m ブーム	50.0m ブーム	55.0m ブーム
3.0	150.0								
3.5	150.0	120.0							
4.0	150.0	120.0	120.0	120.0					
4.5	150.0	120.0	120.0	120.0					
5.0	146.7	120.0	120.0	120.0	70.0				
6.0	125.5	120.0	120.0	120.0	70.0				
7.0	109.3	107.7	106.8	106.6	70.0	60.0			
8.0	96.3	94.7	93.8	93.6	70.0	60.0	47.0	38.0	
9.0	85.1	83.1	82.0	81.7	70.0	60.0	47.0	38.0	32.0
10.0	74.4	72.4	71.3	71.0	70.0	60.0	47.0	38.0	32.0
11.0	63.3	61.3	60.3	60.1	62.3	60.0	47.0	38.0	32.0
12.0	54.4	52.5	51.5	51.3	53.4	54.6	47.0	38.0	32.0
14.0		39.9	39.0	38.8	40.7	41.8	42.5	38.0	32.0
16.0		31.5	30.6	30.4	32.2	33.2	33.9	34.2	31.0
18.0			24.5	24.3	26.1	27.1	27.7	28.0	27.3
20.0			20.0	19.8	21.4	22.4	23.0	23.3	23.5
22.0				16.3	17.8	18.8	19.3	19.6	19.8
24.0					14.9	15.9	16.4	16.7	16.9
26.0					12.6	13.5	14.0	14.3	14.5
28.0					10.6	11.5	12.0	12.2	12.4
30.0						9.8	10.3	10.5	10.7
32.0						8.4	8.8	9.1	9.3
34.0						7.1	7.6	7.8	8.0
36.0						6.0	6.5	6.7	6.9
38.0							5.3	5.6	5.9
40.0							4.2	4.5	4.8
42.0							3.2	3.5	3.8
危険角度 (°)	—	—	—	—	—	2	3	26	36
フック種類	150t	150t	150t	150t	83t	83t	83t	83t	83t
フック質量 (t)	1.90	1.90	1.90	1.90	1.0	1.0	1.0	1.0	1.0
巻掛本数	14	12	12	12	7	6	4	4	4

(単位 : ton)



14.4m — 55.0m

メインブーム【通常伸縮】

F1性能

カウンタウエイト 41t アウトリガ張出 9.4m (全周)

作業半径 (m)	14.4m ブーム	19.55m ブーム	23.6m ブーム	24.7m ブーム	32.0m ブーム	40.0m ブーム	45.0m ブーム	50.0m ブーム	55.0m ブーム
3.0	150.0								
3.5	150.0	120.0							
4.0	150.0	120.0	120.0	120.0					
4.5	150.0	120.0	120.0	120.0					
5.0	141.8	120.0	120.0	120.0	70.0				
6.0	121.4	119.8	118.9	118.7	70.0				
7.0	105.6	104.0	103.1	102.9	70.0	60.0			
8.0	91.4	89.3	88.2	87.9	70.0	60.0	47.0	38.0	
9.0	78.7	76.6	75.5	75.3	70.0	60.0	47.0	38.0	32.0
10.0	68.6	66.6	65.5	65.3	67.6	60.0	47.0	38.0	32.0
11.0	60.6	58.5	57.4	57.2	59.5	60.0	47.0	38.0	32.0
12.0	53.9	51.8	50.7	50.5	52.8	54.1	47.0	38.0	32.0
14.0		41.4	40.4	40.1	42.4	43.6	44.4	38.0	32.0
16.0		33.8	32.7	32.5	34.6	35.9	36.7	37.0	31.0
18.0			26.8	26.6	28.7	29.9	30.7	31.0	27.3
20.0			22.2	21.9	23.9	25.2	25.9	26.3	24.3
22.0				18.2	20.1	21.3	22.0	22.4	21.7
24.0					16.9	18.1	18.8	19.2	19.5
26.0					14.3	15.4	16.1	16.5	16.8
28.0					12.1	13.2	13.8	14.2	14.4
30.0						11.2	11.8	12.2	12.4
32.0						9.5	10.1	10.4	10.7
34.0						8.0	8.6	8.9	9.2
36.0						6.7	7.2	7.6	7.8
38.0							6.1	6.4	6.6
40.0							5.0	5.3	5.6
42.0							4.1	4.4	4.6
44.0								3.5	3.7
危険角度 (°)	—	—	—	—	—	2	3	20	32
フック種類	150t	150t	150t	150t	83t	83t	83t	83t	83t
フック質量 (t)	1.90	1.90	1.90	1.90	1.0	1.0	1.0	1.0	1.0
巻掛本数	14	12	12	12	7	6	4	4	4

(単位 : ton)

F2性能

カウンタウエイト 41t アウトリガ張出 8.4m (側方)

作業半径 (m)	14.4m ブーム	19.55m ブーム	23.6m ブーム	24.7m ブーム	32.0m ブーム	40.0m ブーム	45.0m ブーム	50.0m ブーム	55.0m ブーム
3.0	150.0								
3.5	150.0	120.0							
4.0	150.0	120.0	120.0	120.0					
4.5	150.0	120.0	120.0	120.0					
5.0	141.8	120.0	120.0	120.0	70.0				
6.0	121.4	119.8	118.9	118.7	70.0				
7.0	105.6	104.0	103.1	102.9	70.0	60.0			
8.0	91.4	89.3	88.2	87.9	70.0	60.0	47.0	38.0	
9.0	78.7	76.6	75.5	75.3	70.0	60.0	47.0	38.0	32.0
10.0	68.6	66.6	65.5	65.3	67.6	60.0	47.0	38.0	32.0
11.0	60.6	58.5	57.4	57.2	59.5	60.0	47.0	38.0	32.0
12.0	53.9	51.8	50.7	50.5	52.8	54.1	47.0	38.0	32.0
14.0		41.4	40.4	40.1	42.4	43.6	44.4	38.0	32.0
16.0		33.8	32.7	32.5	34.6	35.9	36.7	37.0	31.0
18.0			26.4	26.1	28.1	29.2	29.8	30.2	27.3
20.0			21.4	21.1	22.9	24.0	24.6	25.0	24.3
22.0				17.3	19.0	20.0	20.6	20.9	21.2
24.0					15.8	16.8	17.4	17.7	17.9
26.0					13.2	14.2	14.8	15.1	15.3
28.0					11.1	12.1	12.6	12.9	13.1
30.0						10.2	10.8	11.0	11.3
32.0						8.6	9.2	9.5	9.7
34.0						7.0	7.6	8.0	8.3
36.0						5.6	6.2	6.6	6.8
38.0							4.9	5.3	5.6
40.0							3.8	4.2	4.4
42.0								3.2	3.4
危険角度 (°)	—	—	—	—	—	2	16	29	37
フック種類	150t	150t	150t	150t	83t	83t	83t	83t	83t
フック質量 (t)	1.90	1.90	1.90	1.90	1.0	1.0	1.0	1.0	1.0
巻掛本数	14	12	12	12	7	6	4	4	4

(単位 : ton)



14.4m — 55.0m

メインブーム【通常伸縮】

F3性能

カウンタウエイト 41t アウトリガ張出 7.4m (側方)

作業半径 (m)	14.4m ブーム	19.55m ブーム	23.6m ブーム	24.7m ブーム	32.0m ブーム	40.0m ブーム	45.0m ブーム	50.0m ブーム	55.0m ブーム
3.0	150.0								
3.5	150.0	120.0							
4.0	150.0	120.0	120.0	120.0					
4.5	150.0	120.0	120.0	120.0					
5.0	141.8	120.0	120.0	120.0	70.0				
6.0	121.4	119.8	118.9	118.7	70.0				
7.0	105.6	104.0	103.1	102.9	70.0	60.0			
8.0	91.4	89.3	88.2	87.9	70.0	60.0	47.0	38.0	
9.0	78.7	76.6	75.5	75.3	70.0	60.0	47.0	38.0	32.0
10.0	65.8	63.8	62.7	62.5	64.9	60.0	47.0	38.0	32.0
11.0	55.3	53.4	52.4	52.1	54.3	55.6	47.0	38.0	32.0
12.0	47.4	45.5	44.5	44.3	46.4	47.6	47.0	38.0	32.0
14.0		34.3	33.3	33.1	35.1	36.2	36.9	37.2	32.0
16.0		26.8	25.9	25.6	27.5	28.5	29.2	29.5	29.7
18.0			20.5	20.3	22.0	23.0	23.6	23.9	24.1
20.0			16.5	16.2	17.9	18.8	19.4	19.7	19.9
22.0				13.1	14.7	15.6	16.2	16.4	16.7
24.0					12.1	13.0	13.5	13.8	14.0
26.0					10.0	10.9	11.4	11.7	11.9
28.0					8.3	9.1	9.6	9.9	10.1
30.0						7.6	8.1	8.3	8.5
32.0						6.3	6.8	7.0	7.2
34.0						4.8	5.4	5.8	6.1
36.0						3.6	4.2	4.5	4.8
38.0							3.1	3.4	3.7
危険角度 (°)	—	—	—	—	—	10	28	37	44
フック種類	150t	150t	150t	150t	83t	83t	83t	83t	83t
フック質量 (t)	1.90	1.90	1.90	1.90	1.0	1.0	1.0	1.0	1.0
巻掛本数	14	12	12	12	7	6	4	4	4

(単位 : ton)

F4性能

カウンタウエイト 41t アウトリガ張出 6.4m (側方)

作業半径 (m)	14.4m ブーム	19.55m ブーム	23.6m ブーム	24.7m ブーム	32.0m ブーム	40.0m ブーム	45.0m ブーム	50.0m ブーム	55.0m ブーム
3.0	150.0								
3.5	150.0	120.0							
4.0	150.0	120.0	120.0	120.0					
4.5	150.0	120.0	120.0	120.0					
5.0	141.8	120.0	120.0	120.0	70.0				
6.0	121.4	119.8	118.9	118.7	70.0				
7.0	105.6	103.3	102.0	101.7	70.0	60.0			
8.0	81.3	79.2	78.0	77.8	70.0	60.0	47.0	38.0	
9.0	65.4	63.4	62.3	62.1	64.4	60.0	47.0	38.0	32.0
10.0	54.1	52.2	51.2	51.0	53.2	54.4	47.0	38.0	32.0
11.0	45.8	44.0	43.0	42.8	44.9	46.0	46.8	38.0	32.0
12.0	39.4	37.6	36.7	36.4	38.4	39.6	40.3	38.0	32.0
14.0		28.4	27.5	27.3	29.1	30.2	30.8	31.2	31.4
16.0		22.1	21.2	21.0	22.7	23.8	24.4	24.7	24.9
18.0			16.6	16.4	18.1	19.1	19.7	19.9	20.2
20.0			13.2	13.0	14.6	15.5	16.1	16.3	16.6
22.0				10.3	11.8	12.7	13.2	13.5	13.7
24.0					9.5	10.4	11.0	11.2	11.4
26.0					7.7	8.6	9.1	9.3	9.5
28.0					6.0	7.0	7.5	7.8	8.0
30.0						5.5	6.1	6.4	6.6
32.0						4.0	4.6	5.0	5.3
34.0							3.3	3.7	4.0
危険角度 (°)	—	—	—	—	—	33	38	45	50
フック種類	150t	150t	150t	150t	83t	83t	83t	83t	83t
フック質量 (t)	1.90	1.90	1.90	1.90	1.0	1.0	1.0	1.0	1.0
巻掛本数	14	12	12	12	7	6	4	4	4

(単位 : ton)



14.4m — 55.0m

メインブーム【通常伸縮】

G1性能

カウンタウエイト 31t アウトリガ張出 9.4m (全周)

作業半径 (m)	14.4m ブーム	19.55m ブーム	23.6m ブーム	24.7m ブーム	32.0m ブーム	40.0m ブーム	45.0m ブーム	50.0m ブーム	55.0m ブーム
3.0	150.0								
3.5	150.0	120.0							
4.0	150.0	120.0	120.0	120.0					
4.5	149.3	120.0	120.0	120.0					
5.0	137.0	120.0	120.0	120.0	70.0				
6.0	117.2	115.6	114.8	114.6	70.0				
7.0	99.5	97.5	96.3	96.1	70.0	60.0			
8.0	84.0	82.0	80.9	80.6	70.0	60.0	47.0	38.0	
9.0	72.2	70.2	69.1	68.8	70.0	60.0	47.0	38.0	32.0
10.0	62.9	60.8	59.7	59.5	61.9	60.0	47.0	38.0	32.0
11.0	55.3	53.3	52.2	51.9	54.3	55.6	47.0	38.0	32.0
12.0	49.1	47.0	46.0	45.7	48.0	49.3	47.0	38.0	32.0
14.0		37.4	36.3	36.1	38.3	39.6	40.4	38.0	32.0
16.0		30.2	29.2	28.9	31.1	32.3	33.1	33.5	31.0
18.0			23.7	23.4	25.5	26.8	27.5	27.9	27.3
20.0			19.4	19.1	21.1	22.4	23.1	23.5	23.7
22.0				15.6	17.6	18.8	19.5	19.8	20.1
24.0					14.6	15.8	16.5	16.8	17.1
26.0					12.1	13.3	14.0	14.3	14.6
28.0					10.1	11.2	11.8	12.2	12.4
30.0						9.3	10.0	10.3	10.6
32.0						7.8	8.4	8.7	9.0
34.0						6.3	6.9	7.3	7.5
36.0						5.0	5.6	5.9	6.2
38.0							4.3	4.7	5.0
40.0							3.2	3.6	3.9
危険角度 (°)	—	—	—	—	—	2	20	33	40
フック種類	150t	150t	150t	150t	83t	83t	83t	83t	83t
フック質量 (t)	1.90	1.90	1.90	1.90	1.0	1.0	1.0	1.0	1.0
巻掛本数	14	12	12	12	7	6	4	4	4

(単位 : ton)

G2性能

カウンタウエイト 31t アウトリガ張出 8.4m (側方)

作業半径 (m)	14.4m ブーム	19.55m ブーム	23.6m ブーム	24.7m ブーム	32.0m ブーム	40.0m ブーム	45.0m ブーム	50.0m ブーム	55.0m ブーム
3.0	150.0								
3.5	150.0	120.0							
4.0	150.0	120.0	120.0	120.0					
4.5	149.3	120.0	120.0	120.0					
5.0	137.0	120.0	120.0	120.0	70.0				
6.0	117.2	115.6	114.8	114.6	70.0				
7.0	99.5	97.5	96.3	96.1	70.0	60.0			
8.0	84.0	82.0	80.9	80.6	70.0	60.0	47.0	38.0	
9.0	72.2	70.2	69.1	68.8	70.0	60.0	47.0	38.0	32.0
10.0	62.9	60.8	59.7	59.5	61.9	60.0	47.0	38.0	32.0
11.0	55.3	53.3	52.2	51.9	54.3	55.6	47.0	38.0	32.0
12.0	49.1	47.0	46.0	45.7	48.0	49.4	47.0	38.0	32.0
14.0		37.0	35.9	35.7	37.9	39.2	39.9	38.0	32.0
16.0		28.5	27.5	27.3	29.4	30.5	31.2	31.6	31.0
18.0			21.6	21.4	23.3	24.4	25.1	25.4	25.7
20.0			17.2	17.0	18.8	19.8	20.5	20.8	21.0
22.0				13.6	15.3	16.3	16.9	17.2	17.5
24.0					12.5	13.5	14.1	14.4	14.6
26.0					10.2	11.2	11.8	12.1	12.3
28.0					8.1	9.3	9.8	10.1	10.3
30.0						7.4	8.1	8.5	8.7
32.0						5.7	6.4	6.8	7.1
34.0						4.3	4.9	5.3	5.6
36.0						3.1	3.7	4.0	4.3
38.0									3.2
危険角度 (°)	—	—	—	—	—	15	33	40	44
フック種類	150t	150t	150t	150t	83t	83t	83t	83t	83t
フック質量 (t)	1.90	1.90	1.90	1.90	1.0	1.0	1.0	1.0	1.0
巻掛本数	14	12	12	12	7	6	4	4	4

(単位 : ton)



14.4m — 55.0m

メインブーム【通常伸縮】

G3性能

カウンタウエイト 31t アウトリガ張出 7.4m (側方)

作業半径 (m)	14.4m ブーム	19.55m ブーム	23.6m ブーム	24.7m ブーム	32.0m ブーム	40.0m ブーム	45.0m ブーム	50.0m ブーム	55.0m ブーム
3.0	150.0								
3.5	150.0	120.0							
4.0	150.0	120.0	120.0	120.0					
4.5	149.3	120.0	120.0	120.0					
5.0	137.0	120.0	120.0	120.0	70.0				
6.0	117.2	115.6	114.8	114.6	70.0				
7.0	99.5	97.5	96.3	96.1	70.0	60.0			
8.0	84.0	82.0	80.9	80.6	70.0	60.0	47.0	38.0	
9.0	69.4	67.2	66.0	65.8	68.4	60.0	47.0	38.0	32.0
10.0	56.6	54.6	53.5	53.3	55.6	57.0	47.0	38.0	32.0
11.0	47.4	45.4	44.4	44.2	46.4	47.7	47.0	38.0	32.0
12.0	40.3	38.5	37.5	37.3	39.4	40.6	41.3	38.0	32.0
14.0		28.6	27.7	27.5	29.5	30.6	31.2	31.6	31.8
16.0		22.0	21.1	20.9	22.8	23.8	24.4	24.8	25.0
18.0			16.4	16.2	17.9	18.9	19.5	19.9	20.1
20.0			12.9	12.7	14.3	15.3	15.9	16.2	16.4
22.0				10.0	11.5	12.4	13.0	13.3	13.5
24.0					9.2	10.1	10.7	10.9	11.2
26.0					7.4	8.3	8.8	9.1	9.3
28.0					5.5	6.7	7.2	7.5	7.7
30.0						5.1	5.7	6.1	6.3
32.0						3.6	4.2	4.6	4.9
34.0								3.3	3.6
危険角度 (°)	—	—	—	—	—	33	41	45	50
フック種類	150t	150t	150t	150t	83t	83t	83t	83t	83t
フック質量 (t)	1.90	1.90	1.90	1.90	1.0	1.0	1.0	1.0	1.0
巻掛本数	14	12	12	12	7	6	4	4	4

(単位 : ton)

G4性能

カウンタウエイト 31t アウトリガ張出 6.4m (側方)

作業半径 (m)	14.4m ブーム	19.55m ブーム	23.6m ブーム	24.7m ブーム	32.0m ブーム	40.0m ブーム	45.0m ブーム	50.0m ブーム	55.0m ブーム
3.0	150.0								
3.5	150.0	120.0							
4.0	150.0	120.0	120.0	120.0					
4.5	149.3	120.0	120.0	120.0					
5.0	137.0	120.0	120.0	120.0	70.0				
6.0	117.2	115.6	114.8	114.6	70.0				
7.0	91.2	88.8	87.5	87.3	70.0	60.0			
8.0	69.9	67.7	66.6	66.4	68.9	60.0	47.0	38.0	
9.0	55.9	53.9	52.9	52.6	55.0	56.3	47.0	38.0	32.0
10.0	46.0	44.2	43.2	43.0	45.2	46.4	47.0	38.0	32.0
11.0	38.7	36.9	36.0	35.8	37.9	39.0	39.8	38.0	32.0
12.0	33.1	31.3	30.4	30.2	32.2	33.3	34.0	34.4	32.0
14.0		23.3	22.4	22.2	24.1	25.1	25.8	26.1	26.3
16.0		17.8	16.9	16.7	18.5	19.5	20.1	20.4	20.6
18.0			12.9	12.7	14.4	15.4	16.0	16.2	16.5
20.0			9.9	9.7	11.3	12.2	12.8	13.1	13.3
22.0				7.3	8.9	9.8	10.3	10.6	10.8
24.0					6.9	7.8	8.3	8.6	8.8
26.0					4.8	6.1	6.7	6.9	7.1
28.0					3.1	4.3	5.0	5.4	5.7
30.0							3.5	3.9	4.2
危険角度 (°)	—	—	—	—	20	43	46	51	55
フック種類	150t	150t	150t	150t	83t	83t	83t	83t	83t
フック質量 (t)	1.90	1.90	1.90	1.90	1.0	1.0	1.0	1.0	1.0
巻掛本数	14	12	12	12	7	6	4	4	4

(単位 : ton)



14.4m — 55.0m

メインブーム【通常伸縮】

H1性能

カウンタウエイト 21t アウトリガ張出 9.4m (全周)

作業半径 (m)	14.4m ブーム	19.55m ブーム	23.6m ブーム	24.7m ブーム	32.0m ブーム	40.0m ブーム	45.0m ブーム	50.0m ブーム	55.0m ブーム
3.0	150.0								
3.5	150.0	120.0							
4.0	150.0	120.0	120.0	120.0					
4.5	144.2	120.0	120.0	120.0					
5.0	132.2	120.0	120.0	120.0	70.0				
6.0	110.7	108.6	107.4	107.2	70.0				
7.0	91.1	89.0	87.9	87.6	70.0	60.0			
8.0	76.7	74.7	73.6	73.3	70.0	60.0	47.0	38.0	
9.0	65.7	63.7	62.6	62.4	64.8	60.0	47.0	38.0	32.0
10.0	57.1	55.1	54.0	53.7	56.1	57.4	47.0	38.0	32.0
11.0	50.1	48.1	47.0	46.7	49.1	50.4	47.0	38.0	32.0
12.0	44.3	42.3	41.2	41.0	43.3	44.6	45.4	38.0	32.0
14.0		33.3	32.2	32.0	34.2	35.5	36.3	36.7	32.0
16.0		26.7	25.6	25.4	27.6	28.8	29.6	30.0	30.2
18.0			20.5	20.3	22.4	23.6	24.3	24.7	24.9
20.0			16.3	16.0	17.9	19.0	19.7	20.0	20.2
22.0				12.7	14.4	15.5	16.1	16.4	16.7
24.0					11.6	12.7	13.3	13.6	13.8
26.0					9.3	10.4	11.0	11.3	11.5
28.0					7.1	8.4	9.1	9.4	9.6
30.0						6.5	7.2	7.6	7.9
32.0						4.9	5.5	5.9	6.2
34.0						3.5	4.1	4.5	4.8
36.0								3.3	3.5
危険角度 (°)	—	—	—	—	—	27	37	41	47
フック種類	150t	150t	150t	150t	83t	83t	83t	83t	83t
フック質量 (t)	1.90	1.90	1.90	1.90	1.0	1.0	1.0	1.0	1.0
巻掛本数	14	12	12	12	7	6	4	4	4

(単位 : ton)

H2性能

カウンタウエイト 21t アウトリガ張出 8.4m (側方)

作業半径 (m)	14.4m ブーム	19.55m ブーム	23.6m ブーム	24.7m ブーム	32.0m ブーム	40.0m ブーム	45.0m ブーム	50.0m ブーム	55.0m ブーム
3.0	150.0								
3.5	150.0	120.0							
4.0	150.0	120.0	120.0	120.0					
4.5	144.2	120.0	120.0	120.0					
5.0	132.2	120.0	120.0	120.0	70.0				
6.0	110.7	108.6	107.4	107.2	70.0				
7.0	91.1	89.0	87.9	87.6	70.0	60.0			
8.0	76.7	74.7	73.6	73.3	70.0	60.0	47.0	38.0	
9.0	65.7	63.7	62.6	62.4	64.8	60.0	47.0	38.0	32.0
10.0	57.1	55.1	54.0	53.7	56.1	57.4	47.0	38.0	32.0
11.0	50.1	48.1	47.0	46.7	49.1	50.4	47.0	38.0	32.0
12.0	43.6	41.4	40.3	40.0	42.4	43.8	44.6	38.0	32.0
14.0		30.3	29.3	29.0	31.2	32.5	33.2	33.6	32.0
16.0		23.0	22.0	21.8	23.8	25.0	25.7	26.0	26.3
18.0			16.8	16.6	18.5	19.6	20.3	20.7	20.9
20.0			13.0	12.8	14.6	15.7	16.3	16.6	16.9
22.0				9.7	11.6	12.6	13.2	13.5	13.8
24.0					9.0	10.2	10.8	11.1	11.3
26.0					6.6	8.0	8.7	9.0	9.3
28.0					4.7	6.0	6.7	7.1	7.4
30.0						4.3	5.0	5.4	5.7
32.0							3.5	3.9	4.2
危険角度 (°)	—	—	—	—	—	38	42	48	52
フック種類	150t	150t	150t	150t	83t	83t	83t	83t	83t
フック質量 (t)	1.90	1.90	1.90	1.90	1.0	1.0	1.0	1.0	1.0
巻掛本数	14	12	12	12	7	6	4	4	4

(単位 : ton)



14.4m — 55.0m

メインブーム【通常伸縮】

H3性能

カウンタウエイト 21t アウトリガ張出 7.4m (側方)

作業半径 (m)	14.4m ブーム	19.55m ブーム	23.6m ブーム	24.7m ブーム	32.0m ブーム	40.0m ブーム	45.0m ブーム	50.0m ブーム	55.0m ブーム
3.0	150.0								
3.5	150.0	120.0							
4.0	150.0	120.0	120.0	120.0					
4.5	144.2	120.0	120.0	120.0					
5.0	132.2	120.0	120.0	120.0	70.0				
6.0	110.7	108.6	107.4	107.2	70.0				
7.0	91.1	89.0	87.9	87.6	70.0	60.0			
8.0	74.6	72.3	71.0	70.7	70.0	60.0	47.0	38.0	
9.0	58.4	56.3	55.1	54.9	57.4	58.9	47.0	38.0	32.0
10.0	47.4	45.4	44.3	44.1	46.4	47.8	47.0	38.0	32.0
11.0	39.4	37.5	36.5	36.2	38.5	39.7	40.5	38.0	32.0
12.0	33.4	31.5	30.5	30.3	32.4	33.6	34.3	34.7	32.0
14.0		23.0	22.1	21.9	23.8	24.9	25.6	25.9	26.2
16.0		17.3	16.4	16.2	18.0	19.1	19.7	20.0	20.3
18.0			12.4	12.2	13.9	14.9	15.5	15.8	16.0
20.0			9.3	9.1	10.8	11.7	12.3	12.6	12.8
22.0				6.5	8.3	9.3	9.8	10.1	10.3
24.0					6.2	7.3	7.8	8.1	8.3
26.0					4.1	5.4	6.1	6.4	6.7
28.0						3.7	4.4	4.8	5.1
30.0								3.2	3.5
危険角度 (°)	—	—	—	—	30	43	49	51	55
フック種類	150t	150t	150t	150t	83t	83t	83t	83t	83t
フック質量 (t)	1.90	1.90	1.90	1.90	1.0	1.0	1.0	1.0	1.0
巻掛本数	14	12	12	12	7	6	4	4	4

(単位 : ton)

H4性能

カウンタウエイト 21t アウトリガ張出 6.4m (側方)

作業半径 (m)	14.4m ブーム	19.55m ブーム	23.6m ブーム	24.7m ブーム	32.0m ブーム	40.0m ブーム	45.0m ブーム	50.0m ブーム	55.0m ブーム
3.0	150.0								
3.5	150.0	120.0							
4.0	150.0	120.0	120.0	120.0					
4.5	144.2	120.0	120.0	120.0					
5.0	132.2	120.0	120.0	120.0	70.0				
6.0	108.3	105.5	104.0	102.5	70.0				
7.0	76.8	74.5	73.2	72.9	70.0	60.0			
8.0	58.5	56.4	55.2	55.0	57.5	57.4	47.0	38.0	
9.0	46.5	44.5	43.5	43.2	45.6	46.9	47.0	38.0	32.0
10.0	38.0	36.2	35.2	34.9	37.1	38.4	39.1	38.0	32.0
11.0	31.8	29.9	29.0	28.8	30.8	32.0	32.7	33.1	32.0
12.0	26.9	25.1	24.2	24.0	26.0	27.1	27.8	28.2	28.4
14.0		18.2	17.3	17.1	19.0	20.1	20.7	21.0	21.3
16.0		13.5	12.6	12.5	14.2	15.2	15.8	16.1	16.4
18.0			9.2	9.0	10.7	11.7	12.3	12.6	12.8
20.0			6.4	6.1	8.0	9.0	9.5	9.8	10.0
22.0					5.7	6.9	7.4	7.7	7.9
24.0					3.5	4.8	5.5	5.9	6.2
26.0						3.0	3.7	4.1	4.4
危険角度 (°)	—	—	—	25	38	47	53	57	60
フック種類	150t	150t	150t	150t	83t	83t	83t	83t	83t
フック質量 (t)	1.90	1.90	1.90	1.90	1.0	1.0	1.0	1.0	1.0
巻掛本数	14	12	12	12	7	6	4	4	4

(単位 : ton)



14.4m — 55.0m

メインブーム【通常伸縮】

H5性能

カウンタウエイト 21t アウトリガ張出 5.4m (側方)

作業半径 (m)	14.4m ブーム	19.55m ブーム	23.6m ブーム	24.7m ブーム	32.0m ブーム	40.0m ブーム	45.0m ブーム	50.0m ブーム	55.0m ブーム
3.0	150.0								
3.5	150.0	120.0							
4.0	150.0	120.0	120.0	120.0					
4.5	144.2	120.0	120.0	120.0					
5.0	111.8	109.2	107.6	105.0	70.0				
6.0	74.8	72.6	71.4	71.1	70.0				
7.0	54.9	53.0	51.9	51.7	54.0	54.9			
8.0	42.6	40.8	39.8	39.6	41.7	43.0	43.7	38.0	
9.0	34.2	32.5	31.5	31.3	33.4	34.5	35.2	35.5	32.0
10.0	28.1	26.4	25.6	25.4	27.3	28.3	29.0	29.3	29.6
11.0	23.4	21.9	21.0	20.8	22.6	23.7	24.3	24.6	24.9
12.0	19.8	18.3	17.4	17.3	19.0	20.0	20.6	20.9	21.2
14.0		13.0	12.2	12.0	13.7	14.7	15.2	15.5	15.7
16.0		9.4	8.6	8.4	10.0	10.9	11.5	11.7	11.9
18.0			5.9	5.7	7.2	8.1	8.7	8.9	9.1
20.0					5.1	6.0	6.5	6.8	7.0
22.0						4.1	4.8	5.1	5.3
危険角度 (°)	—	—	35	39	49	55	59	62	65
フック種類	150t	150t	150t	150t	83t	83t	83t	83t	83t
フック質量 (t)	1.90	1.90	1.90	1.90	1.0	1.0	1.0	1.0	1.0
巻掛本数	14	12	12	12	7	6	4	4	4

(単位 : ton)



14.4m — 55.0m

メインブーム【通常伸縮】

J1性能

カウンタウエイト 11t アウトリガ張出 9.4m (全周)

作業半径 (m)	14.4m ブーム	19.55m ブーム	23.6m ブーム	24.7m ブーム	32.0m ブーム	40.0m ブーム	45.0m ブーム	50.0m ブーム	55.0m ブーム
3.0	150.0								
3.5	150.0	120.0							
4.0	150.0	120.0	120.0	120.0					
4.5	139.0	120.0	120.0	120.0					
5.0	126.9	120.0	120.0	120.0	70.0				
6.0	100.8	98.7	97.5	97.3	70.0				
7.0	82.7	80.6	79.5	79.2	70.0	60.0			
8.0	69.4	67.4	66.3	66.0	68.5	60.0	47.0	38.0	
9.0	59.3	57.3	56.2	55.9	58.4	59.7	47.0	38.0	32.0
10.0	51.3	49.3	48.2	48.0	50.3	51.7	47.0	38.0	32.0
11.0	44.9	42.8	41.8	41.5	43.9	45.2	46.0	38.0	32.0
12.0	39.6	37.5	36.5	36.2	38.5	39.8	40.6	38.0	32.0
14.0		29.1	28.0	27.7	30.0	31.4	32.2	32.6	32.0
16.0		21.7	20.6	20.4	22.5	23.7	24.5	24.8	25.1
18.0			15.5	15.3	17.2	18.4	19.1	19.4	19.7
20.0			11.7	11.5	13.4	14.5	15.1	15.5	15.7
22.0				8.2	10.4	11.5	12.1	12.4	12.6
24.0					7.7	9.1	9.7	10.0	10.2
26.0					5.3	6.7	7.5	7.9	8.2
28.0					3.5	4.8	5.5	5.9	6.2
30.0						3.1	3.8	4.2	4.6
32.0									3.1
危険角度 (°)	—	—	—	—	10	38	45	50	52
フック種類	150t	150t	150t	150t	83t	83t	83t	83t	83t
フック質量 (t)	1.90	1.90	1.90	1.90	1.0	1.0	1.0	1.0	1.0
巻掛本数	14	12	12	12	7	6	4	4	4

(単位 : ton)

J2性能

カウンタウエイト 11t アウトリガ張出 8.4m (側方)

作業半径 (m)	14.4m ブーム	19.55m ブーム	23.6m ブーム	24.7m ブーム	32.0m ブーム	40.0m ブーム	45.0m ブーム	50.0m ブーム	55.0m ブーム
3.0	150.0								
3.5	150.0	120.0							
4.0	150.0	120.0	120.0	120.0					
4.5	139.0	120.0	120.0	120.0					
5.0	126.9	120.0	120.0	120.0	70.0				
6.0	100.8	98.7	97.5	97.3	70.0				
7.0	82.7	80.6	79.5	79.2	70.0	60.0			
8.0	69.4	67.4	66.3	66.0	68.5	60.0	47.0	38.0	
9.0	59.3	57.3	56.2	55.9	58.4	59.3	47.0	38.0	32.0
10.0	51.3	48.9	47.6	47.4	50.1	49.7	47.0	38.0	32.0
11.0	42.0	39.8	38.6	38.3	40.9	42.3	41.6	38.0	32.0
12.0	35.1	33.0	31.9	31.6	34.0	35.4	36.0	35.1	32.0
14.0		23.6	22.5	22.3	24.5	25.8	26.5	26.9	26.4
16.0		17.4	16.4	16.2	18.2	19.4	20.1	20.5	20.7
18.0			12.1	11.9	13.8	14.9	15.6	15.9	16.1
20.0			8.5	8.2	10.4	11.5	12.2	12.5	12.7
22.0				5.2	7.5	8.9	9.5	9.8	10.1
24.0					5.0	6.4	7.1	7.6	7.9
26.0					3.0	4.3	5.0	5.5	5.8
28.0							3.3	3.7	4.0
危険角度 (°)	—	—	—	—	30	47	50	54	58
フック種類	150t	150t	150t	150t	83t	83t	83t	83t	83t
フック質量 (t)	1.90	1.90	1.90	1.90	1.0	1.0	1.0	1.0	1.0
巻掛本数	14	12	12	12	7	6	4	4	4

(単位 : ton)



14.4m — 55.0m

メインブーム【通常伸縮】

J3性能

カウンタウエイト 11t アウトリガ張出 7.4m (側方)

作業半径 (m)	14.4m ブーム	19.55m ブーム	23.6m ブーム	24.7m ブーム	32.0m ブーム	40.0m ブーム	45.0m ブーム	50.0m ブーム	55.0m ブーム
3.0	150.0								
3.5	150.0	120.0							
4.0	150.0	120.0	120.0	120.0					
4.5	139.0	120.0	120.0	120.0					
5.0	126.9	120.0	120.0	120.0	70.0				
6.0	100.8	98.7	97.5	97.3	70.0				
7.0	82.7	80.3	78.9	78.5	70.0	60.0			
8.0	61.1	58.8	57.5	57.2	60.0	57.7	47.0	38.0	
9.0	47.5	45.3	44.2	43.9	46.5	47.7	46.5	38.0	32.0
10.0	38.2	36.2	35.1	34.9	37.2	38.6	39.3	38.0	32.0
11.0	31.5	29.5	28.5	28.3	30.5	31.8	32.5	32.8	31.9
12.0	26.4	24.5	23.5	23.3	25.4	26.6	27.3	27.7	27.7
14.0		17.4	16.4	16.2	18.2	19.3	20.0	20.3	20.6
16.0		12.6	11.7	11.5	13.3	14.4	15.0	15.3	15.6
18.0			8.3	8.1	9.8	10.8	11.4	11.7	12.0
20.0					7.2	8.2	8.7	9.0	9.3
22.0					4.6	6.0	6.6	6.9	7.1
24.0						3.8	4.5	5.0	5.3
危険角度 (°)	—	—	35	39	43	51	56	58	62
フック種類	150t	150t	150t	150t	83t	83t	83t	83t	83t
フック質量 (t)	1.90	1.90	1.90	1.90	1.0	1.0	1.0	1.0	1.0
巻掛本数	14	12	12	12	7	6	4	4	4

(単位 : ton)

J4性能

カウンタウエイト 11t アウトリガ張出 6.4m (側方)

作業半径 (m)	14.4m ブーム	19.55m ブーム	23.6m ブーム	24.7m ブーム	32.0m ブーム	40.0m ブーム	45.0m ブーム	50.0m ブーム	55.0m ブーム
3.0	150.0								
3.5	150.0	120.0							
4.0	150.0	120.0	120.0	120.0					
4.5	139.0	120.0	120.0	120.0					
5.0	126.9	120.0	118.3	115.0	70.0				
6.0	88.8	86.0	84.1	82.1	70.0				
7.0	62.4	60.1	58.8	58.5	59.6	55.8			
8.0	47.1	45.0	43.8	43.6	46.1	45.4	44.1	38.0	
9.0	37.1	35.1	34.0	33.8	36.1	37.4	36.8	35.6	32.0
10.0	30.0	28.1	27.1	26.9	29.1	30.3	31.1	30.2	29.3
11.0	24.7	22.9	22.0	21.8	23.8	25.0	25.7	25.8	25.2
12.0	20.7	18.9	18.0	17.8	19.8	20.9	21.6	21.9	21.7
14.0		13.2	12.3	12.1	13.9	15.0	15.6	16.0	16.2
16.0		9.2	8.4	8.2	9.9	10.9	11.6	11.9	12.1
18.0					7.0	8.0	8.6	8.9	9.1
20.0					4.1	5.5	6.3	6.6	6.8
22.0						3.2			
危険角度 (°)	—	—	35	39	43	51	56	58	62
フック種類	150t	150t	150t	150t	83t	83t	83t	83t	83t
フック質量 (t)	1.90	1.90	1.90	1.90	1.0	1.0	1.0	1.0	1.0
巻掛本数	14	12	12	12	7	6	4	4	4

(単位 : ton)

J5性能

カウンタウエイト 11t アウトリガ張出 5.4m (側方)

作業半径 (m)	14.4m ブーム	19.55m ブーム	23.6m ブーム	24.7m ブーム	32.0m ブーム	40.0m ブーム	45.0m ブーム	50.0m ブーム	55.0m ブーム
3.0	150.0								
3.5	150.0	120.0							
4.0	150.0	120.0	120.0	120.0					
4.5	119.1	114.6	102.7	99.8					
5.0	90.9	88.3	85.4	83.2	70.0				
6.0	60.2	58.0	56.8	56.5	57.8				
7.0	43.7	41.8	40.7	40.5	42.8	42.7			
8.0	33.5	31.7	30.7	30.5	32.7	33.9	34.0	32.8	
9.0	26.5	24.8	23.9	23.7	25.7	26.9	27.6	27.4	26.5
10.0	21.5	19.8	19.0	18.8	20.7	21.8	22.4	22.7	22.4
11.0	17.6	16.1	15.2	15.0	16.8	17.9	18.5	18.8	19.0
12.0	14.7	13.1	12.3	12.1	13.8	14.8	15.5	15.8	16.0
14.0		8.7	8.0	7.8	9.4	10.4	11.0	11.3	11.5
16.0		5.7			6.4	7.3	7.8	8.1	8.3
18.0					3.6	5.0	5.5	5.8	
危険角度 (°)	—	—	50	52	53	61	65	68	71
フック種類	150t	150t	150t	150t	83t	83t	83t	83t	83t
フック質量 (t)	1.90	1.90	1.90	1.90	1.0	1.0	1.0	1.0	1.0
巻掛本数	14	12	12	12	7	6	4	4	4

(単位 : ton)



14.4m — 55.0m

メインブーム【通常伸縮】

K1性能

カウンタウエイト0t アウトリガ張出9.4m(全周)

作業半径 (m)	14.4m ブーム	19.55m ブーム	23.6m ブーム	24.7m ブーム	32.0m ブーム	40.0m ブーム	45.0m ブーム	50.0m ブーム	55.0m ブーム
3.0	150.0								
3.5	150.0	120.0							
4.0	146.8	120.0	120.0	120.0					
4.5	130.4	120.0	120.0	120.0					
5.0	114.1	111.9	110.8	110.5	70.0				
6.0	90.2	88.2	87.1	86.8	70.0				
7.0	73.8	71.7	70.6	70.4	70.0	60.0			
8.0	61.7	59.7	58.6	58.4	60.8	60.0	47.0	38.0	
9.0	52.5	50.5	49.4	49.2	51.6	52.9	47.0	38.0	32.0
10.0	45.2	43.2	42.2	41.9	44.3	45.6	45.3	38.0	32.0
11.0	39.3	37.3	36.0	35.7	38.4	38.9	38.2	37.1	32.0
12.0	32.7	30.4	29.2	28.9	31.5	33.0	32.7	31.8	31.0
14.0		21.0	19.9	19.7	22.0	23.3	24.1	23.9	23.4
16.0		15.1	14.0	13.8	15.9	17.1	17.9	18.2	18.0
18.0			9.7	9.4	11.6	12.8	13.5	13.8	13.9
20.0			6.0	5.7	8.2	9.6	10.2	10.6	10.8
22.0					5.3	6.7	7.5	8.0	8.2
24.0						4.3	5.1	5.6	5.9
26.0							3.2	3.6	3.9
危険角度(°)	—	—	—	28	42	50	52	57	62
フック種類	150t	150t	150t	150t	83t	83t	83t	83t	83t
フック質量(t)	1.90	1.90	1.90	1.90	1.0	1.0	1.0	1.0	1.0
巻掛本数	14	12	12	12	7	6	4	4	4

(単位: ton)

K2性能

カウンタウエイト0t アウトリガ張出8.4m(側方)

作業半径 (m)	14.4m ブーム	19.55m ブーム	23.6m ブーム	24.7m ブーム	32.0m ブーム	40.0m ブーム	45.0m ブーム	50.0m ブーム	55.0m ブーム
3.0	150.0								
3.5	150.0	120.0							
4.0	146.8	120.0	120.0	120.0					
4.5	130.4	120.0	120.0	120.0					
5.0	114.1	111.9	110.8	110.5	70.0				
6.0	90.2	88.2	87.1	86.8	70.0				
7.0	73.8	71.7	70.6	70.4	70.0	60.0			
8.0	61.7	59.7	58.6	58.4	58.6	55.1	47.0	38.0	
9.0	49.6	47.1	45.7	45.4	46.8	44.7	43.6	38.0	32.0
10.0	39.0	36.7	35.4	35.1	37.9	37.0	36.3	35.2	32.0
11.0	31.6	29.3	28.2	27.9	30.5	31.0	30.6	29.8	28.9
12.0	26.1	23.9	22.8	22.5	24.9	26.2	26.1	25.5	24.8
14.0		16.4	15.3	15.1	17.3	18.5	19.2	18.9	18.5
16.0		11.4	10.4	10.1	12.2	13.4	14.1	14.2	14.0
18.0			6.1	5.8	8.4	9.8	10.4	10.6	10.5
20.0					5.1	6.6	7.4	7.8	7.8
22.0						4.0	4.8	5.3	5.6
危険角度(°)	—	—	34	38	48	54	59	62	66
フック種類	150t	150t	150t	150t	83t	83t	83t	83t	83t
フック質量(t)	1.90	1.90	1.90	1.90	1.0	1.0	1.0	1.0	1.0
巻掛本数	14	12	12	12	7	6	4	4	4

(単位: ton)

K3性能

カウンタウエイト0t アウトリガ張出7.4m(側方)

作業半径 (m)	14.4m ブーム	19.55m ブーム	23.6m ブーム	24.7m ブーム	32.0m ブーム	40.0m ブーム	45.0m ブーム	50.0m ブーム	55.0m ブーム
3.0	150.0								
3.5	150.0	120.0							
4.0	146.8	120.0	120.0	120.0					
4.5	130.4	120.0	120.0	120.0					
5.0	114.1	111.9	110.8	110.5	70.0				
6.0	90.2	88.2	85.1	82.8	70.0				
7.0	64.1	61.4	59.9	59.6	57.8	53.8			
8.0	46.6	44.2	43.0	42.7	45.2	42.8	41.6	38.0	
9.0	35.7	33.6	32.4	32.1	34.7	34.8	34.1	33.0	31.8
10.0	28.3	26.3	25.2	24.9	27.3	28.6	28.4	27.6	26.7
11.0	22.9	21.0	20.0	19.7	21.9	23.2	23.8	23.2	22.6
12.0	18.9	17.0	16.0	15.8	17.9	19.1	19.8	19.7	19.2
14.0		11.3	10.4	10.2	12.1	13.2	13.9	14.2	14.0
16.0		7.5	6.3	6.1	8.2	9.3	9.9	10.2	10.2
18.0					5.0	6.5	7.1	7.3	7.3
20.0							4.5		
危険角度(°)	—	—	43	46	53	60	63	67	70
フック種類	150t	150t	150t	150t	83t	83t	83t	83t	83t
フック質量(t)	1.90	1.90	1.90	1.90	1.0	1.0	1.0	1.0	1.0
巻掛本数	14	12	12	12	7	6	4	4	4

(単位: ton)



14.4m — 55.0m

メインブーム【通常伸縮】

K4性能

カウンタウエイト 0t アウトリガ張出 6.4m (側方)

作業半径 (m)	14.4m ブーム	19.55m ブーム	23.6m ブーム	24.7m ブーム	32.0m ブーム	40.0m ブーム	45.0m ブーム	50.0m ブーム	55.0m ブーム
3.0	150.0								
3.5	150.0	120.0							
4.0	146.8	120.0	120.0	120.0					
4.5	130.4	120.0	110.0	106.5					
5.0	111.7	99.7	88.6	86.0	70.0				
6.0	67.8	65.0	61.8	60.1	56.9				
7.0	47.0	44.6	43.3	43.1	43.3	40.7			
8.0	34.9	32.7	31.6	31.3	33.9	32.4	31.7	30.5	
9.0	26.9	25.0	23.9	23.7	26.0	26.2	25.9	25.0	24.2
10.0	21.3	19.5	18.5	18.2	20.4	21.5	21.3	20.8	20.1
11.0	17.2	15.4	14.4	14.2	16.3	17.5	17.7	17.3	16.8
12.0	14.0	12.3	11.3	11.1	13.1	14.2	14.7	14.4	14.1
14.0		7.7	6.6	6.4	8.5	9.6	10.1	10.0	9.8
16.0					4.9	6.3	6.7	6.7	
危険角度 (°)	—	35	50	52	57	65	68	71	74
フック種類	150t	150t	150t	150t	83t	83t	83t	83t	83t
フック質量 (t)	1.90	1.90	1.90	1.90	1.0	1.0	1.0	1.0	1.0
巻掛本数	14	12	12	12	7	6	4	4	4

(単位 : ton)

K5性能

カウンタウエイト 0t アウトリガ張出 5.4m (側方)

作業半径 (m)	14.4m ブーム	19.55m ブーム	23.6m ブーム	24.7m ブーム	32.0m ブーム	40.0m ブーム	45.0m ブーム	50.0m ブーム	55.0m ブーム
3.0	150.0								
3.5	150.0	120.0							
4.0	129.2	107.0	93.6	90.5					
4.5	90.4	84.7	74.9	72.6					
5.0	68.4	65.8	61.6	59.8	55.7				
6.0	44.5	42.3	41.1	40.8	41.0				
7.0	31.7	29.8	28.7	28.5	30.8	29.7			
8.0	23.7	21.9	21.0	20.7	22.9	23.4	23.1	22.2	
9.0	18.3	16.6	15.7	15.5	17.5	18.6	18.6	18.0	17.4
10.0	14.4	12.8	11.9	11.7	13.6	14.7	15.0	14.7	14.2
11.0	11.4	9.8	9.0	8.8	10.6	11.7	12.2	11.9	11.6
12.0	9.1	7.5	6.7	6.5	8.3	9.3	9.8	9.6	9.4
危険角度 (°)	—	47	56	58	64	70	73	76	77
フック種類	150t	150t	150t	150t	83t	83t	83t	83t	83t
フック質量 (t)	1.90	1.90	1.90	1.90	1.0	1.0	1.0	1.0	1.0
巻掛本数	14	12	12	12	7	6	4	4	4

(単位 : ton)



メインブーム【特殊伸縮】作業範囲図

- Ⓐ 14.4 m ブーム
- Ⓑ 19.55 m ブーム
- Ⓒ 24.7 m ブーム
- Ⓓ 32.0 m ブーム
- Ⓔ 40.0 m ブーム
- Ⓕ 44.7 m ブーム
- Ⓖ 14.4 m ブーム + ルースターシーブ
- Ⓗ 19.55 m ブーム + ルースターシーブ
- Ⓘ 24.7 m ブーム + ルースターシーブ
- Ⓙ 32.0 m ブーム + ルースターシーブ
- Ⓚ 40.0 m ブーム + ルースターシーブ
- Ⓛ 44.7 m ブーム + ルースターシーブ

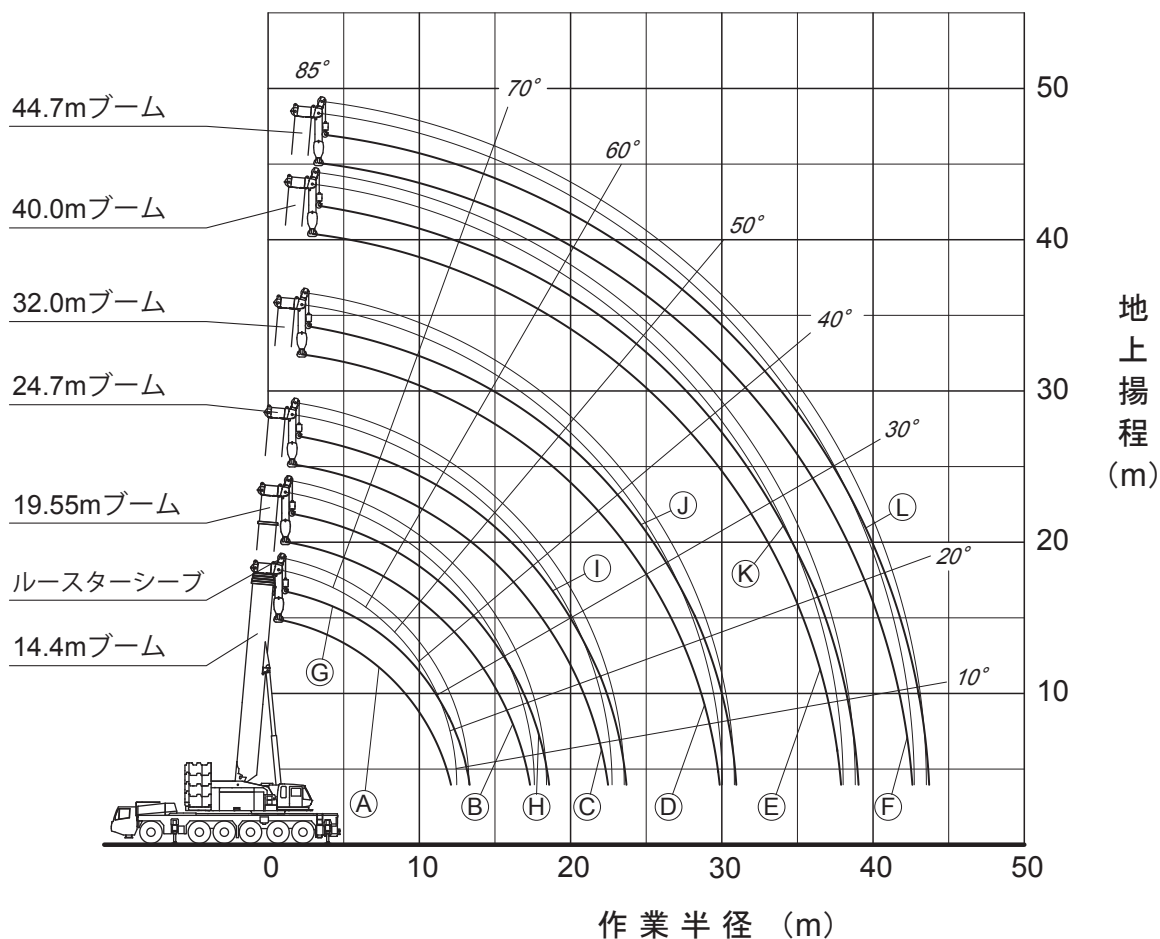

注1. 本図は、ブームのたわみを含んでいません。
 2. TA1性能時のものを示してします。



14.4m — 44.7m

メインブーム【特殊伸縮】

TA1性能

カウンタウエイト 105t アウトリガ張出 9.4m (全周)

作業半径 (m)	14.4m ブーム	19.55m ブーム	24.7m ブーム	32.0m ブーム	40.0m ブーム	44.7m ブーム
3.0	150.0					
3.5	150.0	70.0				
4.0	150.0	70.0	70.0			
4.5	150.0	70.0	70.0			
5.0	150.0	70.0	70.0	60.0		
6.0	144.9	70.0	70.0	60.0		
7.0	126.4	70.0	70.0	60.0	35.0	
8.0	111.8	70.0	70.0	60.0	35.0	32.0
9.0	99.8	70.0	70.0	60.0	35.0	32.0
10.0	89.9	70.0	70.0	60.0	35.0	32.0
11.0	81.6	70.0	70.0	60.0	35.0	32.0
12.0	72.4	70.0	70.0	60.0	35.0	32.0
14.0		64.5	65.1	53.8	35.0	32.0
16.0		55.5	56.2	47.4	35.0	28.7
18.0			49.1	42.1	32.1	25.3
20.0			43.3	37.7	28.7	22.5
22.0			35.3	34.0	25.7	20.2
24.0				30.9	23.2	18.2
26.0				28.3	21.0	16.5
28.0				26.0	19.1	15.0
30.0					17.5	13.7
32.0					16.1	12.6
34.0					14.8	11.6
36.0					13.6	10.7
38.0						9.9
40.0						9.2
42.0						8.6
危険角度 (°)	—	—	—	—	—	—
フック種類	150t	83t	83t	83t	83t	83t
フック質量 (t)	1.90	1.0	1.0	1.0	1.0	1.0
巻掛本数	14	7	7	6	4	4

(単位 : ton)

TA2性能

カウンタウエイト 105t アウトリガ張出 8.4m (側方)

作業半径 (m)	14.4m ブーム	19.55m ブーム	24.7m ブーム	32.0m ブーム	40.0m ブーム	44.7m ブーム
3.0	150.0					
3.5	150.0	70.0				
4.0	150.0	70.0	70.0			
4.5	150.0	70.0	70.0			
5.0	150.0	70.0	70.0	60.0		
6.0	144.9	70.0	70.0	60.0		
7.0	126.4	70.0	70.0	60.0	35.0	
8.0	111.8	70.0	70.0	60.0	35.0	32.0
9.0	99.8	70.0	70.0	60.0	35.0	32.0
10.0	89.9	70.0	70.0	60.0	35.0	32.0
11.0	81.6	70.0	70.0	60.0	35.0	32.0
12.0	72.4	70.0	70.0	60.0	35.0	32.0
14.0		64.5	65.1	53.8	35.0	32.0
16.0		55.5	56.2	47.4	35.0	28.7
18.0			49.1	42.1	32.1	25.3
20.0			43.3	37.7	28.7	22.5
22.0			35.3	34.0	25.7	20.2
24.0				30.9	23.2	18.2
26.0				28.3	21.0	16.5
28.0				26.0	19.1	15.0
30.0					17.5	13.7
32.0					16.1	12.6
34.0					14.8	11.6
36.0					13.6	10.7
38.0						9.9
40.0						9.2
42.0						8.6
危険角度 (°)	—	—	—	—	—	—
フック種類	150t	83t	83t	83t	83t	83t
フック質量 (t)	1.90	1.0	1.0	1.0	1.0	1.0
巻掛本数	14	7	7	6	4	4

(単位 : ton)



14.4m — 44.7m

メインブーム【特殊伸縮】

TB1性能

カウンタウエイト 93t アウトリガ張出 9.4m (全周)

作業半径 (m)	14.4m ブーム	19.55m ブーム	24.7m ブーム	32.0m ブーム	40.0m ブーム	44.7m ブーム
3.0	150.0					
3.5	150.0	70.0				
4.0	150.0	70.0	70.0			
4.5	150.0	70.0	70.0			
5.0	150.0	70.0	70.0	60.0		
6.0	140.6	70.0	70.0	60.0		
7.0	122.6	70.0	70.0	60.0	35.0	
8.0	108.3	70.0	70.0	60.0	35.0	32.0
9.0	96.7	70.0	70.0	60.0	35.0	32.0
10.0	87.1	70.0	70.0	60.0	35.0	32.0
11.0	79.0	70.0	70.0	60.0	35.0	32.0
12.0	72.1	70.0	70.0	60.0	35.0	32.0
14.0		62.3	63.0	53.8	35.0	32.0
16.0		53.6	54.3	47.4	35.0	28.7
18.0			47.4	42.1	32.1	25.3
20.0			41.3	37.7	28.7	22.5
22.0			35.3	34.0	25.7	20.2
24.0				30.9	23.2	18.2
26.0				28.3	21.0	16.5
28.0				25.9	19.1	15.0
30.0					17.5	13.7
32.0					16.1	12.6
34.0					14.8	11.6
36.0					13.6	10.7
38.0						9.9
40.0						9.2
42.0						8.6
危険角度 (°)	—	—	—	—	—	—
フック種類	150t	83t	83t	83t	83t	83t
フック質量 (t)	1.90	1.0	1.0	1.0	1.0	1.0
巻掛本数	14	7	7	6	4	4

(単位 : ton)

TB2性能

カウンタウエイト 93t アウトリガ張出 8.4m (側方)

作業半径 (m)	14.4m ブーム	19.55m ブーム	24.7m ブーム	32.0m ブーム	40.0m ブーム	44.7m ブーム
3.0	150.0					
3.5	150.0	70.0				
4.0	150.0	70.0	70.0			
4.5	150.0	70.0	70.0			
5.0	150.0	70.0	70.0	60.0		
6.0	140.6	70.0	70.0	60.0		
7.0	122.6	70.0	70.0	60.0	35.0	
8.0	108.3	70.0	70.0	60.0	35.0	32.0
9.0	96.7	70.0	70.0	60.0	35.0	32.0
10.0	87.1	70.0	70.0	60.0	35.0	32.0
11.0	79.0	70.0	70.0	60.0	35.0	32.0
12.0	72.1	70.0	70.0	60.0	35.0	32.0
14.0		62.3	63.0	53.8	35.0	32.0
16.0		53.6	54.3	47.4	35.0	28.7
18.0			47.4	42.1	32.1	25.3
20.0			41.3	37.7	28.7	22.5
22.0			35.3	34.0	25.7	20.2
24.0				30.9	23.2	18.2
26.0				28.3	21.0	16.5
28.0				25.9	19.1	15.0
30.0					17.5	13.7
32.0					16.1	12.6
34.0					14.8	11.6
36.0					13.6	10.7
38.0						9.9
40.0						9.2
42.0						8.6
危険角度 (°)	—	—	—	—	—	—
フック種類	150t	83t	83t	83t	83t	83t
フック質量 (t)	1.90	1.0	1.0	1.0	1.0	1.0
巻掛本数	14	7	7	6	4	4

(単位 : ton)



14.4m — 44.7m

メインブーム【特殊伸縮】

TC1性能

カウンタウエイト 81t アウトリガ張出 9.4m (全周)

作業半径 (m)	14.4m ブーム	19.55m ブーム	24.7m ブーム	32.0m ブーム	40.0m ブーム	44.7m ブーム
3.0	150.0					
3.5	150.0	70.0				
4.0	150.0	70.0	70.0			
4.5	150.0	70.0	70.0			
5.0	150.0	70.0	70.0	60.0		
6.0	136.3	70.0	70.0	60.0		
7.0	118.8	70.0	70.0	60.0	35.0	
8.0	104.9	70.0	70.0	60.0	35.0	32.0
9.0	93.6	70.0	70.0	60.0	35.0	32.0
10.0	84.2	70.0	70.0	60.0	35.0	32.0
11.0	76.4	70.0	70.0	60.0	35.0	32.0
12.0	69.6	70.0	70.0	60.0	35.0	32.0
14.0		60.2	60.8	53.8	35.0	32.0
16.0		50.8	51.6	47.4	35.0	28.7
18.0			44.1	42.1	32.1	25.3
20.0			38.2	37.7	28.7	22.5
22.0			33.4	33.9	25.7	20.2
24.0				29.9	23.2	18.2
26.0				26.6	21.0	16.5
28.0				23.7	19.1	15.0
30.0					17.5	13.7
32.0					16.1	12.6
34.0					14.8	11.6
36.0					13.6	10.7
38.0						9.9
40.0						9.2
42.0						8.6
危険角度 (°)	—	—	—	—	—	—
フック種類	150t	83t	83t	83t	83t	83t
フック質量 (t)	1.90	1.0	1.0	1.0	1.0	1.0
巻掛本数	14	7	7	6	4	4

(単位 : ton)

TC2性能

カウンタウエイト 81t アウトリガ張出 8.4m (側方)

作業半径 (m)	14.4m ブーム	19.55m ブーム	24.7m ブーム	32.0m ブーム	40.0m ブーム	44.7m ブーム
3.0	150.0					
3.5	150.0	70.0				
4.0	150.0	70.0	70.0			
4.5	150.0	70.0	70.0			
5.0	150.0	70.0	70.0	60.0		
6.0	136.3	70.0	70.0	60.0		
7.0	118.8	70.0	70.0	60.0	35.0	
8.0	104.9	70.0	70.0	60.0	35.0	32.0
9.0	93.6	70.0	70.0	60.0	35.0	32.0
10.0	84.2	70.0	70.0	60.0	35.0	32.0
11.0	76.4	70.0	70.0	60.0	35.0	32.0
12.0	69.6	70.0	70.0	60.0	35.0	32.0
14.0		60.2	60.8	53.8	35.0	32.0
16.0		50.8	51.6	47.4	35.0	28.7
18.0			44.1	42.1	32.1	25.3
20.0			38.2	37.7	28.7	22.5
22.0			33.4	33.9	25.7	20.2
24.0				29.9	23.2	18.2
26.0				26.6	21.0	16.5
28.0				23.7	19.1	15.0
30.0					17.5	13.7
32.0					16.1	12.6
34.0					14.8	11.6
36.0					13.6	10.7
38.0						9.9
40.0						9.2
42.0						8.6
危険角度 (°)	—	—	—	—	—	—
フック種類	150t	83t	83t	83t	83t	83t
フック質量 (t)	1.90	1.0	1.0	1.0	1.0	1.0
巻掛本数	14	7	7	6	4	4

(単位 : ton)



14.4m — 44.7m

メインブーム【特殊伸縮】

TD1性能

カウンタウエイト 69t アウトリガ張出 9.4m (全周)

作業半径 (m)	14.4m ブーム	19.55m ブーム	24.7m ブーム	32.0m ブーム	40.0m ブーム	44.7m ブーム
3.0	150.0					
3.5	150.0	70.0				
4.0	150.0	70.0	70.0			
4.5	150.0	70.0	70.0			
5.0	150.0	70.0	70.0	60.0		
6.0	132.0	70.0	70.0	60.0		
7.0	115.0	70.0	70.0	60.0	35.0	
8.0	101.5	70.0	70.0	60.0	35.0	32.0
9.0	90.5	70.0	70.0	60.0	35.0	32.0
10.0	81.4	70.0	70.0	60.0	35.0	32.0
11.0	73.7	70.0	70.0	60.0	35.0	32.0
12.0	66.6	68.3	69.2	60.0	35.0	32.0
14.0		56.0	56.8	53.8	35.0	32.0
16.0		46.9	47.7	47.4	35.0	28.7
18.0			40.6	41.3	32.1	25.3
20.0			35.1	35.7	28.7	22.5
22.0			30.6	31.1	25.7	20.2
24.0				27.4	23.2	18.2
26.0				24.2	21.0	16.5
28.0				21.6	19.1	15.0
30.0					17.5	13.7
32.0					16.1	12.6
34.0					14.8	11.6
36.0					13.6	10.7
38.0						9.9
40.0						9.2
42.0						8.6
危険角度 (°)	—	—	—	—	—	—
フック種類	150t	83t	83t	83t	83t	83t
フック質量 (t)	1.90	1.0	1.0	1.0	1.0	1.0
巻掛本数	14	7	7	6	4	4

(単位 : ton)

TD2性能

カウンタウエイト 69t アウトリガ張出 8.4m (側方)

作業半径 (m)	14.4m ブーム	19.55m ブーム	24.7m ブーム	32.0m ブーム	40.0m ブーム	44.7m ブーム
3.0	150.0					
3.5	150.0	70.0				
4.0	150.0	70.0	70.0			
4.5	150.0	70.0	70.0			
5.0	150.0	70.0	70.0	60.0		
6.0	132.0	70.0	70.0	60.0		
7.0	115.0	70.0	70.0	60.0	35.0	
8.0	101.5	70.0	70.0	60.0	35.0	32.0
9.0	90.5	70.0	70.0	60.0	35.0	32.0
10.0	81.4	70.0	70.0	60.0	35.0	32.0
11.0	73.7	70.0	70.0	60.0	35.0	32.0
12.0	66.6	68.3	69.2	60.0	35.0	32.0
14.0		56.0	56.8	53.8	35.0	32.0
16.0		46.9	47.7	47.4	35.0	28.7
18.0			40.6	41.3	32.1	25.3
20.0			35.1	35.7	28.7	22.5
22.0			30.6	31.1	25.7	20.2
24.0				27.4	23.2	18.2
26.0				24.2	21.0	16.5
28.0				21.6	19.1	15.0
30.0					17.5	13.7
32.0					16.1	12.6
34.0					14.8	11.6
36.0					13.6	10.7
38.0						9.9
40.0						9.2
42.0						8.6
危険角度 (°)	—	—	—	—	—	—
フック種類	150t	83t	83t	83t	83t	83t
フック質量 (t)	1.90	1.0	1.0	1.0	1.0	1.0
巻掛本数	14	7	7	6	4	4

(単位 : ton)



14.4m — 44.7m

メインブーム【特殊伸縮】

TD3性能

カウンタウエイト 69t アウトリガ張出 7.4m (側方)

作業半径 (m)	14.4m ブーム	19.55m ブーム	24.7m ブーム	32.0m ブーム	40.0m ブーム	44.7m ブーム
3.0	150.0					
3.5	150.0	70.0				
4.0	150.0	70.0	70.0			
4.5	150.0	70.0	70.0			
5.0	150.0	70.0	70.0	60.0		
6.0	132.0	70.0	70.0	60.0		
7.0	115.0	70.0	70.0	60.0	35.0	
8.0	101.5	70.0	70.0	60.0	35.0	32.0
9.0	90.5	70.0	70.0	60.0	35.0	32.0
10.0	81.4	70.0	70.0	60.0	35.0	32.0
11.0	73.7	70.0	70.0	60.0	35.0	32.0
12.0	66.3	67.9	68.7	60.0	35.0	32.0
14.0		52.8	53.5	53.8	35.0	32.0
16.0		42.6	43.3	43.8	35.0	28.7
18.0			35.9	36.4	32.1	25.3
20.0			30.4	30.9	28.7	22.5
22.0			26.1	26.5	25.7	20.2
24.0				23.1	23.2	18.2
26.0				20.2	20.5	16.5
28.0				17.9	18.2	15.0
30.0					16.1	13.7
32.0					14.4	12.6
34.0					12.9	11.6
36.0					11.6	10.7
38.0						9.9
40.0						9.2
42.0						8.6
危険角度 (°)	—	—	—	—	—	—
フック種類	150t	83t	83t	83t	83t	83t
フック質量 (t)	1.90	1.0	1.0	1.0	1.0	1.0
巻掛本数	14	7	7	6	4	4

(単位 : ton)



14.4m — 44.7m

メインブーム【特殊伸縮】

TE1性能

カウンタウエイト 51t アウトリガ張出 9.4m (全周)

作業半径 (m)	14.4m ブーム	19.55m ブーム	24.7m ブーム	32.0m ブーム	40.0m ブーム	44.7m ブーム
3.0	150.0					
3.5	150.0	70.0				
4.0	150.0	70.0	70.0			
4.5	150.0	70.0	70.0			
5.0	146.7	70.0	70.0	60.0		
6.0	125.5	70.0	70.0	60.0		
7.0	109.3	70.0	70.0	60.0	35.0	
8.0	96.3	70.0	70.0	60.0	35.0	32.0
9.0	85.1	70.0	70.0	60.0	35.0	32.0
10.0	74.4	70.0	70.0	60.0	35.0	32.0
11.0	65.8	67.6	68.5	60.0	35.0	32.0
12.0	58.7	60.4	61.3	60.0	35.0	32.0
14.0		49.3	50.1	50.8	35.0	32.0
16.0		41.0	41.8	42.5	35.0	28.7
18.0			35.5	36.1	32.1	25.3
20.0			30.4	31.0	28.7	22.5
22.0			26.4	26.9	25.7	20.2
24.0				23.5	23.2	18.2
26.0				20.7	21.0	16.5
28.0				18.3	18.6	15.0
30.0					16.5	13.7
32.0					14.7	12.6
34.0					13.1	11.6
36.0					11.7	10.7
38.0						9.9
40.0						9.2
42.0						8.3
危険角度 (°)	—	—	—	—	—	—
フック種類	150t	83t	83t	83t	83t	83t
フック質量 (t)	1.90	1.0	1.0	1.0	1.0	1.0
巻掛本数	14	7	7	6	4	4

(単位 : ton)

TE2性能

カウンタウエイト 51t アウトリガ張出 8.4m (側方)

作業半径 (m)	14.4m ブーム	19.55m ブーム	24.7m ブーム	32.0m ブーム	40.0m ブーム	44.7m ブーム
3.0	150.0					
3.5	150.0	70.0				
4.0	150.0	70.0	70.0			
4.5	150.0	70.0	70.0			
5.0	146.7	70.0	70.0	60.0		
6.0	125.5	70.0	70.0	60.0		
7.0	109.3	70.0	70.0	60.0	35.0	
8.0	96.3	70.0	70.0	60.0	35.0	32.0
9.0	85.1	70.0	70.0	60.0	35.0	32.0
10.0	74.4	70.0	70.0	60.0	35.0	32.0
11.0	65.8	67.6	68.5	60.0	35.0	32.0
12.0	58.7	60.4	61.3	60.0	35.0	32.0
14.0		49.3	50.1	50.8	35.0	32.0
16.0		41.0	41.8	42.5	35.0	28.7
18.0			35.5	36.1	32.1	25.3
20.0			30.3	30.8	28.7	22.5
22.0			25.8	26.3	25.7	20.2
24.0				22.7	23.1	18.2
26.0				19.8	20.1	16.5
28.0				17.4	17.7	15.0
30.0					15.6	13.7
32.0					13.8	12.6
34.0					12.3	11.6
36.0					11.0	10.7
38.0						9.9
40.0						8.9
42.0						8.0
危険角度 (°)	—	—	—	—	—	—
フック種類	150t	83t	83t	83t	83t	83t
フック質量 (t)	1.90	1.0	1.0	1.0	1.0	1.0
巻掛本数	14	7	7	6	4	4

(単位 : ton)



14.4m — 44.7m

メインブーム【特殊伸縮】

TE3性能

カウンタウエイト 51t アウトリガ張出 7.4m (側方)

作業半径 (m)	14.4m ブーム	19.55m ブーム	24.7m ブーム	32.0m ブーム	40.0m ブーム	44.7m ブーム
3.0	150.0					
3.5	150.0	70.0				
4.0	150.0	70.0	70.0			
4.5	150.0	70.0	70.0			
5.0	146.7	70.0	70.0	60.0		
6.0	125.5	70.0	70.0	60.0		
7.0	109.3	70.0	70.0	60.0	35.0	
8.0	96.3	70.0	70.0	60.0	35.0	32.0
9.0	85.1	70.0	70.0	60.0	35.0	32.0
10.0	74.4	70.0	70.0	60.0	35.0	32.0
11.0	63.3	65.0	65.8	60.0	35.0	32.0
12.0	54.4	56.0	56.8	57.4	35.0	32.0
14.0		43.2	43.9	44.5	35.0	32.0
16.0		34.6	35.2	35.8	35.0	28.7
18.0			29.0	29.5	30.0	25.3
20.0			24.3	24.8	25.2	22.5
22.0			20.7	21.1	21.5	20.2
24.0				18.2	18.5	18.2
26.0				15.8	16.1	16.2
28.0				13.8	14.1	14.2
30.0					12.4	12.4
32.0					10.9	11.0
34.0					9.6	9.7
36.0					8.6	8.6
38.0						7.6
40.0						6.8
42.0						6.0
危険角度 (°)	—	—	—	—	—	—
フック種類	150t	83t	83t	83t	83t	83t
フック質量 (t)	1.90	1.0	1.0	1.0	1.0	1.0
巻掛本数	14	7	7	6	4	4

(単位 : ton)



14.4m — 44.7m

メインブーム【特殊伸縮】

TF1性能

カウンタウエイト 41t アウトリガ張出 9.4m (全周)

作業半径 (m)	14.4m ブーム	19.55m ブーム	24.7m ブーム	32.0m ブーム	40.0m ブーム	44.7m ブーム
3.0	150.0					
3.5	150.0	70.0				
4.0	150.0	70.0	70.0			
4.5	150.0	70.0	70.0			
5.0	141.8	70.0	70.0	60.0		
6.0	121.4	70.0	70.0	60.0		
7.0	105.6	70.0	70.0	60.0	35.0	
8.0	91.4	70.0	70.0	60.0	35.0	32.0
9.0	78.7	70.0	70.0	60.0	35.0	32.0
10.0	68.6	70.0	70.0	60.0	35.0	32.0
11.0	60.6	62.4	63.2	60.0	35.0	32.0
12.0	53.9	55.7	56.5	57.2	35.0	32.0
14.0		45.2	46.0	46.7	35.0	32.0
16.0		37.5	38.3	38.9	35.0	28.7
18.0			32.4	33.0	32.1	25.3
20.0			27.6	28.2	28.7	22.5
22.0			23.8	24.4	24.8	20.2
24.0				21.2	21.6	18.2
26.0				18.5	18.9	16.5
28.0				16.3	16.6	15.0
30.0					14.6	13.7
32.0					12.9	12.6
34.0					11.4	11.5
36.0					10.1	10.1
38.0						9.0
40.0						7.9
42.0						7.0
危険角度 (°)	—	—	—	—	—	—
フック種類	150t	83t	83t	83t	83t	83t
フック質量 (t)	1.90	1.0	1.0	1.0	1.0	1.0
巻掛本数	14	7	7	6	4	4

(単位 : ton)

TF2性能

カウンタウエイト 41t アウトリガ張出 8.4m (側方)

作業半径 (m)	14.4m ブーム	19.55m ブーム	24.7m ブーム	32.0m ブーム	40.0m ブーム	44.7m ブーム
3.0	150.0					
3.5	150.0	70.0				
4.0	150.0	70.0	70.0			
4.5	150.0	70.0	70.0			
5.0	141.8	70.0	70.0	60.0		
6.0	121.4	70.0	70.0	60.0		
7.0	105.6	70.0	70.0	60.0	35.0	
8.0	91.4	70.0	70.0	60.0	35.0	32.0
9.0	78.7	70.0	70.0	60.0	35.0	32.0
10.0	68.6	70.0	70.0	60.0	35.0	32.0
11.0	60.6	62.4	63.2	60.0	35.0	32.0
12.0	53.9	55.7	56.5	57.2	35.0	32.0
14.0		45.2	46.0	46.7	35.0	32.0
16.0		37.5	38.3	38.9	35.0	28.7
18.0			31.3	31.9	32.1	25.3
20.0			26.1	26.7	27.1	22.5
22.0			22.1	22.6	23.0	20.2
24.0				19.4	19.8	18.2
26.0				16.8	17.1	16.5
28.0				14.6	14.9	15.0
30.0					13.0	13.1
32.0					11.5	11.5
34.0					10.1	10.2
36.0					8.9	9.0
38.0						7.9
40.0						7.0
42.0						6.0
危険角度 (°)	—	—	—	—	—	—
フック種類	150t	83t	83t	83t	83t	83t
フック質量 (t)	1.90	1.0	1.0	1.0	1.0	1.0
巻掛本数	14	7	7	6	4	4

(単位 : ton)



14.4m — 44.7m

メインブーム【特殊伸縮】

TF3性能

カウンタウエイト 41t アウトリガ張出 7.4m (側方)

作業半径 (m)	14.4m ブーム	19.55m ブーム	24.7m ブーム	32.0m ブーム	40.0m ブーム	44.7m ブーム
3.0	150.0					
3.5	150.0	70.0				
4.0	150.0	70.0	70.0			
4.5	150.0	70.0	70.0			
5.0	141.8	70.0	70.0	60.0		
6.0	121.4	70.0	70.0	60.0		
7.0	105.6	70.0	70.0	60.0	35.0	
8.0	91.4	70.0	70.0	60.0	35.0	32.0
9.0	78.7	70.0	70.0	60.0	35.0	32.0
10.0	65.8	67.7	68.6	60.0	35.0	32.0
11.0	55.3	57.1	57.9	58.6	35.0	32.0
12.0	47.4	49.0	49.8	50.4	35.0	32.0
14.0		37.6	38.3	38.9	35.0	32.0
16.0		29.9	30.5	31.1	31.5	28.7
18.0			25.0	25.5	25.9	25.3
20.0			20.8	21.3	21.7	21.8
22.0			17.5	18.0	18.3	18.4
24.0				15.3	15.7	15.8
26.0				13.2	13.5	13.6
28.0				11.4	11.7	11.8
30.0					10.2	10.2
32.0					8.9	8.9
34.0					7.7	7.8
36.0					6.8	6.8
38.0						5.9
40.0						5.2
42.0						4.3
危険角度 (°)	—	—	—	—	—	—
フック種類	150t	83t	83t	83t	83t	83t
フック質量 (t)	1.90	1.0	1.0	1.0	1.0	1.0
巻掛本数	14	7	7	6	4	4

(単位 : ton)

TF4性能

カウンタウエイト 41t アウトリガ張出 6.4m (側方)

作業半径 (m)	14.4m ブーム	19.55m ブーム	24.7m ブーム	32.0m ブーム	40.0m ブーム	44.7m ブーム
3.0	150.0					
3.5	150.0	70.0				
4.0	150.0	70.0	70.0			
4.5	150.0	70.0	70.0			
5.0	141.8	70.0	70.0	60.0		
6.0	121.4	70.0	70.0	60.0		
7.0	105.6	70.0	70.0	60.0	35.0	
8.0	81.3	70.0	70.0	60.0	35.0	32.0
9.0	65.4	67.3	68.1	60.0	35.0	32.0
10.0	54.1	55.9	56.7	57.4	35.0	32.0
11.0	45.8	47.4	48.2	48.8	35.0	32.0
12.0	39.4	40.9	41.6	42.3	35.0	32.0
14.0		31.5	32.2	32.7	33.2	32.0
16.0		25.0	25.7	26.2	26.7	26.8
18.0			21.0	21.5	21.9	22.0
20.0			17.4	17.8	18.2	18.3
22.0			14.6	15.0	15.4	15.5
24.0				12.7	13.1	13.1
26.0				10.8	11.2	11.2
28.0				9.3	9.6	9.6
30.0					8.2	8.3
32.0					7.1	7.1
34.0					6.1	6.1
36.0					5.2	5.3
38.0						4.3
40.0						3.4
危険角度 (°)	—	—	—	—	—	21
フック種類	150t	83t	83t	83t	83t	83t
フック質量 (t)	1.90	1.0	1.0	1.0	1.0	1.0
巻掛本数	14	7	7	6	4	4

(単位 : ton)



14.4m — 44.7m

メインブーム【特殊伸縮】

TG1性能

カウンタウエイト 31t アウトリガ張出 9.4m (全周)

作業半径 (m)	14.4m ブーム	19.55m ブーム	24.7m ブーム	32.0m ブーム	40.0m ブーム	44.7m ブーム
3.0	150.0					
3.5	150.0	70.0				
4.0	150.0	70.0	70.0			
4.5	149.3	70.0	70.0			
5.0	137.0	70.0	70.0	60.0		
6.0	117.2	70.0	70.0	60.0		
7.0	99.5	70.0	70.0	60.0	35.0	
8.0	84.0	70.0	70.0	60.0	35.0	32.0
9.0	72.2	70.0	70.0	60.0	35.0	32.0
10.0	62.9	64.8	65.6	60.0	35.0	32.0
11.0	55.3	57.2	58.0	58.7	35.0	32.0
12.0	49.1	50.9	51.7	52.4	35.0	32.0
14.0		41.1	42.0	42.6	35.0	32.0
16.0		33.9	34.7	35.4	35.0	28.7
18.0			29.2	29.8	30.4	25.3
20.0			24.8	25.4	25.9	22.5
22.0			21.3	21.8	22.3	20.2
24.0				18.8	19.3	18.2
26.0				16.2	16.6	16.5
28.0				14.1	14.4	14.5
30.0					12.5	12.6
32.0					11.0	11.0
34.0					9.6	9.7
36.0					8.5	8.5
38.0						7.5
40.0						6.4
42.0						5.5
危険角度 (°)	—	—	—	—	—	—
フック種類	150t	83t	83t	83t	83t	83t
フック質量 (t)	1.90	1.0	1.0	1.0	1.0	1.0
巻掛本数	14	7	7	6	4	4

(単位 : ton)

TG2性能

カウンタウエイト 31t アウトリガ張出 8.4m (側方)

作業半径 (m)	14.4m ブーム	19.55m ブーム	24.7m ブーム	32.0m ブーム	40.0m ブーム	44.7m ブーム
3.0	150.0					
3.5	150.0	70.0				
4.0	150.0	70.0	70.0			
4.5	149.3	70.0	70.0			
5.0	137.0	70.0	70.0	60.0		
6.0	117.2	70.0	70.0	60.0		
7.0	99.5	70.0	70.0	60.0	35.0	
8.0	84.0	70.0	70.0	60.0	35.0	32.0
9.0	72.2	70.0	70.0	60.0	35.0	32.0
10.0	62.9	64.8	65.6	60.0	35.0	32.0
11.0	55.3	57.2	58.0	58.7	35.0	32.0
12.0	49.1	50.9	51.7	52.4	35.0	32.0
14.0		40.7	41.5	42.2	35.0	32.0
16.0		32.0	32.8	33.4	33.9	28.7
18.0			26.6	27.1	27.6	25.3
20.0			22.0	22.5	23.0	22.5
22.0			18.4	18.9	19.3	19.4
24.0				16.1	16.4	16.5
26.0				13.7	14.1	14.2
28.0				11.8	12.1	12.2
30.0					10.5	10.6
32.0					9.1	9.2
34.0					7.9	8.0
36.0					6.8	6.8
38.0						5.7
40.0						4.7
42.0						3.9
危険角度 (°)	—	—	—	—	—	—
フック種類	150t	83t	83t	83t	83t	83t
フック質量 (t)	1.90	1.0	1.0	1.0	1.0	1.0
巻掛本数	14	7	7	6	4	4

(単位 : ton)



14.4m — 44.7m

メインブーム【特殊伸縮】

TG3性能

カウンタウエイト 31t アウトリガ張出 7.4m (側方)

作業半径 (m)	14.4m ブーム	19.55m ブーム	24.7m ブーム	32.0m ブーム	40.0m ブーム	44.7m ブーム
3.0	150.0					
3.5	150.0	70.0				
4.0	150.0	70.0	70.0			
4.5	149.3	70.0	70.0			
5.0	137.0	70.0	70.0	60.0		
6.0	117.2	70.0	70.0	60.0		
7.0	99.5	70.0	70.0	60.0	35.0	
8.0	84.0	70.0	70.0	60.0	35.0	32.0
9.0	69.4	70.0	70.0	60.0	35.0	32.0
10.0	56.6	58.5	59.4	60.0	35.0	32.0
11.0	47.4	49.1	49.9	50.6	35.0	32.0
12.0	40.4	42.0	42.8	43.4	35.0	32.0
14.0		31.9	32.6	33.2	33.7	32.0
16.0		25.1	25.8	26.4	26.8	26.9
18.0			20.9	21.4	21.9	21.9
20.0			17.2	17.7	18.1	18.2
22.0			14.4	14.8	15.2	15.3
24.0				12.5	12.8	12.9
26.0				10.6	10.9	11.0
28.0				9.0	9.3	9.4
30.0					8.0	8.0
32.0					6.8	6.9
34.0					5.8	5.9
36.0					4.9	4.9
38.0						3.9
40.0						3.1
危険角度 (°)	—	—	—	—	—	21
フック種類	150t	83t	83t	83t	83t	83t
フック質量 (t)	1.90	1.0	1.0	1.0	1.0	1.0
巻掛本数	14	7	7	6	4	4

(単位 : ton)

TG4性能

カウンタウエイト 31t アウトリガ張出 6.4m (側方)

作業半径 (m)	14.4m ブーム	19.55m ブーム	24.7m ブーム	32.0m ブーム	40.0m ブーム	44.7m ブーム
3.0	150.0					
3.5	150.0	70.0				
4.0	150.0	70.0	70.0			
4.5	149.3	70.0	70.0			
5.0	137.0	70.0	70.0	60.0		
6.0	117.2	70.0	70.0	60.0		
7.0	91.2	70.0	70.0	60.0	35.0	
8.0	69.9	70.0	70.0	60.0	35.0	32.0
9.0	55.9	57.8	58.7	59.4	35.0	32.0
10.0	46.0	47.8	48.6	49.3	35.0	32.0
11.0	38.7	40.4	41.2	41.8	35.0	32.0
12.0	33.1	34.7	35.4	36.0	35.0	32.0
14.0		26.4	27.1	27.7	28.2	28.3
16.0		20.8	21.4	21.9	22.4	22.5
18.0			17.3	17.8	18.2	18.3
20.0			14.1	14.6	15.0	15.1
22.0			11.7	12.1	12.5	12.5
24.0				10.1	10.4	10.5
26.0				8.4	8.8	8.8
28.0				7.1	7.4	7.4
30.0					6.2	6.3
32.0					5.2	5.2
34.0					4.0	4.1
36.0					3.0	3.1
危険角度 (°)	—	—	—	—	19	33
フック種類	150t	83t	83t	83t	83t	83t
フック質量 (t)	1.90	1.0	1.0	1.0	1.0	1.0
巻掛本数	14	7	7	6	4	4

(単位 : ton)



14.4m — 44.7m

メインブーム【特殊伸縮】

TH1性能

カウンタウエイト 21t アウトリガ張出 9.4m (全周)

作業半径 (m)	14.4m ブーム	19.55m ブーム	24.7m ブーム	32.0m ブーム	40.0m ブーム	44.7m ブーム
3.0	150.0					
3.5	150.0	70.0				
4.0	150.0	70.0	70.0			
4.5	144.2	70.0	70.0			
5.0	132.2	70.0	70.0	60.0		
6.0	110.7	70.0	70.0	60.0		
7.0	91.1	70.0	70.0	60.0	35.0	
8.0	76.7	70.0	70.0	60.0	35.0	32.0
9.0	65.7	67.7	68.6	60.0	35.0	32.0
10.0	57.1	59.0	59.8	60.0	35.0	32.0
11.0	50.1	51.9	52.8	53.5	35.0	32.0
12.0	44.3	46.1	46.9	47.7	35.0	32.0
14.0		37.1	37.9	38.6	35.0	32.0
16.0		30.4	31.2	31.9	32.4	28.7
18.0			25.9	26.5	27.0	25.3
20.0			21.2	21.7	22.2	22.3
22.0			17.7	18.1	18.6	18.7
24.0				15.3	15.7	15.8
26.0				13.0	13.4	13.4
28.0				11.1	11.4	11.5
30.0					9.8	9.9
32.0					8.4	8.5
34.0					7.2	7.3
36.0					6.0	6.1
38.0						5.0
40.0						4.0
42.0						3.2
危険角度 (°)	—	—	—	—	—	—
フック種類	150t	83t	83t	83t	83t	83t
フック質量 (t)	1.90	1.0	1.0	1.0	1.0	1.0
巻掛本数	14	7	7	6	4	4

(単位 : ton)

TH2性能

カウンタウエイト 21t アウトリガ張出 8.4m (側方)

作業半径 (m)	14.4m ブーム	19.55m ブーム	24.7m ブーム	32.0m ブーム	40.0m ブーム	44.7m ブーム
3.0	150.0					
3.5	150.0	70.0				
4.0	150.0	70.0	70.0			
4.5	144.2	70.0	70.0			
5.0	132.2	70.0	70.0	60.0		
6.0	110.7	70.0	70.0	60.0		
7.0	91.1	70.0	70.0	60.0	35.0	
8.0	76.7	70.0	70.0	60.0	35.0	32.0
9.0	65.7	67.7	68.6	60.0	35.0	32.0
10.0	57.1	59.0	59.8	60.0	35.0	32.0
11.0	50.1	51.9	52.8	53.5	35.0	32.0
12.0	43.6	45.4	46.3	47.1	35.0	32.0
14.0		34.0	34.8	35.5	35.0	32.0
16.0		26.4	27.2	27.8	28.3	28.5
18.0			21.8	22.4	22.9	23.0
20.0			17.8	18.3	18.8	18.9
22.0			14.8	15.2	15.6	15.7
24.0				12.7	13.1	13.2
26.0				10.7	11.1	11.2
28.0				9.1	9.4	9.5
30.0					7.9	8.0
32.0					6.6	6.7
34.0					5.3	5.4
36.0					4.2	4.3
38.0						3.3
危険角度 (°)	—	—	—	—	—	27
フック種類	150t	83t	83t	83t	83t	83t
フック質量 (t)	1.90	1.0	1.0	1.0	1.0	1.0
巻掛本数	14	7	7	6	4	4

(単位 : ton)



14.4m — 44.7m

メインブーム【特殊伸縮】

TH3性能

カウンタウエイト 21t アウトリガ張出 7.4m (側方)

作業半径 (m)	14.4m ブーム	19.55m ブーム	24.7m ブーム	32.0m ブーム	40.0m ブーム	44.7m ブーム
3.0	150.0					
3.5	150.0	70.0				
4.0	150.0	70.0	70.0			
4.5	144.2	70.0	70.0			
5.0	132.2	70.0	70.0	60.0		
6.0	110.7	70.0	70.0	60.0		
7.0	91.1	70.0	70.0	60.0	35.0	
8.0	74.6	70.0	70.0	60.0	35.0	32.0
9.0	58.4	60.5	61.4	60.0	35.0	32.0
10.0	47.4	49.3	50.2	50.9	35.0	32.0
11.0	39.4	41.2	42.0	42.7	35.0	32.0
12.0	33.4	35.0	35.8	36.4	35.0	32.0
14.0		26.3	27.0	27.6	28.1	28.2
16.0		20.4	21.1	21.6	22.1	22.2
18.0			16.8	17.4	17.8	17.9
20.0			13.7	14.1	14.5	14.6
22.0			11.2	11.6	12.0	12.1
24.0				9.6	10.0	10.1
26.0				8.0	8.3	8.4
28.0				6.6	6.9	7.0
30.0					5.8	5.8
32.0					4.6	4.7
34.0					3.5	3.6
危険角度 (°)	—	—	—	—	27	37
フック種類	150t	83t	83t	83t	83t	83t
フック質量 (t)	1.90	1.0	1.0	1.0	1.0	1.0
巻掛本数	14	7	7	6	4	4

(単位 : ton)

TH4性能

カウンタウエイト 21t アウトリガ張出 6.4m (側方)

作業半径 (m)	14.4m ブーム	19.55m ブーム	24.7m ブーム	32.0m ブーム	40.0m ブーム	44.7m ブーム
3.0	150.0					
3.5	150.0	70.0				
4.0	150.0	70.0	70.0			
4.5	144.2	70.0	70.0			
5.0	132.2	70.0	70.0	60.0		
6.0	108.3	70.0	70.0	60.0		
7.0	76.8	70.0	70.0	60.0	35.0	
8.0	58.5	60.6	61.5	60.0	35.0	32.0
9.0	46.5	48.4	49.2	50.0	35.0	32.0
10.0	38.0	39.8	40.6	41.3	35.0	32.0
11.0	31.8	33.4	34.2	34.8	35.0	32.0
12.0	26.9	28.5	29.2	29.8	30.3	30.5
14.0		21.4	22.0	22.6	23.1	23.2
16.0		16.5	17.1	17.7	18.1	18.2
18.0			13.6	14.1	14.5	14.6
20.0			10.9	11.3	11.7	11.8
22.0			8.8	9.2	9.6	9.6
24.0				7.5	7.8	7.9
26.0				6.1	6.4	6.4
28.0				4.7	5.1	5.2
30.0					3.8	3.9
危険角度 (°)	—	—	—	—	38	45
フック種類	150t	83t	83t	83t	83t	83t
フック質量 (t)	1.90	1.0	1.0	1.0	1.0	1.0
巻掛本数	14	7	7	6	4	4

(単位 : ton)



14.4m — 44.7m

メインブーム【特殊伸縮】

TH5性能

カウンタウエイト 21t アウトリガ張出 5.4m (側方)

作業半径 (m)	14.4m ブーム	19.55m ブーム	24.7m ブーム	32.0m ブーム	40.0m ブーム	44.7m ブーム
3.0	150.0					
3.5	150.0	70.0				
4.0	150.0	70.0	70.0			
4.5	144.2	70.0	70.0			
5.0	111.8	70.0	70.0	60.0		
6.0	74.8	70.0	70.0	60.0		
7.0	54.9	56.9	57.7	58.5	35.0	
8.0	42.6	44.4	45.1	45.8	35.0	32.0
9.0	34.2	35.8	36.5	37.2	35.0	32.0
10.0	28.1	29.6	30.3	30.9	31.4	31.5
11.0	23.4	24.9	25.6	26.1	26.6	26.7
12.0	19.8	21.2	21.9	22.4	22.9	23.0
14.0		15.8	16.4	16.9	17.4	17.5
16.0		12.0	12.6	13.1	13.5	13.6
18.0			9.8	10.3	10.7	10.8
20.0			7.7	8.1	8.5	8.6
22.0			6.1	6.4	6.8	6.9
24.0				5.1	5.4	5.5
26.0				3.8	4.2	4.3
28.0						3.1
危険角度 (°)	—	—	—	30	47	49
フック種類	150t	83t	83t	83t	83t	83t
フック質量 (t)	1.90	1.0	1.0	1.0	1.0	1.0
巻掛本数	14	7	7	6	4	4

(単位 : ton)



14.4m — 44.7m

メインブーム【特殊伸縮】

TJ1性能

カウンタウエイト 11t アウトリガ張出 9.4m (全周)

作業半径 (m)	14.4m ブーム	19.55m ブーム	24.7m ブーム	32.0m ブーム	40.0m ブーム	44.7m ブーム
3.0	150.0					
3.5	150.0	70.0				
4.0	150.0	70.0	70.0			
4.5	139.0	70.0	70.0			
5.0	126.9	70.0	70.0	60.0		
6.0	100.8	70.0	70.0	60.0		
7.0	82.7	70.0	70.0	60.0	35.0	
8.0	69.4	70.0	70.0	60.0	35.0	32.0
9.0	59.3	61.2	62.1	60.0	35.0	32.0
10.0	51.3	53.2	54.1	54.8	35.0	32.0
11.0	44.9	46.7	47.6	48.3	35.0	32.0
12.0	39.6	41.3	42.2	42.9	35.0	32.0
14.0		33.0	33.8	34.5	35.0	32.0
16.0		25.3	26.1	26.7	27.3	27.4
18.0			20.6	21.2	21.7	21.9
20.0			16.7	17.2	17.7	17.8
22.0			13.7	14.1	14.6	14.7
24.0				11.7	12.1	12.2
26.0				9.7	10.1	10.2
28.0				8.1	8.4	8.5
30.0					7.0	7.1
32.0					5.6	5.7
34.0					4.4	4.4
36.0					3.3	3.4
危険角度 (°)	—	—	—	—	15	33
フック種類	150t	83t	83t	83t	83t	83t
フック質量 (t)	1.90	1.0	1.0	1.0	1.0	1.0
巻掛本数	14	7	7	6	4	4

(単位 : ton)

TJ2性能

カウンタウエイト 11t アウトリガ張出 8.4m (側方)

作業半径 (m)	14.4m ブーム	19.55m ブーム	24.7m ブーム	32.0m ブーム	40.0m ブーム	44.7m ブーム
3.0	150.0					
3.5	150.0	70.0				
4.0	150.0	70.0	70.0			
4.5	139.0	70.0	70.0			
5.0	126.9	70.0	70.0	60.0		
6.0	100.8	70.0	70.0	60.0		
7.0	82.7	70.0	70.0	60.0	35.0	
8.0	69.4	70.0	70.0	60.0	35.0	32.0
9.0	59.3	61.2	62.1	60.0	35.0	32.0
10.0	51.3	53.2	54.1	54.8	35.0	32.0
11.0	42.0	44.0	45.0	45.8	35.0	32.0
12.0	35.1	37.0	37.9	38.6	35.0	32.0
14.0		27.3	28.1	28.8	29.3	29.5
16.0		20.9	21.6	22.2	22.8	22.9
18.0			17.0	17.6	18.1	18.2
20.0			13.7	14.2	14.6	14.7
22.0			11.1	11.5	11.9	12.0
24.0				9.4	9.8	9.9
26.0				7.7	8.1	8.1
28.0				6.0	6.5	6.6
30.0					5.0	5.1
32.0					3.7	3.8
危険角度 (°)	—	—	—	—	33	41
フック種類	150t	83t	83t	83t	83t	83t
フック質量 (t)	1.90	1.0	1.0	1.0	1.0	1.0
巻掛本数	14	7	7	6	4	4

(単位 : ton)



14.4m — 44.7m

メインブーム【特殊伸縮】

TJ3性能

カウンタウエイト 11t アウトリガ張出 7.4m (側方)

作業半径 (m)	14.4m ブーム	19.55m ブーム	24.7m ブーム	32.0m ブーム	40.0m ブーム	44.7m ブーム
3.0	150.0					
3.5	150.0	70.0				
4.0	150.0	70.0	70.0			
4.5	139.0	70.0	70.0			
5.0	126.9	70.0	70.0	60.0		
6.0	100.8	70.0	70.0	60.0		
7.0	82.7	70.0	70.0	60.0	35.0	
8.0	61.1	63.5	64.5	60.0	35.0	32.0
9.0	47.5	49.6	50.5	51.3	35.0	32.0
10.0	38.2	40.1	41.0	41.7	35.0	32.0
11.0	31.5	33.2	34.0	34.7	35.0	32.0
12.0	26.4	28.0	28.8	29.5	30.0	30.1
14.0		20.7	21.4	22.0	22.5	22.6
16.0		15.7	16.4	16.9	17.4	17.5
18.0			12.8	13.3	13.7	13.8
20.0			10.1	10.6	11.0	11.1
22.0			8.0	8.5	8.8	8.9
24.0				6.8	7.1	7.2
26.0				5.4	5.7	5.8
28.0				3.9	4.3	4.4
30.0					3.0	3.1
危険角度 (°)	—	—	—	22	37	45
フック種類	150t	83t	83t	83t	83t	83t
フック質量 (t)	1.90	1.0	1.0	1.0	1.0	1.0
巻掛本数	14	7	7	6	4	4

(単位 : ton)

TJ4性能

カウンタウエイト 11t アウトリガ張出 6.4m (側方)

作業半径 (m)	14.4m ブーム	19.55m ブーム	24.7m ブーム	32.0m ブーム	40.0m ブーム	44.7m ブーム
3.0	150.0					
3.5	150.0	70.0				
4.0	150.0	70.0	70.0			
4.5	139.0	70.0	70.0			
5.0	126.9	70.0	70.0	60.0		
6.0	88.8	70.0	70.0	60.0		
7.0	62.4	64.8	65.8	60.0	35.0	
8.0	47.1	49.2	50.1	50.9	35.0	32.0
9.0	37.1	39.0	39.8	40.5	35.0	32.0
10.0	30.0	31.8	32.6	33.2	33.8	32.0
11.0	24.7	26.4	27.2	27.8	28.4	28.5
12.0	20.7	22.3	23.0	23.6	24.1	24.2
14.0		16.3	17.0	17.6	18.0	18.1
16.0		12.2	12.9	13.4	13.8	13.9
18.0			9.9	10.4	10.8	10.9
20.0			7.6	8.1	8.5	8.6
22.0			5.9	6.3	6.6	6.7
24.0				4.7	5.2	5.3
26.0				3.1	3.6	3.7
危険角度 (°)	—	—	—	30	47	52
フック種類	150t	83t	83t	83t	83t	83t
フック質量 (t)	1.90	1.0	1.0	1.0	1.0	1.0
巻掛本数	14	7	7	6	4	4

(単位 : ton)



14.4m — 44.7m

メインブーム【特殊伸縮】

TJ5性能

カウンタウエイト 11t アウトリガ張出 5.4m (側方)

作業半径 (m)	14.4m ブーム	19.55m ブーム	24.7m ブーム	32.0m ブーム	40.0m ブーム	44.7m ブーム
3.0	150.0					
3.5	150.0	70.0				
4.0	150.0	70.0	70.0			
4.5	119.1	70.0	70.0			
5.0	90.9	70.0	70.0	60.0		
6.0	60.2	62.4	63.3	60.0		
7.0	43.7	45.7	46.5	47.3	35.0	
8.0	33.5	35.3	36.0	36.7	35.0	32.0
9.0	26.5	28.2	28.9	29.5	30.1	30.2
10.0	21.5	23.0	23.7	24.3	24.8	24.9
11.0	17.6	19.1	19.8	20.3	20.8	20.9
12.0	14.7	16.0	16.7	17.2	17.7	17.8
14.0		11.6	12.2	12.7	13.1	13.2
16.0		8.4	9.0	9.5	9.9	10.0
18.0			6.7	7.1	7.5	7.6
20.0			4.9	5.4	5.7	5.8
22.0			3.3	3.9	4.3	4.4
危険角度 (°)	—	—	—	43	54	58
フック種類	150t	83t	83t	83t	83t	83t
フック質量 (t)	1.90	1.0	1.0	1.0	1.0	1.0
巻掛本数	14	7	7	6	4	4

(単位 : ton)



14.4m — 44.7m

メインブーム【特殊伸縮】

TK1性能

カウンタウエイト 0t アウトリガ張出 9.4m (全周)

作業半径 (m)	14.4m ブーム	19.55m ブーム	24.7m ブーム	32.0m ブーム	40.0m ブーム	44.7m ブーム
3.0	150.0					
3.5	150.0	70.0				
4.0	146.8	70.0	70.0			
4.5	130.4	70.0	70.0			
5.0	114.1	70.0	70.0	60.0		
6.0	90.2	70.0	70.0	60.0		
7.0	73.8	70.0	70.0	60.0	35.0	
8.0	61.7	63.7	64.6	60.0	35.0	32.0
9.0	52.5	54.4	55.3	56.1	35.0	32.0
10.0	45.2	47.1	48.0	48.7	35.0	32.0
11.0	39.3	41.2	42.0	42.8	35.0	32.0
12.0	32.7	34.7	35.6	36.4	35.0	32.0
14.0		24.9	25.8	26.5	27.1	27.2
16.0		18.7	19.4	20.1	20.6	20.8
18.0			15.0	15.6	16.1	16.2
20.0			11.8	12.3	12.8	12.9
22.0			9.3	9.8	10.2	10.3
24.0				7.8	8.2	8.3
26.0				5.9	6.4	6.6
28.0				4.4	4.8	4.9
30.0					3.4	3.5
危険角度 (°)	—	—	—	—	38	45
フック種類	150t	83t	83t	83t	83t	83t
フック質量 (t)	1.90	1.0	1.0	1.0	1.0	1.0
巻掛本数	14	7	7	6	4	4

(単位 : ton)

TK2性能

カウンタウエイト 0t アウトリガ張出 8.4m (側方)

作業半径 (m)	14.4m ブーム	19.55m ブーム	24.7m ブーム	32.0m ブーム	40.0m ブーム	44.7m ブーム
3.0	150.0					
3.5	150.0	70.0				
4.0	146.8	70.0	70.0			
4.5	130.4	70.0	70.0			
5.0	114.1	70.0	70.0	60.0		
6.0	90.2	70.0	70.0	60.0		
7.0	73.8	70.0	70.0	60.0	35.0	
8.0	61.7	63.7	64.6	60.0	35.0	32.0
9.0	49.6	52.1	53.2	53.9	35.0	32.0
10.0	39.0	41.3	42.3	43.1	35.0	32.0
11.0	31.6	33.6	34.5	35.3	35.0	32.0
12.0	26.1	27.9	28.8	29.6	30.2	30.2
14.0		20.1	20.9	21.5	22.1	22.2
16.0		14.9	15.6	16.2	16.8	16.9
18.0			11.9	12.5	13.0	13.1
20.0			9.2	9.7	10.2	10.3
22.0			6.9	7.5	8.0	8.1
24.0				5.5	6.0	6.1
26.0				3.8	4.3	4.4
28.0						3.0
危険角度 (°)	—	—	—	30	47	49
フック種類	150t	83t	83t	83t	83t	83t
フック質量 (t)	1.90	1.0	1.0	1.0	1.0	1.0
巻掛本数	14	7	7	6	4	4

(単位 : ton)



14.4m — 44.7m

メインブーム【特殊伸縮】

TK3性能

カウンタウエイト 0t アウトリガ張出 7.4m (側方)

作業半径 (m)	14.4m ブーム	19.55m ブーム	24.7m ブーム	32.0m ブーム	40.0m ブーム	44.7m ブーム
3.0	150.0					
3.5	150.0	70.0				
4.0	146.8	70.0	70.0			
4.5	130.4	70.0	70.0			
5.0	114.1	70.0	70.0	60.0		
6.0	90.2	70.0	70.0	60.0		
7.0	64.1	66.8	68.0	60.0	35.0	
8.0	46.6	48.9	50.0	50.8	35.0	32.0
9.0	35.7	37.8	38.7	39.5	35.0	32.0
10.0	28.3	30.2	31.1	31.8	32.4	32.0
11.0	22.9	24.7	25.5	26.2	26.8	26.9
12.0	18.9	20.5	21.3	21.9	22.5	22.6
14.0		14.6	15.3	15.9	16.4	16.5
16.0		10.6	11.3	11.8	12.3	12.4
18.0			8.4	8.9	9.4	9.5
20.0			6.3	6.7	7.2	7.2
22.0			4.3	4.9	5.4	5.5
24.0				3.2	3.7	3.8
危険角度 (°)	—	—	—	37	51	55
フック種類	150t	83t	83t	83t	83t	83t
フック質量 (t)	1.90	1.0	1.0	1.0	1.0	1.0
巻掛本数	14	7	7	6	4	4

(単位 : ton)

TK4性能

カウンタウエイト 0t アウトリガ張出 6.4m (側方)

作業半径 (m)	14.4m ブーム	19.55m ブーム	24.7m ブーム	32.0m ブーム	40.0m ブーム	44.7m ブーム
3.0	150.0					
3.5	150.0	70.0				
4.0	146.8	70.0	70.0			
4.5	130.4	70.0	70.0			
5.0	111.7	70.0	70.0	60.0		
6.0	67.8	70.0	70.0	60.0		
7.0	47.0	49.3	50.4	50.1	35.0	
8.0	34.9	36.9	37.9	38.7	35.0	32.0
9.0	26.9	28.8	29.7	30.4	31.0	30.0
10.0	21.3	23.1	23.9	24.6	25.2	25.3
11.0	17.2	18.9	19.6	20.3	20.8	20.9
12.0	14.0	15.6	16.3	16.9	17.5	17.6
14.0		10.9	11.5	12.1	12.6	12.7
16.0		7.6	8.3	8.8	9.3	9.4
18.0			5.9	6.4	6.8	6.9
20.0			3.6	4.3	4.9	5.0
22.0					3.0	
危険角度 (°)	—	—	30	48	55	60
フック種類	150t	83t	83t	83t	83t	83t
フック質量 (t)	1.90	1.0	1.0	1.0	1.0	1.0
巻掛本数	14	7	7	6	4	4

(単位 : ton)

TK5性能

カウンタウエイト 0t アウトリガ張出 5.4m (側方)

作業半径 (m)	14.4m ブーム	19.55m ブーム	24.7m ブーム	32.0m ブーム	40.0m ブーム	44.7m ブーム
3.0	150.0					
3.5	150.0	70.0				
4.0	129.2	70.0	70.0			
4.5	90.4	70.0	70.0			
5.0	68.4	70.0	70.0	60.0		
6.0	44.5	46.7	47.7	47.7		
7.0	31.7	33.7	34.5	35.2	34.8	
8.0	23.7	25.5	26.3	27.0	27.6	27.1
9.0	18.3	20.0	20.7	21.3	21.9	22.0
10.0	14.4	15.9	16.6	17.2	17.7	17.8
11.0	11.4	12.9	13.5	14.1	14.6	14.7
12.0	9.1	10.5	11.1	11.7	12.1	12.2
14.0		7.0	7.6	8.1	8.5	8.6
16.0		4.5	5.1	5.6	6.0	6.1
18.0				3.6	4.2	
危険角度 (°)	—	—	45	53	62	66
フック種類	150t	83t	83t	83t	83t	83t
フック質量 (t)	1.90	1.0	1.0	1.0	1.0	1.0
巻掛本数	14	7	7	6	4	4

(単位 : ton)