

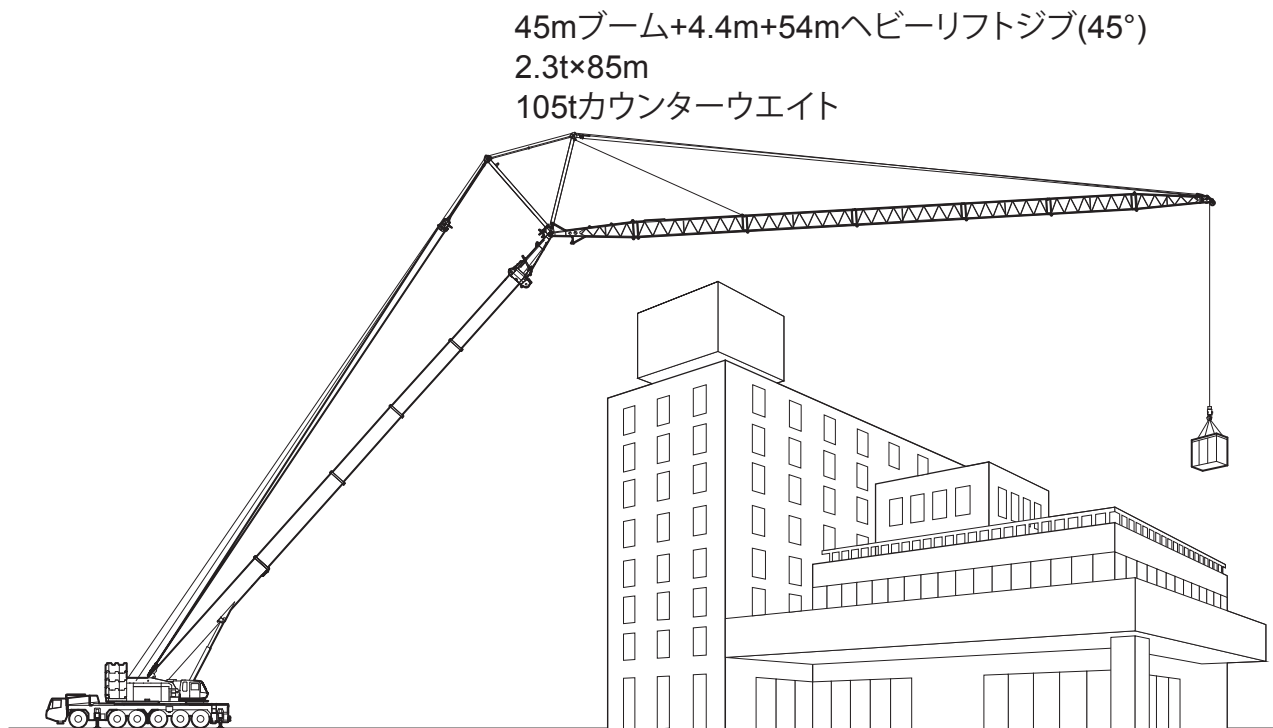

ヘビーリフトジブ作業概念図

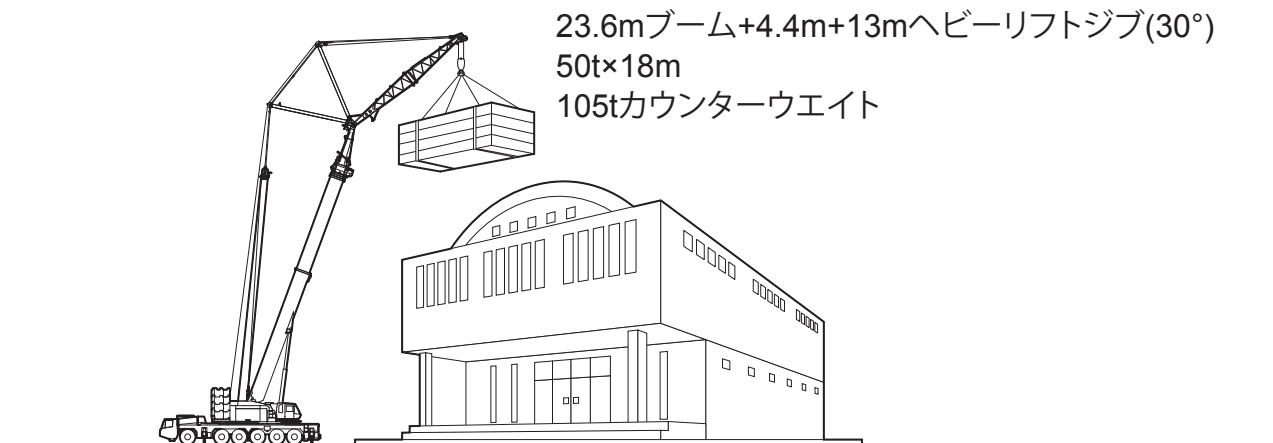



ヘビーリフトジブ作業概念図

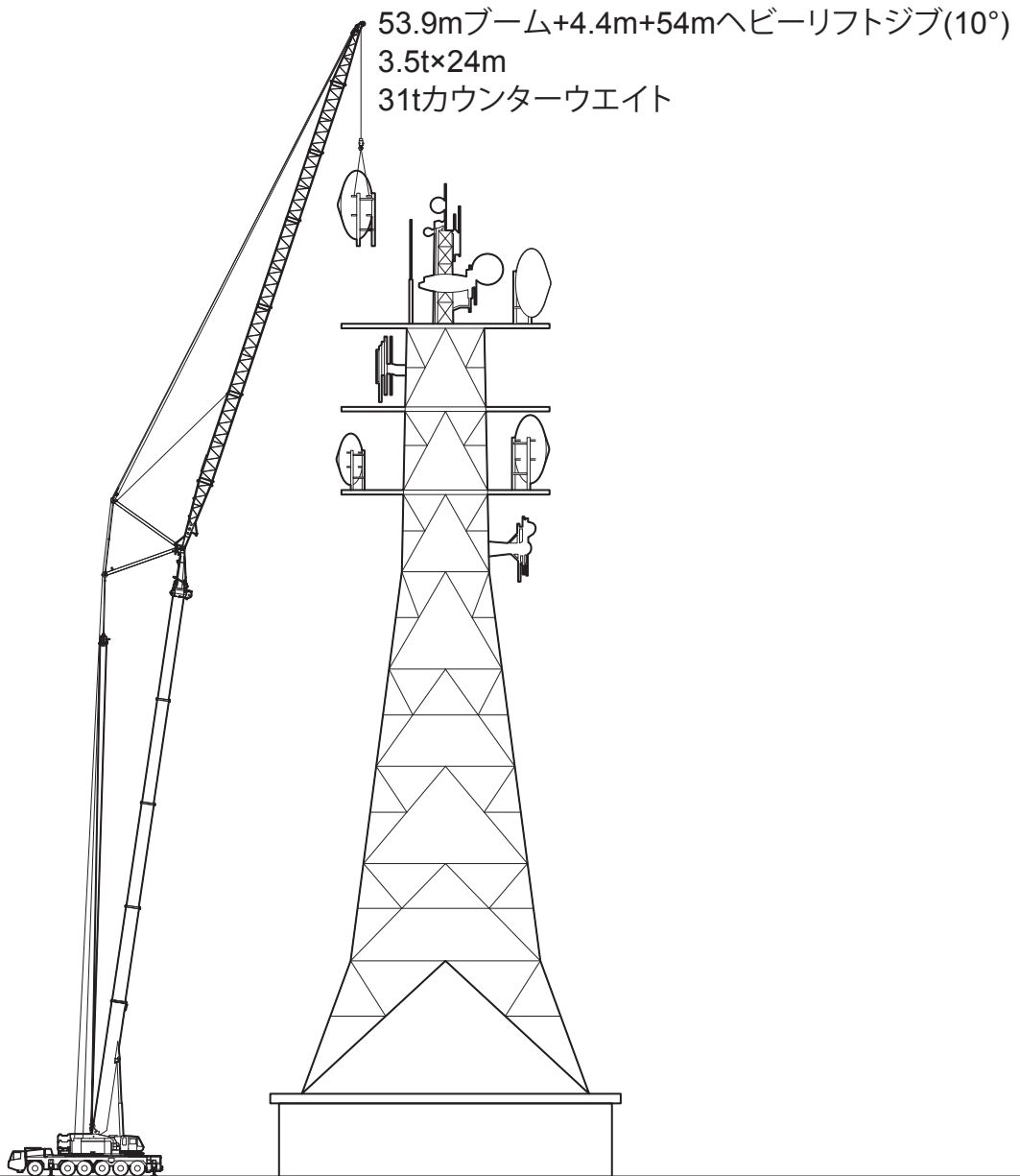



ヘビーリフトジブ作業範囲図

- | | | | |
|----------------------------|----------------------|----------------------------|----------------------|
| (A) 14.4m ブーム + 4.4m + 13m | ヘビーリフトジブ (オフセット 10°) | (M) 53.9m ブーム + 4.4m + 22m | ヘビーリフトジブ (オフセット 10°) |
| (B) 14.4m ブーム + 4.4m + 22m | ヘビーリフトジブ (オフセット 10°) | (N) 53.9m ブーム + 4.4m + 31m | ヘビーリフトジブ (オフセット 10°) |
| (C) 14.4m ブーム + 4.4m + 31m | ヘビーリフトジブ (オフセット 10°) | (O) 53.9m ブーム + 4.4m + 40m | ヘビーリフトジブ (オフセット 10°) |
| (D) 14.4m ブーム + 4.4m + 40m | ヘビーリフトジブ (オフセット 10°) | (P) 53.9m ブーム + 4.4m + 47m | ヘビーリフトジブ (オフセット 10°) |
| (E) 14.4m ブーム + 4.4m + 47m | ヘビーリフトジブ (オフセット 10°) | (Q) 53.9m ブーム + 4.4m + 54m | ヘビーリフトジブ (オフセット 10°) |
| (F) 14.4m ブーム + 4.4m + 54m | ヘビーリフトジブ (オフセット 10°) | (R) 53.9m ブーム + 4.4m + 22m | ヘビーリフトジブ (オフセット 60°) |
| (G) 14.4m ブーム + 4.4m + 13m | ヘビーリフトジブ (オフセット 60°) | (S) 53.9m ブーム + 4.4m + 31m | ヘビーリフトジブ (オフセット 60°) |
| (H) 14.4m ブーム + 4.4m + 22m | ヘビーリフトジブ (オフセット 60°) | (T) 53.9m ブーム + 4.4m + 40m | ヘビーリフトジブ (オフセット 60°) |
| (I) 14.4m ブーム + 4.4m + 31m | ヘビーリフトジブ (オフセット 60°) | (U) 53.9m ブーム + 4.4m + 47m | ヘビーリフトジブ (オフセット 45°) |
| (J) 14.4m ブーム + 4.4m + 40m | ヘビーリフトジブ (オフセット 60°) | (V) 53.9m ブーム + 4.4m + 54m | ヘビーリフトジブ (オフセット 30°) |
| (K) 14.4m ブーム + 4.4m + 47m | ヘビーリフトジブ (オフセット 60°) | | |
| (L) 14.4m ブーム + 4.4m + 54m | ヘビーリフトジブ (オフセット 60°) | | |

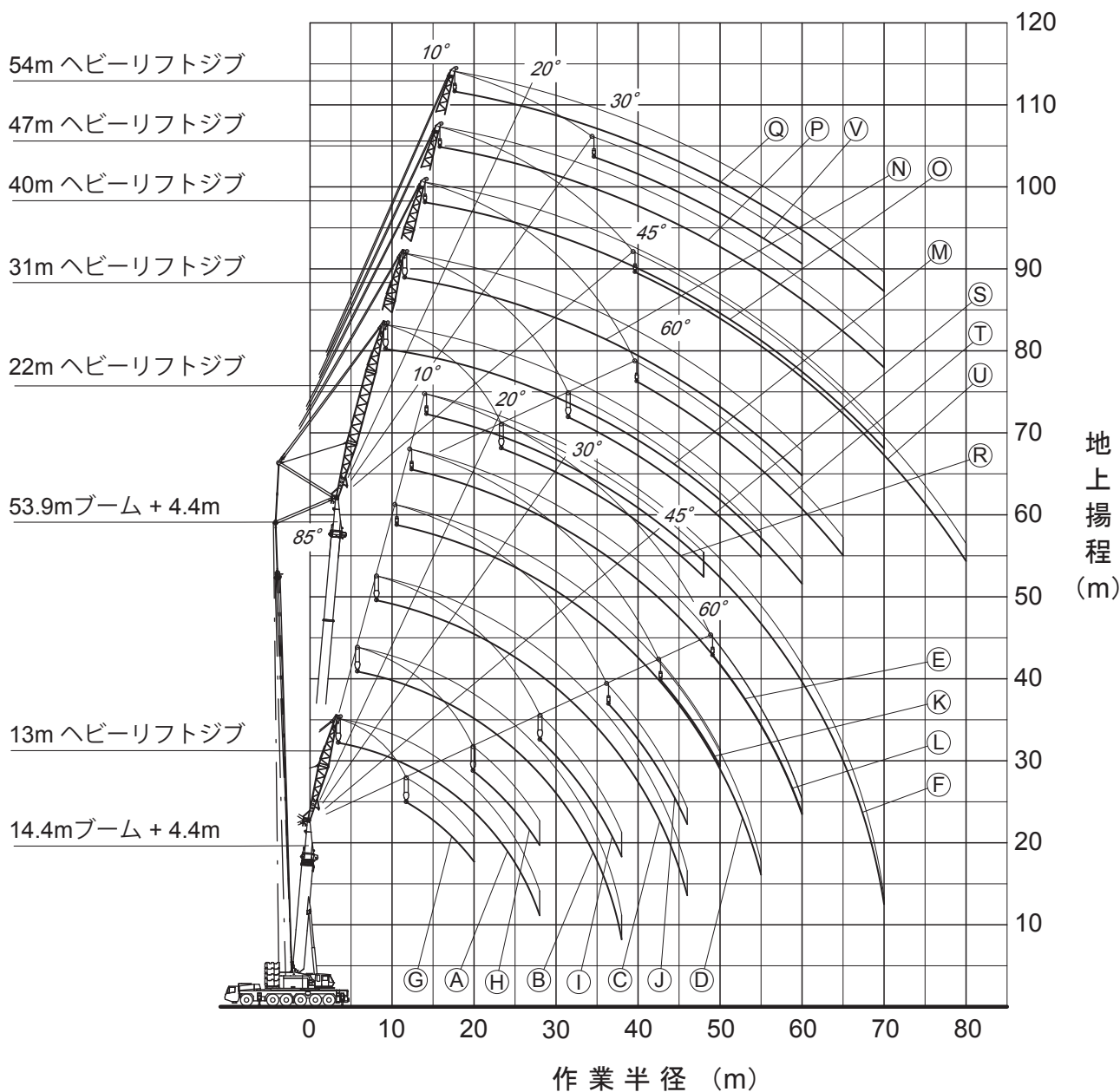

注1. 本図は、ブームおよびヘビーリフトジブのたわみを含んでいません。
 2. HA性能時のものを示してします。

HA性能 14.4mブーム+4.4m+13mヘビーリフトジブ

オフセット	10°	20°	30°	45°	60°
作業半径 (m)	荷重 (ton)	荷重 (ton)	荷重 (ton)	荷重 (ton)	荷重 (ton)
6.0	84.0				
7.0	84.0				
8.0	84.0	84.0			
9.0	84.0	80.7			
10.0	82.8	76.6	66.0		
11.0	78.3	72.9	63.4		
12.0	72.8	69.5	61.1	51.3	
14.0	63.4	63.8	56.9	48.5	34.6
16.0	56.1	56.5	53.4	46.2	33.7
18.0	50.2	50.7	50.3	44.4	33.1
20.0	45.1	45.8	46.3	42.9	32.9
22.0	40.2	40.8	41.3	41.8	
24.0	36.1	36.5	36.9	37.1	
26.0	32.6	32.9	33.1		
28.0	29.6	29.7			
危険角度 (°)	10	20	30	45	60
フック種類	150t	150t	150t	150t	150t
フック質量 (t)	1.90	1.90	1.90	1.90	1.90
掛数	8	8	8	8	8

HA性能 19.55mブーム+4.4m+13mヘビーリフトジブ

オフセット	10°	20°	30°	45°	60°
作業半径 (m)	荷重 (ton)	荷重 (ton)	荷重 (ton)	荷重 (ton)	荷重 (ton)
6.0	77.0				
7.0	77.0				
8.0	77.0	77.0			
9.0	77.0	77.0			
10.0	77.0	77.0	68.1		
11.0	77.0	76.1	65.7		
12.0	76.9	73.9	63.5		
14.0	65.1	66.7	59.5	50.8	37.7
16.0	56.0	57.3	56.2	48.6	36.8
18.0	48.7	49.8	50.9	46.8	36.1
20.0	42.8	43.7	44.6	45.2	35.6
22.0	37.8	38.7	39.4	40.2	35.4
24.0	33.7	34.4	35.0	35.6	
26.0	30.2	30.7	31.2	31.6	
28.0	27.1	27.5	27.9	28.1	
30.0	24.4	24.8	25.0		
32.0	22.0	22.2			
34.0	17.6				
危険角度 (°)	10	20	30	45	60
フック種類	150t	150t	150t	150t	150t
フック質量 (t)	1.90	1.90	1.90	1.90	1.90
掛数	8	8	8	8	8

HA性能 23.6mブーム+4.4m+13mヘビーリフトジブ

オフセット	10°	20°	30°	45°	60°
作業半径 (m)	荷重 (ton)	荷重 (ton)	荷重 (ton)	荷重 (ton)	荷重 (ton)
7.0	64.0				
8.0	64.0				
9.0	64.0	64.0			
10.0	64.0	64.0			
11.0	64.0	64.0	64.0		
12.0	64.0	64.0	64.0		
14.0	63.9	64.0	61.4	51.8	
16.0	54.8	56.3	57.7	49.9	38.8
18.0	47.5	48.8	50.0	48.2	38.1
20.0	41.5	42.7	43.7	45.0	37.5
22.0	36.6	37.6	38.5	39.5	37.2
24.0	32.4	33.3	34.0	34.8	35.2
26.0	28.8	29.6	30.2	30.8	
28.0	25.7	26.4	26.9	27.3	
30.0	23.0	23.6	23.9	24.2	
32.0	20.5	20.9	21.2		
34.0	18.3	18.6	18.7		
36.0	16.3	16.5			
38.0	12.5				
危険角度 (°)	10	20	30	45	60
フック種類	83t	83t	83t	83t	83t
フック質量 (t)	1.00	1.00	1.00	1.00	1.00
掛数	6	6	6	6	6

HA性能 32mブーム+4.4m+13mヘビーリフトジブ

オフセット	10°	20°	30°	45°	60°
作業半径 (m)	荷重 (ton)	荷重 (ton)	荷重 (ton)	荷重 (ton)	荷重 (ton)
8.0	45.0				
9.0	45.0				
10.0	45.0	40.4			
11.0	44.3	39.8			
12.0	43.6	39.3	35.6		
14.0	42.3	38.3	34.9	30.1	
16.0	41.2	37.5	34.2	29.7	25.5
18.0	40.2	36.8	33.7	29.4	25.4
20.0	39.4	36.2	33.2	29.2	25.3
22.0	36.4	35.7	32.9	29.0	25.3
24.0	32.2	33.2	32.7	29.0	25.3
26.0	28.7	29.5	30.3	29.0	25.3
28.0	25.6	26.3	27.0	27.7	25.3
30.0	22.8	23.5	24.1	24.7	
32.0	20.3	20.9	21.4	21.9	
34.0	18.0	18.6	19.0	19.4	
36.0	16.1	16.5	16.9	17.1	
38.0	14.3	14.7	14.9		
40.0	12.7	13.0	13.2		
42.0	11.3	11.5	11.5		
44.0	9.9	10.1			
46.0	7.6				
危険角度 (°)	10	20	30	45	60
フック種類	83t	83t	83t	83t	83t
フック質量 (t)	1.00	1.00	1.00	1.00	1.00
掛数	4	4	4	4	4

HB性能 14.4mブーム+4.4m+13mヘビーリフトジブ

オフセット	10°	20°	30°	45°	60°
作業半径 (m)	荷重 (ton)	荷重 (ton)	荷重 (ton)	荷重 (ton)	荷重 (ton)
6.0	84.0				
7.0	84.0				
8.0	84.0	84.0			
9.0	84.0	80.7			
10.0	82.8	76.6	66.0		
11.0	78.3	72.9	63.4		
12.0	72.8	69.5	61.1	51.3	
14.0	63.4	63.8	56.9	48.5	34.6
16.0	56.1	56.6	53.4	46.2	33.7
18.0	49.3	50.2	50.3	44.4	33.1
20.0	43.6	44.3	44.9	42.9	32.9
22.0	38.8	39.4	39.9	40.3	
24.0	34.7	35.2	35.6	35.8	
26.0	31.0	31.3	31.5		
28.0	27.9	28.0			
危険角度 (°)	10	20	30	45	60
フック種類	150t	150t	150t	150t	150t
フック質量 (t)	1.90	1.90	1.90	1.90	1.90
掛数	8	8	8	8	8

HB性能 19.55mブーム+4.4m+13mヘビーリフトジブ

オフセット	10°	20°	30°	45°	60°
作業半径 (m)	荷重 (ton)	荷重 (ton)	荷重 (ton)	荷重 (ton)	荷重 (ton)
6.0	77.0				
7.0	77.0				
8.0	77.0	77.0			
9.0	77.0	77.0			
10.0	77.0	77.0	68.1		
11.0	77.0	76.1	65.7		
12.0	74.4	73.9	63.5		
14.0	62.9	64.5	59.5	50.8	37.7
16.0	54.0	55.4	56.2	48.6	36.8
18.0	47.0	48.1	49.2	46.8	36.1
20.0	41.2	42.2	43.1	44.1	35.6
22.0	36.4	37.2	38.0	38.8	35.4
24.0	32.1	32.9	33.5	34.2	
26.0	28.4	29.0	29.5	30.0	
28.0	25.2	25.7	26.1	26.3	
30.0	22.5	22.8	23.0		
32.0	20.1	20.3			
34.0	17.6				
危険角度 (°)	10	20	30	45	60
フック種類	150t	150t	150t	150t	150t
フック質量 (t)	1.90	1.90	1.90	1.90	1.90
掛数	8	8	8	8	8

HB性能 23.6mブーム+4.4m+13mヘビーリフトジブ

オフセット	10°	20°	30°	45°	60°
作業半径 (m)	荷重 (ton)	荷重 (ton)	荷重 (ton)	荷重 (ton)	荷重 (ton)
7.0	64.0				
8.0	64.0				
9.0	64.0	64.0			
10.0	64.0	64.0			
11.0	64.0	64.0	64.0		
12.0	64.0	64.0	64.0		
14.0	61.8	63.6	61.4	51.8	
16.0	52.8	54.4	55.8	49.9	38.8
18.0	45.7	47.1	48.3	48.2	38.1
20.0	40.0	41.1	42.1	43.4	37.5
22.0	35.1	36.1	37.0	38.1	37.2
24.0	30.7	31.6	32.4	33.4	33.7
26.0	26.9	27.7	28.4	29.1	
28.0	23.7	24.4	25.0	25.5	
30.0	21.0	21.5	21.9	22.2	
32.0	18.6	19.0	19.3		
34.0	16.5	16.8	16.9		
36.0	14.6	14.8			
38.0	12.5				
危険角度 (°)	10	20	30	45	60
フック種類	83t	83t	83t	83t	83t
フック質量 (t)	1.00	1.00	1.00	1.00	1.00
掛数	6	6	6	6	6

HB性能 32mブーム+4.4m+13mヘビーリフトジブ

オフセット	10°	20°	30°	45°	60°
作業半径 (m)	荷重 (ton)	荷重 (ton)	荷重 (ton)	荷重 (ton)	荷重 (ton)
8.0	45.0				
9.0	45.0				
10.0	45.0	40.4			
11.0	44.3	39.8			
12.0	43.6	39.3	35.6		
14.0	42.3	38.3	34.8	30.1	
16.0	41.2	37.5	34.2	29.7	25.5
18.0	40.2	36.8	33.7	29.4	25.4
20.0	39.4	36.2	33.2	29.2	25.3
22.0	35.0	35.7	32.9	29.0	25.3
24.0	30.5	31.6	32.5	29.0	25.3
26.0	26.8	27.7	28.5	29.0	25.3
28.0	23.6	24.4	25.1	25.9	25.3
30.0	20.8	21.5	22.1	22.7	
32.0	18.4	19.0	19.5	20.0	
34.0	16.2	16.8	17.2	17.6	
36.0	14.4	14.8	15.2	15.4	
38.0	12.7	13.0	13.3		
40.0	11.2	11.5	11.6		
42.0	9.8	10.0	10.1		
44.0	8.6	8.7			
46.0	7.4				
危険角度 (°)	10	20	30	45	60
フック種類	83t	83t	83t	83t	83t
フック質量 (t)	1.00	1.00	1.00	1.00	1.00
掛数	4	4	4	4	4

HC性能 14.4mブーム+4.4m+13mヘビーリフトジブ

オフセット	10°	20°	30°	45°	60°
作業半径 (m)	荷重 (ton)	荷重 (ton)	荷重 (ton)	荷重 (ton)	荷重 (ton)
6.0	84.0				
7.0	84.0				
8.0	84.0	84.0			
9.0	84.0	80.7			
10.0	82.8	76.6	66.0		
11.0	78.3	72.9	63.4		
12.0	72.8	69.5	61.1	51.3	
14.0	63.0	63.8	56.9	48.5	34.6
16.0	54.4	55.5	53.4	46.2	33.7
18.0	47.6	48.4	49.2	44.4	33.1
20.0	41.4	42.2	42.9	42.9	32.9
22.0	36.4	37.0	37.5	38.0	
24.0	32.2	32.7	33.0	33.3	
26.0	28.7	29.0	29.2		
28.0	25.7	25.8			
危険角度 (°)	10	20	30	45	60
フック種類	150t	150t	150t	150t	150t
フック質量 (t)	1.90	1.90	1.90	1.90	1.90
掛数	8	8	8	8	8

HC性能 19.55mブーム+4.4m+13mヘビーリフトジブ

オフセット	10°	20°	30°	45°	60°
作業半径 (m)	荷重 (ton)	荷重 (ton)	荷重 (ton)	荷重 (ton)	荷重 (ton)
6.0	77.0				
7.0	77.0				
8.0	77.0	77.0			
9.0	77.0	77.0			
10.0	77.0	77.0	68.1		
11.0	77.0	76.1	65.7		
12.0	71.9	73.8	63.5		
14.0	60.8	62.4	59.5	50.8	37.7
16.0	52.1	53.5	54.7	48.6	36.8
18.0	45.0	46.3	47.5	46.8	36.1
20.0	38.8	39.9	40.8	42.0	35.6
22.0	33.7	34.6	35.4	36.4	35.4
24.0	29.5	30.3	30.9	31.6	
26.0	26.0	26.6	27.1	27.6	
28.0	23.0	23.5	23.9	24.1	
30.0	20.4	20.8	21.0		
32.0	18.2	18.4			
34.0	16.2				
危険角度 (°)	10	20	30	45	60
フック種類	150t	150t	150t	150t	150t
フック質量 (t)	1.90	1.90	1.90	1.90	1.90
掛数	8	8	8	8	8

HC性能 23.6mブーム+4.4m+13mヘビーリフトジブ

オフセット	10°	20°	30°	45°	60°
作業半径 (m)	荷重 (ton)	荷重 (ton)	荷重 (ton)	荷重 (ton)	荷重 (ton)
7.0	64.0				
8.0	64.0				
9.0	64.0	64.0			
10.0	64.0	64.0			
11.0	64.0	64.0	64.0		
12.0	64.0	64.0	64.0		
14.0	59.6	61.4	61.4	51.8	
16.0	50.9	52.5	53.9	49.9	38.8
18.0	43.6	45.1	46.5	48.1	38.1
20.0	37.4	38.7	39.8	41.3	37.5
22.0	32.3	33.4	34.4	35.6	36.2
24.0	28.1	29.1	29.9	30.8	31.2
26.0	24.6	25.4	26.1	26.8	
28.0	21.6	22.2	22.8	23.3	
30.0	18.9	19.5	19.9	20.2	
32.0	16.7	17.1	17.4		
34.0	14.7	15.0	15.1		
36.0	12.9	13.1			
38.0	11.3				
危険角度 (°)	10	20	30	45	60
フック種類	83t	83t	83t	83t	83t
フック質量 (t)	1.00	1.00	1.00	1.00	1.00
掛数	6	6	6	6	6

HC性能 32mブーム+4.4m+13mヘビーリフトジブ

オフセット	10°	20°	30°	45°	60°
作業半径 (m)	荷重 (ton)	荷重 (ton)	荷重 (ton)	荷重 (ton)	荷重 (ton)
8.0	45.0				
9.0	45.0				
10.0	45.0	40.4			
11.0	44.3	39.8			
12.0	43.6	39.3	35.6		
14.0	42.3	38.3	34.8	30.1	
16.0	41.2	37.5	34.2	29.7	25.5
18.0	40.2	36.8	33.7	29.4	25.4
20.0	37.2	36.2	33.2	29.2	25.3
22.0	32.2	33.4	32.9	29.0	25.3
24.0	28.0	29.0	30.0	29.0	25.3
26.0	24.4	25.3	26.2	27.1	25.3
28.0	21.4	22.2	22.9	23.7	24.0
30.0	18.8	19.5	20.1	20.7	
32.0	16.5	17.1	17.6	18.1	
34.0	14.4	15.0	15.4	15.8	
36.0	12.7	13.1	13.5	13.7	
38.0	11.1	11.4	11.7		
40.0	9.6	9.9	10.1		
42.0	8.3	8.6	8.6		
44.0	7.2	7.3			
46.0	6.1				
危険角度 (°)	10	20	30	45	60
フック種類	83t	83t	83t	83t	83t
フック質量 (t)	1.00	1.00	1.00	1.00	1.00
掛数	4	4	4	4	4

HD性能 14.4mブーム+4.4m+13mヘビーリフトジブ

オフセット	10°	20°	30°	45°	60°
作業半径 (m)	荷重 (ton)	荷重 (ton)	荷重 (ton)	荷重 (ton)	荷重 (ton)
6.0	84.0				
7.0	84.0				
8.0	84.0	84.0			
9.0	84.0	80.7			
10.0	82.8	76.6	66.0		
11.0	78.3	72.9	63.4		
12.0	71.7	69.5	61.1	51.3	
14.0	60.9	62.1	56.9	48.5	34.6
16.0	51.5	52.7	53.4	46.2	33.7
18.0	44.2	45.1	46.0	44.4	33.1
20.0	38.3	39.1	39.8	40.6	32.9
22.0	33.6	34.2	34.7	35.2	
24.0	29.6	30.1	30.4	30.7	
26.0	26.3	26.6	26.8		
28.0	23.5	23.6			
危険角度 (°)	10	20	30	45	60
フック種類	150t	150t	150t	150t	150t
フック質量 (t)	1.90	1.90	1.90	1.90	1.90
掛数	8	8	8	8	8

HD性能 19.55mブーム+4.4m+13mヘビーリフトジブ

オフセット	10°	20°	30°	45°	60°
作業半径 (m)	荷重 (ton)	荷重 (ton)	荷重 (ton)	荷重 (ton)	荷重 (ton)
6.0	77.0				
7.0	77.0				
8.0	77.0	77.0			
9.0	77.0	77.0			
10.0	77.0	77.0	68.1		
11.0	76.2	76.1	65.7		
12.0	69.5	71.3	63.5		
14.0	58.5	60.2	59.5	50.8	37.7
16.0	48.9	50.5	51.9	48.6	36.8
18.0	41.5	42.8	44.0	45.5	36.1
20.0	35.7	36.8	37.8	38.9	35.6
22.0	30.9	31.8	32.6	33.6	34.0
24.0	27.0	27.7	28.4	29.1	
26.0	23.6	24.3	24.8	25.2	
28.0	20.8	21.3	21.7	21.9	
30.0	18.4	18.7	19.0		
32.0	16.3	16.5			
34.0	14.4				
危険角度 (°)	10	20	30	45	60
フック種類	150t	150t	150t	150t	150t
フック質量 (t)	1.90	1.90	1.90	1.90	1.90
掛数	8	8	8	8	8

HD性能 23.6mブーム+4.4m+13mヘビーリフトジブ

オフセット	10°	20°	30°	45°	60°
作業半径 (m)	荷重 (ton)	荷重 (ton)	荷重 (ton)	荷重 (ton)	荷重 (ton)
7.0	64.0				
8.0	64.0				
9.0	64.0	64.0			
10.0	64.0	64.0			
11.0	64.0	64.0	64.0		
12.0	64.0	64.0	64.0		
14.0	57.2	59.3	61.0	51.8	
16.0	47.6	49.3	51.0	49.9	38.8
18.0	40.2	41.7	43.1	44.8	38.1
20.0	34.3	35.6	36.7	38.2	37.5
22.0	29.5	30.6	31.6	32.7	33.4
24.0	25.6	26.5	27.3	28.2	28.6
26.0	22.2	23.0	23.7	24.4	
28.0	19.4	20.0	20.6	21.1	
30.0	16.9	17.4	17.9	18.2	
32.0	14.7	15.2	15.5		
34.0	12.9	13.2	13.3		
36.0	11.2	11.4			
38.0	9.7				
危険角度 (°)	10	20	30	45	60
フック種類	83t	83t	83t	83t	83t
フック質量 (t)	1.00	1.00	1.00	1.00	1.00
掛数	6	6	6	6	6

HD性能 32mブーム+4.4m+13mヘビーリフトジブ

オフセット	10°	20°	30°	45°	60°
作業半径 (m)	荷重 (ton)	荷重 (ton)	荷重 (ton)	荷重 (ton)	荷重 (ton)
8.0	45.0				
9.0	45.0				
10.0	45.0	40.4			
11.0	44.3	39.8			
12.0	43.6	39.3	35.6		
14.0	42.3	38.3	34.8	30.1	
16.0	41.2	37.5	34.2	29.7	25.5
18.0	40.0	36.8	33.7	29.4	25.4
20.0	34.1	35.6	33.2	29.2	25.3
22.0	29.4	30.6	31.7	29.0	25.3
24.0	25.4	26.5	27.4	28.5	25.3
26.0	22.0	23.0	23.8	24.7	25.2
28.0	19.2	20.0	20.7	21.5	21.8
30.0	16.7	17.4	18.0	18.7	
32.0	14.5	15.2	15.7	16.2	
34.0	12.6	13.2	13.6	14.0	
36.0	11.0	11.4	11.8	12.0	
38.0	9.5	9.8	10.1		
40.0	8.1	8.4	8.6		
42.0	6.9	7.1	7.2		
44.0	5.8	5.9			
46.0	4.8				
危険角度 (°)	10	20	30	45	60
フック種類	83t	83t	83t	83t	83t
フック質量 (t)	1.00	1.00	1.00	1.00	1.00
掛数	4	4	4	4	4

HE性能 14.4mブーム+4.4m+13mヘビーリフトジブ

オフセット	10°	20°	30°	45°	60°
作業半径 (m)	荷重 (ton)	荷重 (ton)	荷重 (ton)	荷重 (ton)	荷重 (ton)
6.0	84.0				
7.0	84.0				
8.0	84.0	84.0			
9.0	84.0	80.7			
10.0	81.8	76.6	66.0		
11.0	73.6	72.9	63.4		
12.0	66.1	67.9	61.1	51.3	
14.0	54.4	55.8	56.9	48.5	34.6
16.0	45.7	46.9	47.9	46.2	33.7
18.0	39.0	39.9	40.8	41.9	33.1
20.0	33.7	34.4	35.1	35.9	32.9
22.0	29.3	29.9	30.5	31.0	
24.0	25.8	26.2	26.6	26.8	
26.0	22.7	23.1	23.3		
28.0	20.2	20.3			
危険角度 (°)	10	20	30	45	60
フック種類	150t	150t	150t	150t	150t
フック質量 (t)	1.90	1.90	1.90	1.90	1.90
掛数	8	8	8	8	8

HE性能 19.55mブーム+4.4m+13mヘビーリフトジブ

オフセット	10°	20°	30°	45°	60°
作業半径 (m)	荷重 (ton)	荷重 (ton)	荷重 (ton)	荷重 (ton)	荷重 (ton)
6.0	77.0				
7.0	77.0				
8.0	77.0	77.0			
9.0	77.0	77.0			
10.0	77.0	77.0	68.1		
11.0	71.0	73.6	65.7		
12.0	63.5	65.8	63.5		
14.0	51.8	53.6	55.4	50.8	37.7
16.0	43.1	44.6	46.0	47.9	36.8
18.0	36.4	37.7	38.8	40.3	36.1
20.0	31.0	32.1	33.1	34.3	35.0
22.0	26.7	27.6	28.4	29.3	29.8
24.0	23.1	23.9	24.5	25.2	
26.0	20.1	20.7	21.2	21.7	
28.0	17.5	18.0	18.4	18.6	
30.0	15.3	15.6	15.9		
32.0	13.4	13.6			
34.0	11.7				
危険角度 (°)	10	20	30	45	60
フック種類	150t	150t	150t	150t	150t
フック質量 (t)	1.90	1.90	1.90	1.90	1.90
掛数	8	8	8	8	8

HE性能 23.6mブーム+4.4m+13mヘビーリフトジブ

オフセット	10°	20°	30°	45°	60°
作業半径 (m)	荷重 (ton)	荷重 (ton)	荷重 (ton)	荷重 (ton)	荷重 (ton)
7.0	64.0				
8.0	64.0				
9.0	64.0	64.0			
10.0	64.0	64.0			
11.0	64.0	64.0	64.0		
12.0	62.2	64.0	64.0		
14.0	50.4	52.5	54.5	51.8	
16.0	41.7	43.5	45.1	47.2	38.8
18.0	35.0	36.5	37.9	39.6	38.1
20.0	29.6	30.9	32.1	33.5	34.4
22.0	25.3	26.4	27.4	28.5	29.1
24.0	21.7	22.6	23.4	24.4	24.7
26.0	18.7	19.5	20.1	20.8	
28.0	16.1	16.7	17.3	17.8	
30.0	13.8	14.4	14.8	15.1	
32.0	11.9	12.3	12.6		
34.0	10.2	10.5	10.6		
36.0	8.6	8.8			
38.0	7.3				
危険角度 (°)	10	20	30	45	60
フック種類	83t	83t	83t	83t	83t
フック質量 (t)	1.00	1.00	1.00	1.00	1.00
掛数	6	6	6	6	6

HE性能 32mブーム+4.4m+13mヘビーリフトジブ

オフセット	10°	20°	30°	45°	60°
作業半径 (m)	荷重 (ton)	荷重 (ton)	荷重 (ton)	荷重 (ton)	荷重 (ton)
8.0	45.0				
9.0	45.0				
10.0	45.0	40.4			
11.0	44.3	39.8			
12.0	43.6	39.3	35.6		
14.0	42.3	38.3	34.8	30.1	
16.0	41.2	37.5	34.2	29.7	25.5
18.0	34.8	36.5	33.7	29.4	25.4
20.0	29.5	30.9	32.2	29.2	25.3
22.0	25.1	26.4	27.5	28.8	25.3
24.0	21.5	22.6	23.6	24.7	25.3
26.0	18.5	19.4	20.2	21.2	21.6
28.0	15.9	16.7	17.4	18.2	18.5
30.0	13.6	14.1	15.0	15.6	
32.0	11.7	12.3	12.8	13.3	
34.0	9.9	10.5	10.9	11.2	
36.0	8.4	8.9	9.2	9.4	
38.0	7.0	7.4	7.7		
40.0	5.8	6.1	6.3		
42.0	4.7	4.9	5.0		
44.0	3.7	3.8			
危険角度 (°)	18	20	30	45	60
フック種類	83t	83t	83t	83t	83t
フック質量 (t)	1.00	1.00	1.00	1.00	1.00
掛数	4	4	4	4	4

HF性能 14.4mブーム+4.4m+13mヘビーリフトジブ

オフセット	10°	20°	30°	45°	60°
作業半径 (m)	荷重 (ton)	荷重 (ton)	荷重 (ton)	荷重 (ton)	荷重 (ton)
6.0	84.0				
7.0	84.0				
8.0	84.0	84.0			
9.0	84.0	80.7			
10.0	77.0	76.6	66.0		
11.0	68.4	70.4	63.4		
12.0	61.3	63.1	61.1	51.3	
14.0	50.3	51.7	53.1	48.5	34.6
16.0	42.1	43.3	44.4	45.8	33.7
18.0	35.8	36.8	37.7	38.7	33.1
20.0	30.8	31.6	32.3	33.1	32.9
22.0	26.8	27.4	27.9	28.4	
24.0	23.4	23.9	24.2	24.5	
26.0	20.6	20.9	21.1		
28.0	18.2	18.3			
危険角度 (°)	10	20	30	45	60
フック種類	150t	150t	150t	150t	150t
フック質量 (t)	1.90	1.90	1.90	1.90	1.90
掛数	8	8	8	8	8

HF性能 19.55mブーム+4.4m+13mヘビーリフトジブ

オフセット	10°	20°	30°	45°	60°
作業半径 (m)	荷重 (ton)	荷重 (ton)	荷重 (ton)	荷重 (ton)	荷重 (ton)
6.0	77.0				
7.0	77.0				
8.0	77.0	77.0			
9.0	77.0	77.0			
10.0	74.4	77.0	68.1		
11.0	65.8	68.3	65.7		
12.0	58.7	61.0	63.1		
14.0	47.7	49.5	51.3	50.8	37.7
16.0	39.5	41.1	42.5	44.3	36.8
18.0	33.2	34.5	35.7	37.2	36.1
20.0	28.2	29.3	30.3	31.5	32.2
22.0	24.1	25.1	25.9	26.8	27.2
24.0	20.8	21.5	22.2	22.9	
26.0	17.9	18.5	19.1	19.5	
28.0	15.5	16.0	16.4	16.6	
30.0	13.4	13.8	14.0		
32.0	11.6	11.8			
34.0	10.1				
危険角度 (°)	10	20	30	45	60
フック種類	150t	150t	150t	150t	150t
フック質量 (t)	1.90	1.90	1.90	1.90	1.90
掛数	8	8	8	8	8

HF性能 23.6mブーム+4.4m+13mヘビーリフトジブ

オフセット	10°	20°	30°	45°	60°
作業半径 (m)	荷重 (ton)	荷重 (ton)	荷重 (ton)	荷重 (ton)	荷重 (ton)
7.0	64.0				
8.0	64.0				
9.0	64.0	64.0			
10.0	64.0	64.0			
11.0	64.0	64.0	64.0		
12.0	57.4	60.0	62.4		
14.0	46.4	48.5	50.4	51.8	
16.0	38.2	39.9	41.6	43.7	38.8
18.0	31.8	33.3	34.7	36.5	37.6
20.0	26.8	28.1	29.3	30.7	31.6
22.0	22.7	23.8	24.8	26.0	26.6
24.0	19.4	20.3	21.1	22.0	22.4
26.0	16.5	17.3	18.0	18.7	
28.0	14.1	14.7	15.3	15.8	
30.0	12.0	12.5	12.9	13.2	
32.0	10.1	10.5	10.8		
34.0	8.5	8.8	9.0		
36.0	7.1	7.3			
38.0	5.8				
危険角度 (°)	10	20	30	45	60
フック種類	83t	83t	83t	83t	83t
フック質量 (t)	1.00	1.00	1.00	1.00	1.00
掛数	6	6	6	6	6

HF性能 32mブーム+4.4m+13mヘビーリフトジブ

オフセット	10°	20°	30°	45°	60°
作業半径 (m)	荷重 (ton)	荷重 (ton)	荷重 (ton)	荷重 (ton)	荷重 (ton)
8.0	45.0				
9.0	45.0				
10.0	45.0	40.4			
11.0	44.3	39.8			
12.0	43.6	39.3	35.6		
14.0	42.3	38.3	34.8	30.1	
16.0	38.0	37.5	34.2	29.7	25.5
18.0	31.7	33.3	33.7	29.4	25.4
20.0	26.7	28.1	29.4	29.2	25.3
22.0	22.6	23.8	24.9	26.2	25.3
24.0	19.2	20.3	21.2	22.3	23.0
26.0	16.3	17.3	18.1	19.0	19.5
28.0	13.9	14.7	15.4	16.2	16.5
30.0	11.8	12.5	13.1	13.7	
32.0	9.9	10.5	11.1	11.5	
34.0	8.3	8.8	9.3	9.6	
36.0	6.9	7.3	7.7	7.9	
38.0	5.6	5.9	6.2		
40.0	4.4	4.7	4.9		
42.0	3.4	3.6	3.7		
危険角度 (°)	26	27	30	45	60
フック種類	83t	83t	83t	83t	83t
フック質量 (t)	1.00	1.00	1.00	1.00	1.00
掛数	4	4	4	4	4

HG性能 14.4mブーム+4.4m+13mヘビーリフトジブ

オフセット	10°	20°	30°	45°	60°
作業半径 (m)	荷重 (ton)	荷重 (ton)	荷重 (ton)	荷重 (ton)	荷重 (ton)
6.0	84.0				
7.0	84.0				
8.0	84.0	84.0			
9.0	81.1	80.7			
10.0	71.2	73.4	66.0		
11.0	63.2	65.1	63.4		
12.0	56.5	58.3	60.0	51.3	
14.0	46.2	47.7	49.0	48.5	34.6
16.0	38.6	39.7	40.8	42.2	33.7
18.0	32.7	33.6	34.5	35.6	33.1
20.0	28.0	28.8	29.4	30.0	30.3
22.0	23.9	24.4	24.8	25.3	
24.0	20.5	20.9	21.2	21.4	
26.0	17.8	18.1	18.2		
28.0	15.6	15.7			
危険角度 (°)	10	20	30	45	60
フック種類	150t	150t	150t	150t	150t
フック質量 (t)	1.90	1.90	1.90	1.90	1.90
掛数	8	8	8	8	8

HG性能 19.55mブーム+4.4m+13mヘビーリフトジブ

オフセット	10°	20°	30°	45°	60°
作業半径 (m)	荷重 (ton)	荷重 (ton)	荷重 (ton)	荷重 (ton)	荷重 (ton)
6.0	77.0				
7.0	77.0				
8.0	77.0	77.0			
9.0	77.0	77.0			
10.0	68.6	71.4	68.1		
11.0	60.6	63.1	65.5		
12.0	53.9	56.2	58.3		
14.0	43.6	45.5	47.2	49.5	37.7
16.0	36.0	37.5	38.9	40.8	36.8
18.0	30.1	31.4	32.5	34.0	35.0
20.0	25.4	26.5	27.5	28.6	29.3
22.0	21.6	22.5	23.1	23.9	24.3
24.0	18.4	19.0	19.5	20.1	
26.0	15.7	16.2	16.6	17.0	
28.0	13.5	13.9	14.1	14.3	
30.0	11.6	11.9	12.1		
32.0	9.9	10.1			
34.0	8.4				
危険角度 (°)	10	20	30	45	60
フック種類	150t	150t	150t	150t	150t
フック質量 (t)	1.90	1.90	1.90	1.90	1.90
掛数	8	8	8	8	8

HG性能 23.6mブーム+4.4m+13mヘビーリフトジブ

オフセット	10°	20°	30°	45°	60°
作業半径 (m)	荷重 (ton)	荷重 (ton)	荷重 (ton)	荷重 (ton)	荷重 (ton)
7.0	64.0				
8.0	64.0				
9.0	64.0	64.0			
10.0	64.0	64.0			
11.0	59.2	62.1	64.0		
12.0	52.6	55.2	57.6		
14.0	42.3	44.4	46.4	48.9	
16.0	34.6	36.4	38.0	40.1	38.8
18.0	28.7	30.2	31.6	33.3	34.5
20.0	24.0	25.3	26.4	27.9	28.7
22.0	20.2	21.3	22.3	23.2	23.8
24.0	17.0	17.9	18.7	19.4	19.7
26.0	14.3	15.1	15.7	16.3	
28.0	12.1	12.7	13.3	13.7	
30.0	10.1	10.6	11.1	11.4	
32.0	8.4	8.8	9.1		
34.0	6.9	7.2	7.3		
36.0	5.5	5.7			
38.0	4.3				
危険角度 (°)	10	20	30	45	60
フック種類	83t	83t	83t	83t	83t
フック質量 (t)	1.00	1.00	1.00	1.00	1.00
掛数	6	6	6	6	6

HG性能 32mブーム+4.4m+13mヘビーリフトジブ

オフセット	10°	20°	30°	45°	60°
作業半径 (m)	荷重 (ton)	荷重 (ton)	荷重 (ton)	荷重 (ton)	荷重 (ton)
8.0	45.0				
9.0	45.0				
10.0	45.0	40.4			
11.0	44.3	39.8			
12.0	43.6	39.3	35.6		
14.0	42.2	38.3	34.8	30.1	
16.0	34.5	36.4	34.2	29.7	25.5
18.0	28.6	30.2	31.7	29.4	25.4
20.0	23.9	25.3	26.5	28.1	25.3
22.0	20.0	21.2	22.3	23.5	24.1
24.0	16.8	17.9	18.8	19.7	20.2
26.0	14.2	15.1	15.8	16.6	16.9
28.0	11.9	12.7	13.4	14.0	14.2
30.0	9.9	10.6	11.2	11.8	
32.0	8.2	8.8	9.3	9.8	
34.0	6.7	7.2	7.6	8.0	
36.0	5.3	5.8	6.1	6.3	
38.0	4.1	4.5	4.7		
40.0	3.0	3.3	3.5		
危険角度 (°)	32	33	34	45	60
フック種類	83t	83t	83t	83t	83t
フック質量 (t)	1.00	1.00	1.00	1.00	1.00
掛数	4	4	4	4	4

HA性能 14.4mブーム+4.4m+22mヘビーリフトジブ

オフセット	10°	20°	30°	45°	60°
作業半径 (m)	荷重 (ton)	荷重 (ton)	荷重 (ton)	荷重 (ton)	荷重 (ton)
8.0	54.0				
9.0	54.0				
10.0	54.0				
11.0	54.0				
12.0	54.0	52.8			
14.0	54.0	47.6			
16.0	50.5	43.4	38.0		
18.0	45.6	39.8	35.4		
20.0	41.6	36.8	33.1	28.2	
22.0	38.2	34.3	31.1	26.9	19.6
24.0	35.3	32.1	29.4	25.8	19.1
26.0	32.9	30.2	28.0	24.9	18.7
28.0	30.8	28.5	26.7	24.1	18.5
30.0	28.7	27.1	25.6	23.5	
32.0	26.4	25.9	24.8	23.1	
34.0	24.3	24.6	24.1		
36.0	22.4	22.6	22.8		
38.0	18.4				
危険角度 (°)	10	20	30	45	60
フック種類	83t	83t	83t	83t	83t
フック質量 (t)	1.00	1.00	1.00	1.00	1.00
掛数	6	6	6	6	6

HA性能 19.55mブーム+4.4m+22mヘビーリフトジブ

オフセット	10°	20°	30°	45°	60°
作業半径 (m)	荷重 (ton)	荷重 (ton)	荷重 (ton)	荷重 (ton)	荷重 (ton)
9.0	50.0				
10.0	50.0				
11.0	50.0				
12.0	50.0				
14.0	50.0	49.8			
16.0	50.0	45.7	39.1		
18.0	49.9	42.2	36.6		
20.0	45.2	39.2	34.4	29.4	
22.0	40.2	36.6	32.6	28.2	
24.0	36.0	34.4	30.9	27.1	20.9
26.0	32.4	32.4	29.4	26.2	20.5
28.0	29.3	30.3	28.2	25.4	20.2
30.0	26.6	27.5	27.0	24.7	20.0
32.0	24.2	25.0	25.7	24.2	20.0
34.0	22.1	22.7	23.3	23.8	
36.0	20.0	20.6	21.1	21.6	
38.0	18.2	18.7	19.1		
40.0	16.6	17.0	17.2		
42.0	15.2	15.4			
危険角度 (°)	10	20	30	45	60
フック種類	83t	83t	83t	83t	83t
フック質量 (t)	1.00	1.00	1.00	1.00	1.00
掛数	6	6	6	6	6

HA性能 23.6mブーム+4.4m+22mヘビーリフトジブ

オフセット	10°	20°	30°	45°	60°
作業半径 (m)	荷重 (ton)	荷重 (ton)	荷重 (ton)	荷重 (ton)	荷重 (ton)
10.0	45.0				
11.0	45.0				
12.0	45.0				
14.0	45.0	45.0			
16.0	45.0	45.0	42.2		
18.0	45.0	45.0	39.5		
20.0	44.2	43.3	37.3	31.2	
22.0	39.2	40.4	35.3	29.9	
24.0	34.9	36.4	33.5	28.8	22.2
26.0	31.3	32.6	31.9	27.9	21.7
28.0	28.2	29.4	30.5	27.0	21.4
30.0	25.4	26.5	27.5	26.3	21.1
32.0	23.0	24.0	24.8	25.6	21.0
34.0	20.8	21.7	22.4	23.3	21.0
36.0	18.7	19.5	20.2	20.9	
38.0	16.9	17.6	18.1	18.6	
40.0	15.3	15.8	16.3		
42.0	13.8	14.2	14.5		
44.0	12.5	12.8	12.9		
46.0	11.2	11.4			
危険角度 (°)	10	20	30	45	60
フック種類	83t	83t	83t	83t	83t
フック質量 (t)	1.00	1.00	1.00	1.00	1.00
掛数	4	4	4	4	4

HA性能 32mブーム+4.4m+22mヘビーリフトジブ

オフセット	10°	20°	30°	45°	60°
作業半径 (m)	荷重 (ton)	荷重 (ton)	荷重 (ton)	荷重 (ton)	荷重 (ton)
11.0	30.0				
12.0	30.0				
14.0	30.0	30.0			
16.0	30.0	29.4			
18.0	30.0	28.5	25.5		
20.0	30.0	27.6	24.8		
22.0	29.7	26.9	24.3	20.6	
24.0	28.8	26.2	23.8	20.2	16.9
26.0	28.1	25.6	23.3	19.9	16.7
28.0	27.4	25.1	22.9	19.7	16.6
30.0	24.7	24.7	22.6	19.5	16.6
32.0	22.3	23.4	22.3	19.4	16.6
34.0	20.1	21.1	22.1	19.3	16.6
36.0	18.0	19.0	19.9	19.3	16.6
38.0	16.2	17.1	17.8	18.7	16.6
40.0	14.6	15.4	16.0	16.7	
42.0	13.1	13.8	14.4	14.9	
44.0	11.8	12.4	12.9	13.3	
46.0	10.6	11.1	11.5		
48.0	9.5	9.9	10.2		
50.0	8.4	8.8	9.0		
55.0	5.3				
危険角度 (°)	10	20	30	45	60
フック種類	83t	83t	83t	83t	83t
フック質量 (t)	1.00	1.00	1.00	1.00	1.00
掛数	4	4	4	4	4

HA性能 40mブーム+4.4m+22mヘビーリフトジブ

オフセット	10°	20°	30°	45°	60°
作業半径 (m)	荷重 (ton)	荷重 (ton)	荷重 (ton)	荷重 (ton)	荷重 (ton)
12.0	20.0				
14.0	20.0				
16.0	20.0	20.0			
18.0	20.0	20.0			
20.0	20.0	20.0	20.0		
22.0	20.0	20.0	20.0		
24.0	20.0	20.0	20.0	18.4	
26.0	20.0	20.0	20.0	18.2	15.2
28.0	20.0	20.0	20.0	18.0	15.1
30.0	20.0	20.0	20.0	17.8	15.0
32.0	20.0	20.0	20.0	17.7	15.0
34.0	18.8	19.6	20.0	17.6	15.0
36.0	17.3	18.0	18.7	17.5	15.0
38.0	15.9	16.6	17.2	17.5	15.0
40.0	14.3	15.2	15.9	16.6	15.0
42.0	12.9	13.7	14.4	15.2	15.0
44.0	11.5	12.3	12.9	13.5	
46.0	10.3	11.0	11.5	12.0	
48.0	9.2	9.8	10.2	10.7	
50.0	8.1	8.6	9.1	9.4	
55.0	5.9	6.2	6.4		
60.0	4.0	4.1			
危険角度 (°)	15	20	30	45	60
フック種類	24t	24t	24t	24t	24t
フック質量 (t)	0.88	0.88	0.88	0.88	0.88
掛数	2	2	2	2	2

HA性能 45mブーム+4.4m+22mヘビーリフトジブ

オフセット	10°	20°	30°	45°	60°
作業半径 (m)	荷重 (ton)	荷重 (ton)	荷重 (ton)	荷重 (ton)	荷重 (ton)
12.0	16.0				
14.0	16.0				
16.0	16.0	16.0			
18.0	16.0	16.0			
20.0	16.0	16.0	16.0		
22.0	16.0	16.0	16.0		
24.0	16.0	16.0	16.0	16.0	
26.0	16.0	16.0	16.0	15.8	13.2
28.0	16.0	16.0	16.0	15.7	13.1
30.0	16.0	16.0	16.0	15.5	13.0
32.0	16.0	16.0	16.0	15.4	13.0
34.0	16.0	16.0	16.0	15.3	13.0
36.0	15.5	16.0	16.0	15.2	13.0
38.0	14.3	15.0	15.6	15.2	13.0
40.0	13.1	13.8	14.4	15.1	13.0
42.0	12.0	12.6	13.2	13.9	13.0
44.0	11.0	11.6	12.1	12.7	13.0
46.0	10.0	10.6	11.1	11.6	
48.0	8.9	9.6	10.1	10.6	
50.0	7.9	8.5	9.0	9.4	
55.0	5.6	6.1	6.4	6.6	
60.0	3.7	4.0	4.2		
危険角度 (°)	25	26	30	45	60
フック種類	24t	24t	24t	24t	24t
フック質量 (t)	0.88	0.88	0.88	0.88	0.88
掛数	2	2	2	2	2

HA性能 50mブーム+4.4m+22mヘビーリフトジブ

オフセット	10°	20°	30°	45°	60°
作業半径 (m)	荷重 (ton)	荷重 (ton)	荷重 (ton)	荷重 (ton)	荷重 (ton)
14.0	11.0				
16.0	11.0				
18.0	11.0	11.0			
20.0	11.0	11.0	11.0		
22.0	11.0	11.0	11.0		
24.0	11.0	11.0	11.0	9.5	
26.0	11.0	11.0	11.0	9.4	
28.0	11.0	11.0	11.0	9.3	7.6
30.0	11.0	11.0	11.0	9.2	7.6
32.0	11.0	11.0	10.9	9.2	7.6
34.0	11.0	11.0	10.8	9.1	7.6
36.0	11.0	11.0	10.7	9.1	7.6
38.0	11.0	11.0	10.6	9.1	7.6
40.0	11.0	11.0	10.6	9.1	7.6
42.0	10.2	10.8	10.5	9.1	7.6
44.0	9.3	9.9	10.3	9.1	7.6
46.0	8.5	9.0	9.5	9.1	7.6
48.0	7.8	8.3	8.7	9.1	
50.0	7.1	7.5	7.9	8.3	
55.0	5.4	5.9	6.2	6.5	
60.0	3.5	3.9	4.2		
危険角度 (°)	33	35	36	45	60
フック種類	24t	24t	24t	24t	24t
フック質量 (t)	0.88	0.88	0.88	0.88	0.88
掛数	2	2	2	2	2

HA性能 53.9mブーム+4.4m+22mヘビーリフトジブ

オフセット	10°	20°	30°	45°	60°
作業半径 (m)	荷重 (ton)	荷重 (ton)	荷重 (ton)	荷重 (ton)	荷重 (ton)
14.0	9.0				
16.0	9.0				
18.0	9.0	9.0			
20.0	9.0	9.0			
22.0	9.0	9.0	8.8		
24.0	9.0	9.0	8.6		
26.0	9.0	9.0	8.5	6.9	
28.0	9.0	9.0	8.3	6.9	5.5
30.0	9.0	9.0	8.2	6.8	5.5
32.0	9.0	9.0	8.1	6.8	5.5
34.0	9.0	9.0	8.1	6.7	5.5
36.0	9.0	9.0	8.0	6.7	5.5
38.0	9.0	8.9	8.0	6.7	5.5
40.0	9.0	8.8	7.9	6.7	5.5
42.0	8.7	8.8	7.9	6.7	5.5
44.0	7.9	8.5	7.9	6.7	5.5
46.0	7.2	7.7	7.9	6.7	5.5
48.0	6.5	6.9	7.4	6.7	5.5
50.0	5.8	6.3	6.7	6.7	
55.0	4.4	4.8	5.1	5.4	
60.0	3.2	3.5	3.7	3.9	
危険角度 (°)	38	40	41	45	60
フック種類	24t	24t	24t	24t	24t
フック質量 (t)	0.88	0.88	0.88	0.88	0.88
掛数	2	2	2	2	2

HB性能 14.4mブーム+4.4m+22mヘビーリフトジブ

オフセット	10°	20°	30°	45°	60°
作業半径 (m)	荷重 (ton)	荷重 (ton)	荷重 (ton)	荷重 (ton)	荷重 (ton)
8.0	54.0				
9.0	54.0				
10.0	54.0				
11.0	54.0				
12.0	54.0	52.8			
14.0	54.0	47.6			
16.0	50.5	43.4	38.0		
18.0	45.6	39.8	35.4		
20.0	41.6	36.8	33.1	28.2	
22.0	38.2	34.3	31.1	26.9	19.6
24.0	35.3	32.1	29.4	25.8	19.1
26.0	32.9	30.2	28.0	24.8	18.7
28.0	30.0	28.5	26.7	24.1	18.5
30.0	27.2	27.1	25.6	23.5	
32.0	24.7	25.3	24.8	23.1	
34.0	22.6	23.0	23.3		
36.0	20.7	21.0	21.1		
38.0	18.4				
危険角度 (°)	10	20	30	45	60
フック種類	83t	83t	83t	83t	83t
フック質量 (t)	1.00	1.00	1.00	1.00	1.00
掛数	6	6	6	6	6

HB性能 19.55mブーム+4.4m+22mヘビーリフトジブ

オフセット	10°	20°	30°	45°	60°
作業半径 (m)	荷重 (ton)	荷重 (ton)	荷重 (ton)	荷重 (ton)	荷重 (ton)
9.0	50.0				
10.0	50.0				
11.0	50.0				
12.0	50.0				
14.0	50.0	49.8			
16.0	50.0	45.7	39.1		
18.0	49.5	42.2	36.6		
20.0	43.6	39.2	34.4	29.4	
22.0	38.8	36.6	32.6	28.2	
24.0	34.7	34.4	30.9	27.1	20.9
26.0	30.9	32.1	29.4	26.2	20.5
28.0	27.7	28.7	28.2	25.4	20.2
30.0	24.9	25.8	26.7	24.7	20.0
32.0	22.4	23.2	24.0	24.2	20.0
34.0	20.3	20.9	21.6	22.3	
36.0	18.3	18.9	19.4	19.9	
38.0	16.6	17.1	17.5		
40.0	15.1	15.4	15.7		
42.0	13.7	13.9			
危険角度 (°)	10	20	30	45	60
フック種類	83t	83t	83t	83t	83t
フック質量 (t)	1.00	1.00	1.00	1.00	1.00
掛数	6	6	6	6	6

HB性能 23.6mブーム+4.4m+22mヘビーリフトジブ

オフセット	10°	20°	30°	45°	60°
作業半径 (m)	荷重 (ton)	荷重 (ton)	荷重 (ton)	荷重 (ton)	荷重 (ton)
10.0	45.0				
11.0	45.0				
12.0	45.0				
14.0	45.0	45.0			
16.0	45.0	45.0	42.2		
18.0	45.0	45.0	39.5		
20.0	42.6	43.3	37.3	31.2	
22.0	37.7	39.4	35.3	29.9	
24.0	33.5	35.1	33.5	28.8	22.2
26.0	29.7	31.2	31.9	27.9	21.7
28.0	26.4	27.7	28.9	27.0	21.4
30.0	23.6	24.8	25.8	26.3	21.1
32.0	21.1	22.2	23.1	24.2	21.0
34.0	19.0	19.9	20.7	21.6	21.0
36.0	17.0	17.8	18.5	19.2	
38.0	15.3	16.0	16.5	17.0	
40.0	13.8	14.3	14.7		
42.0	12.4	12.8	13.1		
44.0	11.1	11.4	11.5		
46.0	9.9	10.0			
危険角度 (°)	10	20	30	45	60
フック種類	83t	83t	83t	83t	83t
フック質量 (t)	1.00	1.00	1.00	1.00	1.00
掛数	4	4	4	4	4

HB性能 32mブーム+4.4m+22mヘビーリフトジブ

オフセット	10°	20°	30°	45°	60°
作業半径 (m)	荷重 (ton)	荷重 (ton)	荷重 (ton)	荷重 (ton)	荷重 (ton)
11.0	30.0				
12.0	30.0				
14.0	30.0	30.0			
16.0	30.0	29.4			
18.0	30.0	28.5	25.5		
20.0	30.0	27.6	24.8		
22.0	29.7	26.9	24.3	20.6	
24.0	28.8	26.2	23.8	20.2	16.9
26.0	28.1	25.6	23.3	19.9	16.7
28.0	25.7	25.1	22.9	19.7	16.6
30.0	22.9	24.2	22.6	19.5	16.6
32.0	20.4	21.6	22.3	19.4	16.6
34.0	18.3	19.3	20.3	19.3	16.6
36.0	16.3	17.3	18.2	19.2	16.6
38.0	14.6	15.5	16.2	17.1	16.6
40.0	13.1	13.8	14.5	15.2	
42.0	11.7	12.3	12.9	13.5	
44.0	10.4	11.0	11.5	11.9	
46.0	9.2	9.7	10.1		
48.0	8.2	8.6	8.9		
50.0	7.2	7.5	7.7		
55.0	5.1				
危険角度 (°)	10	20	30	45	60
フック種類	83t	83t	83t	83t	83t
フック質量 (t)	1.00	1.00	1.00	1.00	1.00
掛数	4	4	4	4	4

HB性能 40mブーム+4.4m+22mヘビーリフトジブ

オフセット	10°	20°	30°	45°	60°
作業半径 (m)	荷重 (ton)	荷重 (ton)	荷重 (ton)	荷重 (ton)	荷重 (ton)
12.0	20.0				
14.0	20.0				
16.0	20.0	20.0			
18.0	20.0	20.0			
20.0	20.0	20.0	20.0		
22.0	20.0	20.0	20.0		
24.0	20.0	20.0	20.0	18.4	
26.0	20.0	20.0	20.0	18.2	15.2
28.0	20.0	20.0	20.0	18.0	15.1
30.0	20.0	20.0	20.0	17.8	15.0
32.0	20.0	20.0	20.0	17.7	15.0
34.0	18.0	19.2	20.0	17.6	15.0
36.0	16.1	17.2	18.2	17.5	15.0
38.0	14.4	15.4	16.2	17.3	15.0
40.0	12.8	13.7	14.5	15.4	15.0
42.0	11.4	12.2	12.9	13.7	14.0
44.0	10.1	10.9	11.5	12.2	
46.0	9.0	9.6	10.2	10.7	
48.0	7.9	8.5	9.0	9.4	
50.0	6.9	7.4	7.8	8.1	
55.0	4.8	5.1	5.3		
60.0	3.0	3.1			
危険角度 (°)	19	20	30	45	60
フック種類	24t	24t	24t	24t	24t
フック質量 (t)	0.88	0.88	0.88	0.88	0.88
掛数	2	2	2	2	2

HB性能 45mブーム+4.4m+22mヘビーリフトジブ

オフセット	10°	20°	30°	45°	60°
作業半径 (m)	荷重 (ton)	荷重 (ton)	荷重 (ton)	荷重 (ton)	荷重 (ton)
12.0	16.0				
14.0	16.0				
16.0	16.0	16.0			
18.0	16.0	16.0			
20.0	16.0	16.0	16.0		
22.0	16.0	16.0	16.0		
24.0	16.0	16.0	16.0	16.0	
26.0	16.0	16.0	16.0	15.8	13.2
28.0	16.0	16.0	16.0	15.7	13.1
30.0	16.0	16.0	16.0	15.5	13.0
32.0	16.0	16.0	16.0	15.4	13.0
34.0	16.0	16.0	16.0	15.3	13.0
36.0	15.5	16.0	16.0	15.2	13.0
38.0	14.1	15.0	15.6	15.2	13.0
40.0	12.5	13.5	14.4	15.1	13.0
42.0	11.1	12.0	12.8	13.7	13.0
44.0	9.9	10.7	11.4	12.1	12.4
46.0	8.7	9.4	10.1	10.7	
48.0	7.6	8.3	8.9	9.4	
50.0	6.6	7.2	7.7	8.2	
55.0	4.5	5.0	5.3	5.5	
60.0	2.7	3.0	3.2		
危険角度 (°)	27	28	30	45	60
フック種類	24t	24t	24t	24t	24t
フック質量 (t)	0.88	0.88	0.88	0.88	0.88
掛数	2	2	2	2	2

HB性能 50mブーム+4.4m+22mヘビーリフトジブ

オフセット	10°	20°	30°	45°	60°
作業半径 (m)	荷重 (ton)	荷重 (ton)	荷重 (ton)	荷重 (ton)	荷重 (ton)
14.0	11.0				
16.0	11.0				
18.0	11.0	11.0			
20.0	11.0	11.0	11.0		
22.0	11.0	11.0	11.0		
24.0	11.0	11.0	11.0	9.5	
26.0	11.0	11.0	11.0	9.4	
28.0	11.0	11.0	11.0	9.3	7.6
30.0	11.0	11.0	11.0	9.2	7.6
32.0	11.0	11.0	10.9	9.2	7.6
34.0	11.0	11.0	10.8	9.1	7.6
36.0	11.0	11.0	10.7	9.1	7.6
38.0	11.0	11.0	10.6	9.1	7.6
40.0	11.0	11.0	10.6	9.1	7.6
42.0	10.2	10.8	10.5	9.1	7.6
44.0	9.3	9.9	10.3	9.1	7.6
46.0	8.4	9.0	9.5	9.1	7.6
48.0	7.4	8.1	8.7	9.1	
50.0	6.4	7.1	7.6	8.2	
55.0	4.3	4.8	5.2	5.5	
60.0		2.9	3.2		
危険角度 (°)	40	40	40	45	60
フック種類	24t	24t	24t	24t	24t
フック質量 (t)	0.88	0.88	0.88	0.88	0.88
掛数	2	2	2	2	2

HB性能 53.9mブーム+4.4m+22mヘビーリフトジブ

オフセット	10°	20°	30°	45°	60°
作業半径 (m)	荷重 (ton)	荷重 (ton)	荷重 (ton)	荷重 (ton)	荷重 (ton)
14.0	9.0				
16.0	9.0				
18.0	9.0	9.0			
20.0	9.0	9.0			
22.0	9.0	9.0	8.8		
24.0	9.0	9.0	8.6		
26.0	9.0	9.0	8.5	6.9	
28.0	9.0	9.0	8.3	6.9	5.5
30.0	9.0	9.0	8.2	6.8	5.5
32.0	9.0	9.0	8.1	6.8	5.5
34.0	9.0	9.0	8.1	6.7	5.5
36.0	9.0	9.0	8.0	6.7	5.5
38.0	9.0	8.9	8.0	6.7	5.5
40.0	9.0	8.8	7.9	6.7	5.5
42.0	8.7	8.8	7.9	6.7	5.5
44.0	7.9	8.5	7.9	6.7	5.5
46.0	7.2	7.7	7.9	6.7	5.5
48.0	6.5	6.9	7.4	6.7	5.5
50.0	5.8	6.3	6.7	6.7	
55.0	4.1	4.6	5.1	5.4	
60.0		2.7	3.1	3.3	
危険角度 (°)	44	44	44	45	60
フック種類	24t	24t	24t	24t	24t
フック質量 (t)	0.88	0.88	0.88	0.88	0.88
掛数	2	2	2	2	2

HC性能 14.4mブーム+4.4m+22mヘビーリフトジブ

オフセット	10°	20°	30°	45°	60°
作業半径 (m)	荷重 (ton)	荷重 (ton)	荷重 (ton)	荷重 (ton)	荷重 (ton)
8.0	54.0				
9.0	54.0				
10.0	54.0				
11.0	54.0				
12.0	54.0	52.8			
14.0	54.0	47.6			
16.0	50.5	43.4	38.0		
18.0	45.6	39.8	35.4		
20.0	41.6	36.8	33.1	28.2	
22.0	38.2	34.3	31.1	26.9	19.6
24.0	34.4	32.1	29.4	25.8	19.1
26.0	30.8	30.2	28.0	24.8	18.7
28.0	27.8	28.5	26.7	24.1	18.5
30.0	25.1	25.8	25.6	23.5	
32.0	22.8	23.3	23.8	23.1	
34.0	20.8	21.2	21.5		
36.0	19.0	19.3	19.4		
38.0	17.4				
危険角度 (°)	10	20	30	45	60
フック種類	83t	83t	83t	83t	83t
フック質量 (t)	1.00	1.00	1.00	1.00	1.00
掛数	6	6	6	6	6

HC性能 19.55mブーム+4.4m+22mヘビーリフトジブ

オフセット	10°	20°	30°	45°	60°
作業半径 (m)	荷重 (ton)	荷重 (ton)	荷重 (ton)	荷重 (ton)	荷重 (ton)
9.0	50.0				
10.0	50.0				
11.0	50.0				
12.0	50.0				
14.0	50.0	49.8			
16.0	50.0	45.7	39.1		
18.0	47.8	42.2	36.6		
20.0	41.6	39.2	34.4	29.4	
22.0	36.4	36.6	32.6	28.2	
24.0	32.2	33.6	30.9	27.1	20.9
26.0	28.6	29.8	29.4	26.2	20.5
28.0	25.5	26.6	27.6	25.4	20.2
30.0	22.8	23.8	24.9	24.7	20.0
32.0	20.5	21.3	22.1	23.0	20.0
34.0	18.5	19.2	19.8	20.5	
36.0	16.6	17.2	17.7	18.2	
38.0	15.0	15.5	15.9		
40.0	13.6	13.9	14.1		
42.0	12.3	12.5			
危険角度 (°)	10	20	30	45	60
フック種類	83t	83t	83t	83t	83t
フック質量 (t)	1.00	1.00	1.00	1.00	1.00
掛数	6	6	6	6	6

HC性能 23.6mブーム+4.4m+22mヘビーリフトジブ

オフセット	10°	20°	30°	45°	60°
作業半径 (m)	荷重 (ton)	荷重 (ton)	荷重 (ton)	荷重 (ton)	荷重 (ton)
10.0	45.0				
11.0	45.0				
12.0	45.0				
14.0	45.0	45.0			
16.0	45.0	45.0	42.2		
18.0	45.0	45.0	39.5		
20.0	40.5	42.6	37.3	31.2	
22.0	35.3	37.1	35.3	29.9	
24.0	31.0	32.6	33.5	28.8	22.2
26.0	27.4	28.8	30.2	27.9	21.7
28.0	24.3	25.6	26.8	27.0	21.4
30.0	21.6	22.7	23.8	25.1	21.1
32.0	19.2	20.2	21.2	22.3	21.0
34.0	17.2	18.1	18.9	19.8	20.2
36.0	15.3	16.1	16.8	17.5	
38.0	13.7	14.4	14.9	15.4	
40.0	12.2	12.8	13.2		
42.0	10.9	11.3	11.6		
44.0	9.7	10.0	10.1		
46.0	8.6	8.7			
危険角度 (°)	10	20	30	45	60
フック種類	83t	83t	83t	83t	83t
フック質量 (t)	1.00	1.00	1.00	1.00	1.00
掛数	4	4	4	4	4

HC性能 32mブーム+4.4m+22mヘビーリフトジブ

オフセット	10°	20°	30°	45°	60°
作業半径 (m)	荷重 (ton)	荷重 (ton)	荷重 (ton)	荷重 (ton)	荷重 (ton)
11.0	30.0				
12.0	30.0				
14.0	30.0	30.0			
16.0	30.0	29.4			
18.0	30.0	28.5	25.5		
20.0	30.0	27.6	24.8		
22.0	29.7	26.9	24.3	20.6	
24.0	28.8	26.2	23.8	20.2	16.9
26.0	26.6	25.6	23.3	19.9	16.7
28.0	23.5	25.0	22.9	19.7	16.6
30.0	20.9	22.2	22.6	19.5	16.6
32.0	18.5	19.7	20.8	19.4	16.6
34.0	16.5	17.5	18.5	19.3	16.6
36.0	14.6	15.6	16.5	17.5	16.6
38.0	13.0	13.9	14.6	15.5	15.8
40.0	11.5	12.3	13.0	13.7	
42.0	10.2	10.9	11.5	12.0	
44.0	9.0	9.6	10.1	10.5	
46.0	7.9	8.4	8.8		
48.0	6.9	7.3	7.6		
50.0	6.0	6.3	6.5		
55.0	4.0				
危険角度 (°)	10	20	30	45	60
フック種類	83t	83t	83t	83t	83t
フック質量 (t)	1.00	1.00	1.00	1.00	1.00
掛数	4	4	4	4	4

HC性能 40mブーム+4.4m+22mヘビーリフトジブ

オフセット	10°	20°	30°	45°	60°
作業半径 (m)	荷重 (ton)	荷重 (ton)	荷重 (ton)	荷重 (ton)	荷重 (ton)
12.0	20.0				
14.0	20.0				
16.0	20.0	20.0			
18.0	20.0	20.0			
20.0	20.0	20.0	20.0		
22.0	20.0	20.0	20.0		
24.0	20.0	20.0	20.0	18.4	
26.0	20.0	20.0	20.0	18.2	15.2
28.0	20.0	20.0	20.0	18.0	15.1
30.0	20.0	20.0	20.0	17.8	15.0
32.0	18.3	19.6	20.0	17.7	15.0
34.0	16.2	17.4	18.5	17.6	15.0
36.0	14.4	15.5	16.5	17.5	15.0
38.0	12.8	13.8	14.6	15.7	15.0
40.0	11.3	12.2	13.0	13.9	14.3
42.0	10.0	10.8	11.5	12.3	12.5
44.0	8.7	9.5	10.1	10.8	
46.0	7.6	8.3	8.9	9.4	
48.0	6.6	7.2	7.7	8.1	
50.0	5.7	6.2	6.6	6.9	
55.0	3.7	4.0	4.2		
危険角度 (°)	26	27	30	45	60
フック種類	24t	24t	24t	24t	24t
フック質量 (t)	0.88	0.88	0.88	0.88	0.88
掛数	2	2	2	2	2

HC性能 45mブーム+4.4m+22mヘビーリフトジブ

オフセット	10°	20°	30°	45°	60°
作業半径 (m)	荷重 (ton)	荷重 (ton)	荷重 (ton)	荷重 (ton)	荷重 (ton)
12.0	16.0				
14.0	16.0				
16.0	16.0	16.0			
18.0	16.0	16.0			
20.0	16.0	16.0	16.0		
22.0	16.0	16.0	16.0		
24.0	16.0	16.0	16.0	16.0	
26.0	16.0	16.0	16.0	15.8	13.2
28.0	16.0	16.0	16.0	15.7	13.1
30.0	16.0	16.0	16.0	15.5	13.0
32.0	16.0	16.0	16.0	15.4	13.0
34.0	16.0	16.0	16.0	15.3	13.0
36.0	14.1	15.3	16.0	15.2	13.0
38.0	12.5	13.5	14.5	15.2	13.0
40.0	11.0	12.0	12.8	13.8	13.0
42.0	9.7	10.6	11.3	12.2	12.6
44.0	8.5	9.3	10.0	10.8	11.0
46.0	7.4	8.1	8.7	9.4	
48.0	6.4	7.0	7.6	8.1	
50.0	5.4	6.0	6.5	7.0	
55.0	3.4	3.8	4.2	4.4	
危険角度 (°)	38	40	42	45	60
フック種類	24t	24t	24t	24t	24t
フック質量 (t)	0.88	0.88	0.88	0.88	0.88
掛数	2	2	2	2	2

HC性能 50mブーム+4.4m+22mヘビーリフトジブ

オフセット	10°	20°	30°	45°	60°
作業半径 (m)	荷重 (ton)	荷重 (ton)	荷重 (ton)	荷重 (ton)	荷重 (ton)
14.0	11.0				
16.0	11.0				
18.0	11.0	11.0			
20.0	11.0	11.0	11.0		
22.0	11.0	11.0	11.0		
24.0	11.0	11.0	11.0	9.5	
26.0	11.0	11.0	11.0	9.4	
28.0	11.0	11.0	11.0	9.3	7.6
30.0	11.0	11.0	11.0	9.2	7.6
32.0	11.0	11.0	10.9	9.2	7.6
34.0	11.0	11.0	10.8	9.1	7.6
36.0	11.0	11.0	10.7	9.1	7.6
38.0	11.0	11.0	10.6	9.1	7.6
40.0	10.8	11.0	10.6	9.1	7.6
42.0	9.4	10.4	10.5	9.1	7.6
44.0	8.2	9.1	9.8	9.1	7.6
46.0	7.1	7.9	8.6	9.1	7.6
48.0	6.1	6.8	7.5	8.1	
50.0	5.2	5.8	6.4	7.0	
55.0	3.1	3.7	4.1	4.4	
危険角度 (°)	42	44	46	48	60
フック種類	24t	24t	24t	24t	24t
フック質量 (t)	0.88	0.88	0.88	0.88	0.88
掛数	2	2	2	2	2

HC性能 53.9mブーム+4.4m+22mヘビーリフトジブ

オフセット	10°	20°	30°	45°	60°
作業半径 (m)	荷重 (ton)	荷重 (ton)	荷重 (ton)	荷重 (ton)	荷重 (ton)
14.0	9.0				
16.0	9.0				
18.0	9.0	9.0			
20.0	9.0	9.0			
22.0	9.0	9.0	8.8		
24.0	9.0	9.0	8.6		
26.0	9.0	9.0	8.5	6.9	
28.0	9.0	9.0	8.3	6.9	5.5
30.0	9.0	9.0	8.2	6.8	5.5
32.0	9.0	9.0	8.1	6.8	5.5
34.0	9.0	9.0	8.1	6.7	5.5
36.0	9.0	9.0	8.0	6.7	5.5
38.0	9.0	8.9	8.0	6.7	5.5
40.0	9.0	8.8	7.9	6.7	5.5
42.0	8.7	8.8	7.9	6.7	5.5
44.0	7.9	8.5	7.9	6.7	5.5
46.0	6.9	7.7	7.9	6.7	5.5
48.0	5.9	6.7	7.4	6.7	5.5
50.0	5.0	5.7	6.3	6.7	
55.0	3.0	3.5	4.0	4.5	
危険角度 (°)	45	47	48	49	60
フック種類	24t	24t	24t	24t	24t
フック質量 (t)	0.88	0.88	0.88	0.88	0.88
掛数	2	2	2	2	2

HD性能 14.4mブーム+4.4m+22mヘビーリフトジブ

オフセット	10°	20°	30°	45°	60°
作業半径 (m)	荷重 (ton)	荷重 (ton)	荷重 (ton)	荷重 (ton)	荷重 (ton)
8.0	54.0				
9.0	54.0				
10.0	54.0				
11.0	54.0				
12.0	54.0	52.8			
14.0	54.0	47.6			
16.0	50.5	43.4	38.0		
18.0	45.6	39.8	35.4		
20.0	40.7	36.8	33.1	28.2	
22.0	35.9	34.3	31.1	26.9	19.6
24.0	31.9	32.1	29.4	25.8	19.1
26.0	28.5	29.4	28.0	24.8	18.7
28.0	25.6	26.3	26.7	24.1	18.5
30.0	23.1	23.7	24.3	23.5	
32.0	20.9	21.4	21.9	22.4	
34.0	19.0	19.4	19.7		
36.0	17.3	17.6	17.7		
38.0	15.8				
危険角度 (°)	10	20	30	45	60
フック種類	83t	83t	83t	83t	83t
フック質量 (t)	1.00	1.00	1.00	1.00	1.00
掛数	6	6	6	6	6

HD性能 19.55mブーム+4.4m+22mヘビーリフトジブ

オフセット	10°	20°	30°	45°	60°
作業半径 (m)	荷重 (ton)	荷重 (ton)	荷重 (ton)	荷重 (ton)	荷重 (ton)
9.0	50.0				
10.0	50.0				
11.0	50.0				
12.0	50.0				
14.0	50.0	49.8			
16.0	50.0	45.7	39.1		
18.0	44.5	42.2	36.6		
20.0	38.5	39.2	34.4	29.4	
22.0	33.6	35.2	32.6	28.2	
24.0	29.6	31.0	30.9	27.1	20.9
26.0	26.2	27.4	28.6	26.2	20.5
28.0	23.3	24.4	25.4	25.4	20.2
30.0	20.8	21.7	22.6	23.7	20.0
32.0	18.6	19.4	20.1	21.0	20.0
34.0	16.7	17.4	18.0	18.7	
36.0	14.9	15.5	16.0	16.5	
38.0	13.4	13.9	14.3		
40.0	12.1	12.4	12.6		
42.0	10.8	11.0			
危険角度 (°)	10	20	30	45	60
フック種類	83t	83t	83t	83t	83t
フック質量 (t)	1.00	1.00	1.00	1.00	1.00
掛数	6	6	6	6	6

HD性能 23.6mブーム+4.4m+22mヘビーリフトジブ

オフセット	10°	20°	30°	45°	60°
作業半径 (m)	荷重 (ton)	荷重 (ton)	荷重 (ton)	荷重 (ton)	荷重 (ton)
10.0	45.0				
11.0	45.0				
12.0	45.0				
14.0	45.0	45.0			
16.0	45.0	45.0	42.2		
18.0	43.4	45.0	39.5		
20.0	37.4	39.5	37.3	31.2	
22.0	32.5	34.3	35.3	29.9	
24.0	28.4	30.1	31.6	28.8	22.2
26.0	25.0	26.4	27.8	27.9	21.7
28.0	22.1	23.4	24.6	26.1	21.4
30.0	19.5	20.7	21.7	23.1	21.1
32.0	17.3	18.3	19.3	20.4	21.0
34.0	15.4	16.3	17.1	18.0	18.4
36.0	13.6	14.4	15.1	15.8	
38.0	12.1	12.8	13.3	13.8	
40.0	10.7	11.3	11.7		
42.0	9.5	9.9	10.2		
44.0	8.3	8.6	8.8		
46.0	7.3	7.4			
危険角度 (°)	10	20	30	45	60
フック種類	83t	83t	83t	83t	83t
フック質量 (t)	1.00	1.00	1.00	1.00	1.00
掛数	4	4	4	4	4

HD性能 32mブーム+4.4m+22mヘビーリフトジブ

オフセット	10°	20°	30°	45°	60°
作業半径 (m)	荷重 (ton)	荷重 (ton)	荷重 (ton)	荷重 (ton)	荷重 (ton)
11.0	30.0				
12.0	30.0				
14.0	30.0	30.0			
16.0	30.0	29.4			
18.0	30.0	28.5	25.5		
20.0	30.0	27.6	24.8		
22.0	29.7	26.9	24.3	20.6	
24.0	27.7	26.2	23.8	20.2	16.9
26.0	24.3	25.6	23.3	19.9	16.7
28.0	21.3	22.8	22.9	19.7	16.6
30.0	18.8	20.1	21.3	19.5	16.6
32.0	16.6	17.8	18.9	19.4	16.6
34.0	14.7	15.7	16.7	17.9	16.6
36.0	12.9	13.9	14.8	15.8	16.3
38.0	11.4	12.3	13.0	13.9	14.2
40.0	10.0	10.8	11.4	12.2	
42.0	8.8	9.4	10.0	10.6	
44.0	7.6	8.2	8.7	9.1	
46.0	6.6	7.1	7.5		
48.0	5.6	6.1	6.4		
50.0	4.8	5.1	5.3		
危険角度 (°)	18	20	30	45	60
フック種類	83t	83t	83t	83t	83t
フック質量 (t)	1.00	1.00	1.00	1.00	1.00
掛数	4	4	4	4	4

HD性能 40mブーム+4.4m+22mヘビーリフトジブ

オフセット	10°	20°	30°	45°	60°
作業半径 (m)	荷重 (ton)	荷重 (ton)	荷重 (ton)	荷重 (ton)	荷重 (ton)
12.0	20.0				
14.0	20.0				
16.0	20.0	20.0			
18.0	20.0	20.0			
20.0	20.0	20.0	20.0		
22.0	20.0	20.0	20.0		
24.0	20.0	20.0	20.0	18.4	
26.0	20.0	20.0	20.0	18.2	15.2
28.0	20.0	20.0	20.0	18.0	15.1
30.0	18.6	20.0	20.0	17.8	15.0
32.0	16.4	17.7	18.9	17.7	15.0
34.0	14.4	15.6	16.7	17.6	15.0
36.0	12.7	13.8	14.8	15.9	15.0
38.0	11.2	12.1	13.0	14.1	14.6
40.0	9.8	10.7	11.5	12.4	12.8
42.0	8.5	9.3	10.0	10.8	11.1
44.0	7.4	8.1	8.7	9.4	
46.0	6.3	7.0	7.5	8.1	
48.0	5.4	5.9	6.4	6.8	
50.0	4.5	5.0	5.4	5.7	
55.0		2.9	3.1		
危険角度 (°)	36	36	36	45	60
フック種類	24t	24t	24t	24t	24t
フック質量 (t)	0.88	0.88	0.88	0.88	0.88
掛数	2	2	2	2	2

HD性能 45mブーム+4.4m+22mヘビーリフトジブ

オフセット	10°	20°	30°	45°	60°
作業半径 (m)	荷重 (ton)	荷重 (ton)	荷重 (ton)	荷重 (ton)	荷重 (ton)
12.0	16.0				
14.0	16.0				
16.0	16.0	16.0			
18.0	16.0	16.0			
20.0	16.0	16.0	16.0		
22.0	16.0	16.0	16.0		
24.0	16.0	16.0	16.0	16.0	
26.0	16.0	16.0	16.0	15.8	13.2
28.0	16.0	16.0	16.0	15.7	13.1
30.0	16.0	16.0	16.0	15.5	13.0
32.0	16.0	16.0	16.0	15.4	13.0
34.0	14.2	15.4	16.0	15.3	13.0
36.0	12.4	13.6	14.6	15.2	13.0
38.0	10.9	11.9	12.9	14.0	13.0
40.0	9.5	10.5	11.3	12.3	12.8
42.0	8.2	9.1	9.9	10.8	11.2
44.0	7.1	7.9	8.6	9.4	9.7
46.0	6.0	6.8	7.4	8.1	
48.0	5.1	5.8	6.3	6.9	
50.0	4.2	4.8	5.3	5.8	
55.0		2.7	3.1	3.3	
危険角度 (°)	42	42	42	45	60
フック種類	24t	24t	24t	24t	24t
フック質量 (t)	0.88	0.88	0.88	0.88	0.88
掛数	2	2	2	2	2

HD性能 50mブーム+4.4m+22mヘビーリフトジブ

オフセット	10°	20°	30°	45°	60°
作業半径 (m)	荷重 (ton)	荷重 (ton)	荷重 (ton)	荷重 (ton)	荷重 (ton)
14.0	11.0				
16.0	11.0				
18.0	11.0	11.0			
20.0	11.0	11.0	11.0		
22.0	11.0	11.0	11.0		
24.0	11.0	11.0	11.0	9.5	
26.0	11.0	11.0	11.0	9.4	
28.0	11.0	11.0	11.0	9.3	7.6
30.0	11.0	11.0	11.0	9.2	7.6
32.0	11.0	11.0	10.9	9.2	7.6
34.0	11.0	11.0	10.8	9.1	7.6
36.0	11.0	11.0	10.7	9.1	7.6
38.0	10.6	11.0	10.6	9.1	7.6
40.0	9.2	10.3	10.6	9.1	7.6
42.0	8.0	8.9	9.7	9.1	7.6
44.0	6.8	7.7	8.5	9.1	7.6
46.0	5.8	6.6	7.3	8.0	7.6
48.0	4.8	5.6	6.2	6.9	
50.0	4.0	4.6	5.2	5.8	
55.0			3.0	3.3	
危険角度 (°)	47	48	48	49	60
フック種類	24t	24t	24t	24t	24t
フック質量 (t)	0.88	0.88	0.88	0.88	0.88
掛数	2	2	2	2	2

HD性能 53.9mブーム+4.4m+22mヘビーリフトジブ

オフセット	10°	20°	30°	45°	60°
作業半径 (m)	荷重 (ton)	荷重 (ton)	荷重 (ton)	荷重 (ton)	荷重 (ton)
14.0	9.0				
16.0	9.0				
18.0	9.0	9.0			
20.0	9.0	9.0			
22.0	9.0	9.0	8.8		
24.0	9.0	9.0	8.6		
26.0	9.0	9.0	8.5	6.9	
28.0	9.0	9.0	8.3	6.9	5.5
30.0	9.0	9.0	8.2	6.8	5.5
32.0	9.0	9.0	8.1	6.8	5.5
34.0	9.0	9.0	8.1	6.7	5.5
36.0	9.0	9.0	8.0	6.7	5.5
38.0	9.0	8.9	8.0	6.7	5.5
40.0	9.0	8.8	7.9	6.7	5.5
42.0	7.8	8.8	7.9	6.7	5.5
44.0	6.6	7.6	7.9	6.7	5.5
46.0	5.6	6.4	7.2	6.7	5.5
48.0	4.6	5.4	6.1	6.7	5.5
50.0	3.8	4.5	5.1	5.7	
55.0			2.9	3.3	
危険角度 (°)	49	51	51	51	60
フック種類	24t	24t	24t	24t	24t
フック質量 (t)	0.88	0.88	0.88	0.88	0.88
掛数	2	2	2	2	2

HE性能 14.4mブーム+4.4m+22mヘビーリフトジブ

オフセット	10°	20°	30°	45°	60°
作業半径 (m)	荷重 (ton)	荷重 (ton)	荷重 (ton)	荷重 (ton)	荷重 (ton)
8.0	54.0				
9.0	54.0				
10.0	54.0				
11.0	54.0				
12.0	54.0	52.8			
14.0	54.0	47.6			
16.0	48.3	43.4	38.0		
18.0	41.5	39.8	35.4		
20.0	36.1	36.8	33.1	28.2	
22.0	31.7	32.9	31.1	26.9	19.6
24.0	28.0	29.0	29.4	25.8	19.1
26.0	24.9	25.8	26.7	24.8	18.7
28.0	22.3	23.0	23.8	24.1	18.5
30.0	20.0	20.6	21.2	21.9	
32.0	18.0	18.5	19.0	19.5	
34.0	16.3	16.7	17.0		
36.0	14.7	15.0	15.2		
38.0	13.4				
危険角度 (°)	10	20	30	45	60
フック種類	83t	83t	83t	83t	83t
フック質量 (t)	1.00	1.00	1.00	1.00	1.00
掛数	6	6	6	6	6

HE性能 19.55mブーム+4.4m+22mヘビーリフトジブ

オフセット	10°	20°	30°	45°	60°
作業半径 (m)	荷重 (ton)	荷重 (ton)	荷重 (ton)	荷重 (ton)	荷重 (ton)
9.0	50.0				
10.0	50.0				
11.0	50.0				
12.0	50.0				
14.0	50.0	49.8			
16.0	46.2	45.7	39.1		
18.0	39.3	41.4	36.6		
20.0	33.8	35.7	34.4	29.4	
22.0	29.4	31.0	32.5	28.2	
24.0	25.7	27.1	28.5	27.1	20.9
26.0	22.6	23.9	25.0	26.2	20.5
28.0	20.0	21.1	22.1	23.4	20.2
30.0	17.7	18.6	19.5	20.6	20.0
32.0	15.7	16.5	17.3	18.2	18.6
34.0	13.9	14.6	15.3	15.9	
36.0	12.4	13.0	13.5	13.9	
38.0	11.0	11.5	11.8		
40.0	9.8	10.1	10.3		
42.0	8.6	8.8			
危険角度 (°)	10	20	30	45	60
フック種類	83t	83t	83t	83t	83t
フック質量 (t)	1.00	1.00	1.00	1.00	1.00
掛数	6	6	6	6	6

HE性能 23.6mブーム+4.4m+22mヘビーリフトジブ

オフセット	10°	20°	30°	45°	60°
作業半径 (m)	荷重 (ton)	荷重 (ton)	荷重 (ton)	荷重 (ton)	荷重 (ton)
10.0	45.0				
11.0	45.0				
12.0	45.0				
14.0	45.0	45.0			
16.0	45.0	45.0	42.2		
18.0	38.2	40.6	39.5		
20.0	32.7	34.8	36.8	31.2	
22.0	28.3	30.1	31.9	29.9	
24.0	24.6	26.2	27.8	28.8	22.2
26.0	21.4	22.9	24.3	26.1	21.7
28.0	18.8	20.1	21.3	22.8	21.4
30.0	16.5	17.6	18.7	20.0	20.9
32.0	14.4	15.5	16.4	17.5	18.1
34.0	12.7	13.6	14.4	15.3	15.6
36.0	11.1	11.9	12.5	13.3	
38.0	9.7	10.3	10.9	11.4	
40.0	8.4	9.0	9.4		
42.0	7.3	7.7	8.0		
44.0	6.2	6.5	6.7		
46.0	5.3	5.4			
危険角度 (°)	10	20	30	45	60
フック種類	83t	83t	83t	83t	83t
フック質量 (t)	1.00	1.00	1.00	1.00	1.00
掛数	4	4	4	4	4

HE性能 32mブーム+4.4m+22mヘビーリフトジブ

オフセット	10°	20°	30°	45°	60°
作業半径 (m)	荷重 (ton)	荷重 (ton)	荷重 (ton)	荷重 (ton)	荷重 (ton)
11.0	30.0				
12.0	30.0				
14.0	30.0	30.0			
16.0	30.0	29.4			
18.0	30.0	28.5	25.5		
20.0	30.0	27.6	24.8		
22.0	27.5	26.9	24.3	20.6	
24.0	23.8	25.6	23.8	20.2	16.9
26.0	20.7	22.3	23.3	19.9	16.7
28.0	18.0	19.5	20.9	19.7	16.6
30.0	15.7	17.0	18.3	19.5	16.6
32.0	13.7	14.9	16.0	17.4	16.6
34.0	11.9	13.0	14.0	15.2	15.9
36.0	10.4	11.3	12.2	13.2	13.7
38.0	9.0	9.8	10.6	11.5	11.8
40.0	7.7	8.5	9.1	9.9	
42.0	6.6	7.2	7.8	8.4	
44.0	5.5	6.1	6.6	7.0	
46.0	4.6	5.1	5.5		
48.0	3.7	4.2	4.5		
50.0		3.3	3.5		
危険角度 (°)	32	32	32	45	60
フック種類	83t	83t	83t	83t	83t
フック質量 (t)	1.00	1.00	1.00	1.00	1.00
掛数	4	4	4	4	4

HE性能 40mブーム+4.4m+22mヘビーリフトジブ

オフセット	10°	20°	30°	45°	60°
作業半径 (m)	荷重 (ton)	荷重 (ton)	荷重 (ton)	荷重 (ton)	荷重 (ton)
12.0	20.0				
14.0	20.0				
16.0	20.0	20.0			
18.0	20.0	20.0			
20.0	20.0	20.0	20.0		
22.0	20.0	20.0	20.0		
24.0	20.0	20.0	20.0	18.4	
26.0	20.0	20.0	20.0	18.2	15.2
28.0	17.9	19.4	20.0	18.0	15.1
30.0	15.5	17.0	18.3	17.8	15.0
32.0	13.5	14.8	16.0	17.5	15.0
34.0	11.7	12.9	14.0	15.3	15.0
36.0	10.2	11.2	12.3	13.4	14.1
38.0	8.7	9.7	10.6	11.6	12.2
40.0	7.5	8.4	9.2	10.1	10.5
42.0	6.3	7.1	7.8	8.6	8.9
44.0	5.3	6.0	6.6	7.3	
46.0	4.3	5.0	5.5	6.1	
48.0	3.4	4.0	4.5	4.9	
50.0		3.2	3.6	3.9	
危険角度 (°)	43	43	44	45	60
フック種類	24t	24t	24t	24t	24t
フック質量 (t)	0.88	0.88	0.88	0.88	0.88
掛数	2	2	2	2	2

HE性能 45mブーム+4.4m+22mヘビーリフトジブ

オフセット	10°	20°	30°	45°	60°
作業半径 (m)	荷重 (ton)	荷重 (ton)	荷重 (ton)	荷重 (ton)	荷重 (ton)
12.0	16.0				
14.0	16.0				
16.0	16.0	16.0			
18.0	16.0	16.0			
20.0	16.0	16.0	16.0		
22.0	16.0	16.0	16.0		
24.0	16.0	16.0	16.0	16.0	
26.0	16.0	16.0	16.0	15.8	13.2
28.0	16.0	16.0	16.0	15.7	13.1
30.0	15.3	16.0	16.0	15.5	13.0
32.0	13.2	14.6	15.8	15.4	13.0
34.0	11.5	12.7	13.8	15.3	13.0
36.0	9.9	11.0	12.1	13.3	13.0
38.0	8.5	9.5	10.5	11.6	12.2
40.0	7.2	8.2	9.0	10.0	10.5
42.0	6.0	6.9	7.7	8.6	9.0
44.0	5.0	5.8	6.5	7.3	7.6
46.0	4.0	4.8	5.4	6.1	
48.0	3.2	3.8	4.4	5.0	
50.0		3.0	3.5	3.9	
危険角度 (°)	48	48	48	50	60
フック種類	24t	24t	24t	24t	24t
フック質量 (t)	0.88	0.88	0.88	0.88	0.88
掛数	2	2	2	2	2

HE性能 50mブーム+4.4m+22mヘビーリフトジブ

オフセット	10°	20°	30°	45°	60°
作業半径 (m)	荷重 (ton)	荷重 (ton)	荷重 (ton)	荷重 (ton)	荷重 (ton)
14.0	11.0				
16.0	11.0				
18.0	11.0	11.0			
20.0	11.0	11.0	11.0		
22.0	11.0	11.0	11.0		
24.0	11.0	11.0	11.0	9.5	
26.0	11.0	11.0	11.0	9.4	
28.0	11.0	11.0	11.0	9.3	7.6
30.0	11.0	11.0	11.0	9.2	7.6
32.0	11.0	11.0	10.9	9.2	7.6
34.0	11.0	11.0	10.8	9.1	7.6
36.0	9.6	10.8	10.7	9.1	7.6
38.0	8.2	9.3	10.3	9.1	7.6
40.0	6.9	8.0	8.9	9.1	7.6
42.0	5.8	6.7	7.6	8.5	7.6
44.0	4.7	5.6	6.4	7.2	7.6
46.0	3.8	4.6	5.3	6.0	6.3
48.0	2.9	3.7	4.3	4.9	
50.0		2.8	3.4	3.9	
危険角度 (°)	52	52	52	54	60
フック種類	24t	24t	24t	24t	24t
フック質量 (t)	0.88	0.88	0.88	0.88	0.88
掛数	2	2	2	2	2

HE性能 53.9mブーム+4.4m+22mヘビーリフトジブ

オフセット	10°	20°	30°	45°	60°
作業半径 (m)	荷重 (ton)	荷重 (ton)	荷重 (ton)	荷重 (ton)	荷重 (ton)
14.0	9.0				
16.0	9.0				
18.0	9.0	9.0			
20.0	9.0	9.0			
22.0	9.0	9.0	8.8		
24.0	9.0	9.0	8.6		
26.0	9.0	9.0	8.5	6.9	
28.0	9.0	9.0	8.3	6.9	5.5
30.0	9.0	9.0	8.2	6.8	5.5
32.0	9.0	9.0	8.1	6.8	5.5
34.0	9.0	9.0	8.1	6.7	5.5
36.0	9.0	9.0	8.0	6.7	5.5
38.0	8.0	8.9	8.0	6.7	5.5
40.0	6.8	7.8	7.9	6.7	5.5
42.0	5.6	6.6	7.4	6.7	5.5
44.0	4.6	5.5	6.3	6.7	5.5
46.0	3.6	4.4	5.2	6.0	5.5
48.0	2.7	3.5	4.2	4.9	5.2
50.0		2.7	3.3	3.9	
危険角度 (°)	54	54	55	55	60
フック種類	24t	24t	24t	24t	24t
フック質量 (t)	0.88	0.88	0.88	0.88	0.88
掛数	2	2	2	2	2

HF性能 14.4mブーム+4.4m+22mヘビーリフトジブ

オフセット	10°	20°	30°	45°	60°
作業半径 (m)	荷重 (ton)	荷重 (ton)	荷重 (ton)	荷重 (ton)	荷重 (ton)
8.0	54.0				
9.0	54.0				
10.0	54.0				
11.0	54.0				
12.0	54.0	52.8			
14.0	53.1	47.6			
16.0	44.8	43.4	38.0		
18.0	38.4	39.8	35.4		
20.0	33.2	34.6	33.1	28.2	
22.0	29.1	30.3	31.1	26.9	19.6
24.0	25.7	26.6	27.4	25.8	19.1
26.0	22.7	23.4	24.1	24.8	18.7
28.0	20.1	20.7	21.3	22.0	18.5
30.0	17.9	18.4	18.9	19.5	
32.0	16.1	16.5	16.8	17.2	
34.0	14.5	14.8	15.0		
36.0	13.1	13.3	13.4		
38.0	11.8				
危険角度 (°)	10	20	30	45	60
フック種類	83t	83t	83t	83t	83t
フック質量 (t)	1.00	1.00	1.00	1.00	1.00
掛数	6	6	6	6	6

HF性能 19.55mブーム+4.4m+22mヘビーリフトジブ

オフセット	10°	20°	30°	45°	60°
作業半径 (m)	荷重 (ton)	荷重 (ton)	荷重 (ton)	荷重 (ton)	荷重 (ton)
9.0	50.0				
10.0	50.0				
11.0	50.0				
12.0	50.0				
14.0	50.0	49.8			
16.0	42.6	45.0	39.1		
18.0	36.2	38.2	36.6		
20.0	31.0	32.8	34.4	29.4	
22.0	26.9	28.4	30.0	28.2	
24.0	23.4	24.8	26.1	27.1	20.9
26.0	20.5	21.7	22.8	24.0	20.5
28.0	18.0	19.1	20.0	21.0	20.2
30.0	15.8	16.8	17.6	18.4	19.0
32.0	14.0	14.8	15.5	16.2	16.5
34.0	12.3	13.0	13.6	14.2	
36.0	10.8	11.4	11.9	12.4	
38.0	9.5	10.0	10.4		
40.0	8.4	8.7	8.9		
42.0	7.3	7.5			
危険角度 (°)	10	20	30	45	60
フック種類	83t	83t	83t	83t	83t
フック質量 (t)	1.00	1.00	1.00	1.00	1.00
掛数	6	6	6	6	6

HF性能 23.6mブーム+4.4m+22mヘビーリフトジブ

オフセット	10°	20°	30°	45°	60°
作業半径 (m)	荷重 (ton)	荷重 (ton)	荷重 (ton)	荷重 (ton)	荷重 (ton)
10.0	45.0				
11.0	45.0				
12.0	45.0				
14.0	45.0	45.0			
16.0	41.5	44.3	42.2		
18.0	35.1	37.5	39.5		
20.0	29.9	32.0	34.0	31.2	
22.0	25.7	27.6	29.3	29.9	
24.0	22.2	23.9	25.4	27.2	22.2
26.0	19.3	20.7	22.1	23.6	21.7
28.0	16.8	18.1	19.3	20.6	21.4
30.0	14.6	15.7	16.8	18.0	18.6
32.0	12.7	13.7	14.6	15.7	16.2
34.0	11.0	11.9	12.7	13.6	14.0
36.0	9.5	10.3	11.0	11.7	
38.0	8.2	8.9	9.4	9.9	
40.0	7.0	7.6	8.0		
42.0	5.9	6.4	6.7		
44.0	5.0	5.3	5.4		
46.0	4.1	4.2			
危険角度 (°)	10	20	30	45	60
フック種類	83t	83t	83t	83t	83t
フック質量 (t)	1.00	1.00	1.00	1.00	1.00
掛数	4	4	4	4	4

HF性能 32mブーム+4.4m+22mヘビーリフトジブ

オフセット	10°	20°	30°	45°	60°
作業半径 (m)	荷重 (ton)	荷重 (ton)	荷重 (ton)	荷重 (ton)	荷重 (ton)
11.0	30.0				
12.0	30.0				
14.0	30.0	30.0			
16.0	30.0	29.4			
18.0	30.0	28.5	25.5		
20.0	29.2	27.6	24.8		
22.0	25.0	26.9	24.3	20.6	
24.0	21.5	23.3	23.8	20.2	16.9
26.0	18.6	20.2	21.7	19.9	16.7
28.0	16.0	17.5	18.9	19.7	16.6
30.0	13.9	15.2	16.4	17.8	16.6
32.0	12.0	13.2	14.2	15.6	16.3
34.0	10.3	11.4	12.3	13.5	14.2
36.0	8.8	9.8	10.6	11.7	12.2
38.0	7.5	8.4	9.1	10.0	10.3
40.0	6.3	7.1	7.8	8.5	
42.0	5.2	5.9	6.5	7.1	
44.0	4.3	4.9	5.3	5.8	
46.0	3.4	3.9	4.3		
48.0		3.0	3.3		
危険角度 (°)	37	37	38	45	60
フック種類	83t	83t	83t	83t	83t
フック質量 (t)	1.00	1.00	1.00	1.00	1.00
掛数	4	4	4	4	4

HF性能 40mブーム+4.4m+22mヘビーリフトジブ

オフセット	10°	20°	30°	45°	60°
作業半径 (m)	荷重 (ton)	荷重 (ton)	荷重 (ton)	荷重 (ton)	荷重 (ton)
12.0	20.0				
14.0	20.0				
16.0	20.0	20.0			
18.0	20.0	20.0			
20.0	20.0	20.0	20.0		
22.0	20.0	20.0	20.0		
24.0	20.0	20.0	20.0	18.4	
26.0	18.4	20.0	20.0	18.2	15.2
28.0	15.9	17.4	18.9	18.0	15.1
30.0	13.7	15.1	16.4	17.8	15.0
32.0	11.8	13.1	14.3	15.7	15.0
34.0	10.1	11.3	12.4	13.7	14.4
36.0	8.6	9.7	10.7	11.8	12.5
38.0	7.3	8.3	9.1	10.2	10.7
40.0	6.1	7.0	7.8	8.7	9.1
42.0	5.0	5.8	6.5	7.3	7.6
44.0	4.0	4.7	5.4	6.0	
46.0	3.1	3.8	4.3	4.9	
48.0		2.9	3.4	3.8	
50.0				2.8	
危険角度 (°)	46	46	47	47	60
フック種類	24t	24t	24t	24t	24t
フック質量 (t)	0.88	0.88	0.88	0.88	0.88
掛数	2	2	2	2	2

HF性能 45mブーム+4.4m+22mヘビーリフトジブ

オフセット	10°	20°	30°	45°	60°
作業半径 (m)	荷重 (ton)	荷重 (ton)	荷重 (ton)	荷重 (ton)	荷重 (ton)
12.0	16.0				
14.0	16.0				
16.0	16.0	16.0			
18.0	16.0	16.0			
20.0	16.0	16.0	16.0		
22.0	16.0	16.0	16.0		
24.0	16.0	16.0	16.0	16.0	
26.0	16.0	16.0	16.0	15.8	13.2
28.0	15.6	16.0	16.0	15.7	13.1
30.0	13.4	14.9	16.0	15.5	13.0
32.0	11.5	12.9	14.1	15.4	13.0
34.0	9.8	11.1	12.2	13.6	13.0
36.0	8.3	9.5	10.5	11.8	12.6
38.0	7.0	8.0	9.0	10.1	10.8
40.0	5.8	6.8	7.6	8.6	9.1
42.0	4.7	5.6	6.4	7.3	7.7
44.0	3.7	4.5	5.2	6.0	6.3
46.0	2.8	3.6	4.2	4.9	
48.0		2.7	3.2	3.8	
50.0				2.8	
危険角度 (°)	50	50	52	52	60
フック種類	24t	24t	24t	24t	24t
フック質量 (t)	0.88	0.88	0.88	0.88	0.88
掛数	2	2	2	2	2

HF性能 50mブーム+4.4m+22mヘビーリフトジブ

オフセット	10°	20°	30°	45°	60°
作業半径 (m)	荷重 (ton)	荷重 (ton)	荷重 (ton)	荷重 (ton)	荷重 (ton)
14.0	11.0				
16.0	11.0				
18.0	11.0	11.0			
20.0	11.0	11.0	11.0		
22.0	11.0	11.0	11.0		
24.0	11.0	11.0	11.0	9.5	
26.0	11.0	11.0	11.0	9.4	
28.0	11.0	11.0	11.0	9.3	7.6
30.0	11.0	11.0	11.0	9.2	7.6
32.0	11.0	11.0	10.9	9.2	7.6
34.0	9.6	10.9	10.8	9.1	7.6
36.0	8.1	9.3	10.4	9.1	7.6
38.0	6.7	7.9	8.8	9.1	7.6
40.0	5.5	6.6	7.5	8.6	7.6
42.0	4.5	5.4	6.2	7.2	7.6
44.0	3.5	4.3	5.1	6.0	6.4
46.0		3.4	4.1	4.8	5.1
48.0			3.1	3.8	
50.0				2.8	
危険角度 (°)	56	56	56	56	60
フック種類	24t	24t	24t	24t	24t
フック質量 (t)	0.88	0.88	0.88	0.88	0.88
掛数	2	2	2	2	2

HF性能 53.9mブーム+4.4m+22mヘビーリフトジブ

オフセット	10°	20°	30°	45°	60°
作業半径 (m)	荷重 (ton)	荷重 (ton)	荷重 (ton)	荷重 (ton)	荷重 (ton)
14.0	9.0				
16.0	9.0				
18.0	9.0	9.0			
20.0	9.0	9.0			
22.0	9.0	9.0	8.8		
24.0	9.0	9.0	8.6		
26.0	9.0	9.0	8.5	6.9	
28.0	9.0	9.0	8.3	6.9	5.5
30.0	9.0	9.0	8.2	6.8	5.5
32.0	9.0	9.0	8.1	6.8	5.5
34.0	9.0	9.0	8.1	6.7	5.5
36.0	7.9	9.0	8.0	6.7	5.5
38.0	6.6	7.7	8.0	6.7	5.5
40.0	5.4	6.4	7.4	6.7	5.5
42.0	4.3	5.3	6.1	6.7	5.5
44.0	3.3	4.2	5.0	5.9	5.5
46.0		3.2	4.0	4.8	5.2
48.0			3.0	3.8	4.0
50.0				2.8	
危険角度 (°)	57	58	58	58	60
フック種類	24t	24t	24t	24t	24t
フック質量 (t)	0.88	0.88	0.88	0.88	0.88
掛数	2	2	2	2	2

HG性能 14.4mブーム+4.4m+22mヘビーリフトジブ

オフセット	10°	20°	30°	45°	60°
作業半径 (m)	荷重 (ton)	荷重 (ton)	荷重 (ton)	荷重 (ton)	荷重 (ton)
8.0	54.0				
9.0	54.0				
10.0	54.0				
11.0	54.0				
12.0	54.0	52.8			
14.0	49.0	47.6			
16.0	41.2	43.1	38.0		
18.0	35.2	36.8	35.4		
20.0	30.3	31.5	32.6	28.2	
22.0	26.0	27.0	28.0	26.9	19.6
24.0	22.5	23.4	24.2	25.3	19.1
26.0	19.7	20.4	21.1	22.0	18.7
28.0	17.3	18.0	18.5	19.3	18.5
30.0	15.4	15.9	16.4	16.9	
32.0	13.7	14.1	14.5	14.8	
34.0	12.3	12.6	12.8		
36.0	11.0	11.2	11.3		
38.0	9.9				
危険角度 (°)	10	20	30	45	60
フック種類	83t	83t	83t	83t	83t
フック質量 (t)	1.00	1.00	1.00	1.00	1.00
掛数	6	6	6	6	6

HG性能 19.55mブーム+4.4m+22mヘビーリフトジブ

オフセット	10°	20°	30°	45°	60°
作業半径 (m)	荷重 (ton)	荷重 (ton)	荷重 (ton)	荷重 (ton)	荷重 (ton)
9.0	50.0				
10.0	50.0				
11.0	50.0				
12.0	50.0				
14.0	46.9	49.7			
16.0	39.1	41.5	39.1		
18.0	33.0	35.1	36.6		
20.0	28.2	30.0	31.4	29.4	
22.0	24.1	25.5	26.7	28.2	
24.0	20.7	21.8	22.9	24.4	20.9
26.0	17.9	18.9	19.8	21.1	20.5
28.0	15.5	16.4	17.2	18.3	19.0
30.0	13.6	14.3	15.0	15.9	16.4
32.0	11.9	12.6	13.1	13.8	14.1
34.0	10.5	11.0	11.5	12.0	
36.0	9.2	9.7	10.0	10.4	
38.0	8.1	8.5	8.8		
40.0	7.0	7.3	7.5		
42.0	6.0	6.2			
危険角度 (°)	10	20	30	45	60
フック種類	83t	83t	83t	83t	83t
フック質量 (t)	1.00	1.00	1.00	1.00	1.00
掛数	6	6	6	6	6

HG性能 23.6mブーム+4.4m+22mヘビーリフトジブ

オフセット	10°	20°	30°	45°	60°
作業半径 (m)	荷重 (ton)	荷重 (ton)	荷重 (ton)	荷重 (ton)	荷重 (ton)
10.0	45.0				
11.0	45.0				
12.0	45.0				
14.0	45.0	45.0			
16.0	38.0	40.8	42.2		
18.0	31.9	34.3	36.6		
20.0	27.1	29.2	30.9	31.2	
22.0	23.1	24.7	26.2	28.2	
24.0	19.7	21.1	22.3	24.0	22.2
26.0	16.9	18.1	19.2	20.6	21.7
28.0	14.6	15.6	16.6	17.8	18.7
30.0	12.6	13.5	14.3	15.4	16.1
32.0	11.0	11.7	12.4	13.3	13.8
34.0	9.4	10.2	10.8	11.5	11.8
36.0	8.0	8.8	9.3	9.9	
38.0	6.7	7.4	8.0	8.4	
40.0	5.6	6.2	6.6		
42.0	4.6	5.0	5.3		
44.0	3.7	4.0	4.1		
46.0		3.0			
危険角度 (°)	22	22	30	45	60
フック種類	83t	83t	83t	83t	83t
フック質量 (t)	1.00	1.00	1.00	1.00	1.00
掛数	4	4	4	4	4

HG性能 32mブーム+4.4m+22mヘビーリフトジブ

オフセット	10°	20°	30°	45°	60°
作業半径 (m)	荷重 (ton)	荷重 (ton)	荷重 (ton)	荷重 (ton)	荷重 (ton)
11.0	30.0				
12.0	30.0				
14.0	30.0	30.0			
16.0	30.0	29.4			
18.0	30.0	28.5	25.5		
20.0	26.4	27.6	24.8		
22.0	22.4	24.3	24.3	20.6	
24.0	19.1	20.6	22.0	20.2	16.9
26.0	16.3	17.6	18.9	19.9	16.7
28.0	14.0	15.2	16.2	17.6	16.6
30.0	12.0	13.1	14.0	15.3	16.1
32.0	10.2	11.3	12.2	13.2	13.9
34.0	8.7	9.7	10.5	11.4	12.0
36.0	7.3	8.2	9.1	9.9	10.3
38.0	6.0	6.9	7.7	8.5	8.7
40.0	4.9	5.7	6.4	7.1	
42.0	3.9	4.6	5.2	5.7	
44.0	3.0	3.6	4.1	4.5	
46.0			3.1		
危険角度 (°)	41	43	43	45	60
フック種類	83t	83t	83t	83t	83t
フック質量 (t)	1.00	1.00	1.00	1.00	1.00
掛数	4	4	4	4	4

HG性能 40mブーム+4.4m+22mヘビーリフトジブ

オフセット	10°	20°	30°	45°	60°
作業半径 (m)	荷重 (ton)	荷重 (ton)	荷重 (ton)	荷重 (ton)	荷重 (ton)
12.0	20.0				
14.0	20.0				
16.0	20.0	20.0			
18.0	20.0	20.0			
20.0	20.0	20.0	20.0		
22.0	20.0	20.0	20.0		
24.0	19.0	20.0	20.0	18.4	
26.0	16.2	17.6	18.9	18.2	15.2
28.0	13.9	15.1	16.3	17.8	15.1
30.0	11.8	13.0	14.1	15.4	15.0
32.0	10.0	11.3	12.2	13.3	14.1
34.0	8.5	9.6	10.5	11.6	12.2
36.0	7.1	8.1	9.1	10.0	10.5
38.0	5.8	6.8	7.7	8.6	9.0
40.0	4.7	5.6	6.4	7.3	7.7
42.0	3.7	4.5	5.2	6.0	6.2
44.0	2.7	3.5	4.1	4.8	
46.0			3.1	3.7	
危険角度 (°)	49	51	51	53	60
フック種類	24t	24t	24t	24t	24t
フック質量 (t)	0.88	0.88	0.88	0.88	0.88
掛数	2	2	2	2	2

HG性能 45mブーム+4.4m+22mヘビーリフトジブ

オフセット	10°	20°	30°	45°	60°
作業半径 (m)	荷重 (ton)	荷重 (ton)	荷重 (ton)	荷重 (ton)	荷重 (ton)
12.0	16.0				
14.0	16.0				
16.0	16.0	16.0			
18.0	16.0	16.0			
20.0	16.0	16.0	16.0		
22.0	16.0	16.0	16.0		
24.0	16.0	16.0	16.0	16.0	
26.0	15.9	16.0	16.0	15.8	13.2
28.0	13.6	14.9	16.0	15.7	13.1
30.0	11.5	12.9	13.9	15.3	13.0
32.0	9.7	11.1	12.0	13.3	13.0
34.0	8.2	9.4	10.4	11.5	12.2
36.0	6.8	7.9	9.0	9.9	10.5
38.0	5.5	6.6	7.5	8.6	9.1
40.0	4.4	5.4	6.2	7.2	7.7
42.0	3.4	4.3	5.0	5.9	6.3
44.0		3.3	4.0	4.7	5.0
46.0			3.0	3.7	
危険角度 (°)	55	55	55	57	60
フック種類	24t	24t	24t	24t	24t
フック質量 (t)	0.88	0.88	0.88	0.88	0.88
掛数	2	2	2	2	2

HG性能 50mブーム+4.4m+22mヘビーリフトジブ

オフセット	10°	20°	30°	45°	60°
作業半径 (m)	荷重 (ton)	荷重 (ton)	荷重 (ton)	荷重 (ton)	荷重 (ton)
14.0	11.0				
16.0	11.0				
18.0	11.0	11.0			
20.0	11.0	11.0	11.0		
22.0	11.0	11.0	11.0		
24.0	11.0	11.0	11.0	9.5	
26.0	11.0	11.0	11.0	9.4	
28.0	11.0	11.0	11.0	9.3	7.6
30.0	11.0	11.0	11.0	9.2	7.6
32.0	9.5	10.9	10.9	9.2	7.6
34.0	7.9	9.2	10.3	9.1	7.6
36.0	6.5	7.7	8.8	9.1	7.6
38.0	5.3	6.4	7.4	8.5	7.6
40.0	4.1	5.2	6.1	7.2	7.6
42.0	3.1	4.1	4.9	5.9	6.4
44.0		3.1	3.8	4.7	5.1
46.0			2.9	3.6	3.9
危険角度 (°)	58	58	58	60	60
フック種類	24t	24t	24t	24t	24t
フック質量 (t)	0.88	0.88	0.88	0.88	0.88
掛数	2	2	2	2	2

HG性能 53.9mブーム+4.4m+22mヘビーリフトジブ

オフセット	10°	20°	30°	45°	60°
作業半径 (m)	荷重 (ton)	荷重 (ton)	荷重 (ton)	荷重 (ton)	荷重 (ton)
14.0	9.0				
16.0	9.0				
18.0	9.0	9.0			
20.0	9.0	9.0			
22.0	9.0	9.0	8.8		
24.0	9.0	9.0	8.6		
26.0	9.0	9.0	8.5	6.9	
28.0	9.0	9.0	8.3	6.9	5.5
30.0	9.0	9.0	8.2	6.8	5.5
32.0	9.0	9.0	8.1	6.8	5.5
34.0	7.7	9.0	8.1	6.7	5.5
36.0	6.3	7.6	8.0	6.7	5.5
38.0	5.1	6.2	7.3	6.7	5.5
40.0	4.0	5.0	6.0	6.7	5.5
42.0	2.9	3.9	4.8	5.8	5.5
44.0		2.9	3.7	4.7	5.1
46.0			2.8	3.6	4.0
48.0					2.9
危険角度 (°)	60	61	61	62	62
フック種類	24t	24t	24t	24t	24t
フック質量 (t)	0.88	0.88	0.88	0.88	0.88
掛数	2	2	2	2	2

HA性能 14.4mブーム+4.4m+31mヘビーリフトジブ

オフセット	10°	20°	30°	45°	60°
作業半径 (m)	荷重 (ton)	荷重 (ton)	荷重 (ton)	荷重 (ton)	荷重 (ton)
11.0	35.0				
12.0	35.0				
14.0	35.0				
16.0	34.5	34.1			
18.0	34.5	33.8			
20.0	34.5	31.6			
22.0	33.1	29.2	26.1		
24.0	30.4	27.1	24.5		
26.0	28.2	25.4	23.1	19.7	
28.0	26.2	23.8	21.8	18.8	
30.0	24.5	22.4	20.7	18.0	13.1
32.0	23.0	21.2	19.7	17.3	12.8
34.0	21.6	20.2	18.9	16.7	12.5
36.0	20.5	19.2	18.1	16.2	12.3
38.0	19.4	18.3	17.4	15.8	12.2
40.0	18.5	17.6	16.8	15.5	
42.0	17.6	16.9	16.4	15.4	
44.0	16.9	16.4	16.0		
46.0	16.2	16.0			
危険角度 (°)	10	20	30	45	60
フック種類	83t	83t	83t	83t	83t
フック質量 (t)	1.00	1.00	1.00	1.00	1.00
掛数	4	4	4	4	4

HA性能 19.55mブーム+4.4m+31mヘビーリフトジブ

オフセット	10°	20°	30°	45°	60°
作業半径 (m)	荷重 (ton)	荷重 (ton)	荷重 (ton)	荷重 (ton)	荷重 (ton)
12.0	34.0				
14.0	34.0				
16.0	34.0				
18.0	34.0	34.0			
20.0	34.0	33.0			
22.0	34.0	30.6	26.8		
24.0	32.9	28.6	25.2		
26.0	30.5	26.8	23.9		
28.0	28.5	25.2	22.7	19.8	
30.0	26.6	23.9	21.6	19.0	
32.0	25.0	22.6	20.6	18.4	14.0
34.0	23.5	21.5	19.8	17.8	13.7
36.0	21.6	20.5	19.0	17.3	13.5
38.0	19.8	19.6	18.3	16.8	13.3
40.0	18.1	18.8	17.7	16.4	13.3
42.0	16.7	17.4	17.1	16.1	
44.0	15.3	15.9	16.5	15.9	
46.0	14.1	14.6	15.0	15.4	
48.0	13.0	13.3	13.7		
50.0	11.9	12.2			
危険角度 (°)	10	20	30	45	60
フック種類	83t	83t	83t	83t	83t
フック質量 (t)	1.00	1.00	1.00	1.00	1.00
掛数	4	4	4	4	4

HA性能 23.6mブーム+4.4m+31mヘビーリフトジブ

オフセット	10°	20°	30°	45°	60°
作業半径 (m)	荷重 (ton)	荷重 (ton)	荷重 (ton)	荷重 (ton)	荷重 (ton)
12.0	30.0				
14.0	30.0				
16.0	30.0				
18.0	30.0	30.0			
20.0	30.0	30.0			
22.0	30.0	30.0	27.2		
24.0	30.0	29.6	25.8		
26.0	30.0	27.8	24.4		
28.0	29.6	26.3	23.3	20.0	
30.0	26.9	24.9	22.2	19.3	
32.0	24.4	23.6	21.3	18.6	14.8
34.0	22.3	22.5	20.4	18.1	14.5
36.0	20.3	21.5	19.6	17.6	14.2
38.0	18.4	19.5	18.9	17.1	14.0
40.0	16.8	17.8	18.3	16.7	13.9
42.0	15.3	16.2	17.0	16.4	13.9
44.0	13.9	14.7	15.5	16.1	
46.0	12.7	13.4	14.0	14.7	
48.0	11.6	12.2	12.7	13.2	
50.0	10.5	11.0	11.4		
55.0	8.3	8.4			
危険角度 (°)	10	20	30	45	60
フック種類	83t	83t	83t	83t	83t
フック質量 (t)	1.00	1.00	1.00	1.00	1.00
掛数	4	4	4	4	4

HA性能 32mブーム+4.4m+31mヘビーリフトジブ

オフセット	10°	20°	30°	45°	60°
作業半径 (m)	荷重 (ton)	荷重 (ton)	荷重 (ton)	荷重 (ton)	荷重 (ton)
14.0	20.0				
16.0	20.0				
18.0	20.0				
20.0	20.0	20.0			
22.0	20.0	20.0			
24.0	20.0	20.0	19.6		
26.0	20.0	20.0	19.1		
28.0	20.0	20.0	18.6		
30.0	20.0	20.0	18.2	15.3	
32.0	20.0	19.6	17.8	15.0	
34.0	20.0	19.2	17.4	14.8	12.2
36.0	19.8	18.7	17.1	14.6	12.1
38.0	17.9	18.4	16.8	14.4	12.0
40.0	16.2	17.4	16.6	14.3	12.0
42.0	14.7	15.8	16.4	14.2	12.0
44.0	13.4	14.4	15.3	14.1	12.0
46.0	12.1	13.0	13.8	14.1	12.0
48.0	11.0	11.8	12.5	13.4	
50.0	9.9	10.7	11.3	12.0	
55.0	7.6	8.1	8.6		
60.0	5.7	6.0	6.2		
危険角度 (°)	15	20	30	45	60
フック種類	24t	24t	24t	24t	24t
フック質量 (t)	0.88	0.88	0.88	0.88	0.88
掛数	2	2	2	2	2

HA性能 40mブーム+4.4m+31mヘビーリフトジブ

オフセット	10°	20°	30°	45°	60°
作業半径 (m)	荷重 (ton)	荷重 (ton)	荷重 (ton)	荷重 (ton)	荷重 (ton)
16.0	14.0				
18.0	14.0				
20.0	14.0	14.0			
22.0	14.0	14.0			
24.0	14.0	14.0	14.0		
26.0	14.0	14.0	14.0		
28.0	14.0	14.0	14.0		
30.0	14.0	14.0	14.0	13.4	
32.0	14.0	14.0	14.0	13.2	
34.0	14.0	14.0	14.0	13.0	10.5
36.0	14.0	14.0	14.0	12.8	10.5
38.0	14.0	14.0	14.0	12.7	10.4
40.0	14.0	14.0	14.0	12.5	10.4
42.0	14.0	14.0	14.0	12.4	10.3
44.0	12.7	13.8	14.0	12.4	10.3
46.0	11.5	12.5	13.5	12.3	10.3
48.0	10.3	11.3	12.2	12.3	10.3
50.0	9.3	10.2	11.0	11.9	10.3
55.0	7.0	7.7	8.3	8.9	
60.0	5.1	5.6	6.0	6.4	
65.0	3.5	3.8	4.1		
危険角度 (°)	25	27	30	45	60
フック種類	24t	24t	24t	24t	24t
フック質量 (t)	0.88	0.88	0.88	0.88	0.88
掛数	2	2	2	2	2

HA性能 45mブーム+4.4m+31mヘビーリフトジブ

オフセット	10°	20°	30°	45°	60°
作業半径 (m)	荷重 (ton)	荷重 (ton)	荷重 (ton)	荷重 (ton)	荷重 (ton)
16.0	12.0				
18.0	12.0				
20.0	12.0	12.0			
22.0	12.0	12.0			
24.0	12.0	12.0			
26.0	12.0	12.0	12.0		
28.0	12.0	12.0	12.0		
30.0	12.0	12.0	12.0	11.5	
32.0	12.0	12.0	12.0	11.3	
34.0	12.0	12.0	12.0	11.2	9.0
36.0	12.0	12.0	12.0	11.0	8.9
38.0	12.0	12.0	12.0	10.9	8.9
40.0	12.0	12.0	12.0	10.8	8.8
42.0	12.0	12.0	12.0	10.7	8.8
44.0	11.6	12.0	12.0	10.6	8.8
46.0	10.6	11.4	12.0	10.6	8.8
48.0	9.8	10.5	11.2	10.6	8.8
50.0	8.9	9.6	10.3	10.6	8.8
55.0	6.7	7.4	8.1	8.8	
60.0	4.7	5.4	5.9	6.4	
65.0	3.1	3.6	4.0		
危険角度 (°)	35	37	39	45	60
フック種類	24t	24t	24t	24t	24t
フック質量 (t)	0.88	0.88	0.88	0.88	0.88
掛数	2	2	2	2	2

HA性能 50mブーム+4.4m+31mヘビーリフトジブ

オフセット	10°	20°	30°	45°	60°
作業半径 (m)	荷重 (ton)	荷重 (ton)	荷重 (ton)	荷重 (ton)	荷重 (ton)
16.0	9.0				
18.0	9.0				
20.0	9.0				
22.0	9.0	9.0			
24.0	9.0	9.0			
26.0	9.0	9.0	8.4		
28.0	9.0	9.0	8.2		
30.0	9.0	9.0	8.0		
32.0	9.0	9.0	7.8	6.3	
34.0	9.0	8.8	7.7	6.2	
36.0	9.0	8.6	7.5	6.1	4.7
38.0	9.0	8.4	7.4	6.0	4.7
40.0	9.0	8.3	7.3	6.0	4.7
42.0	9.0	8.1	7.2	5.9	4.7
44.0	8.9	8.0	7.2	5.9	4.7
46.0	8.8	7.9	7.1	5.9	4.7
48.0	8.1	7.9	7.1	5.9	4.7
50.0	7.4	7.8	7.0	5.9	4.7
55.0	5.9	6.4	6.9	5.9	4.7
60.0	4.4	5.1	5.4	5.9	
65.0	2.8	3.4	3.8	4.2	
危険角度 (°)	38	40	42	45	60
フック種類	24t	24t	24t	24t	24t
フック質量 (t)	0.88	0.88	0.88	0.88	0.88
掛数	2	2	2	2	2

HA性能 53.9mブーム+4.4m+31mヘビーリフトジブ

オフセット	10°	20°	30°	45°	60°
作業半径 (m)	荷重 (ton)	荷重 (ton)	荷重 (ton)	荷重 (ton)	荷重 (ton)
18.0	8.0				
20.0	8.0				
22.0	8.0	7.5			
24.0	8.0	7.2			
26.0	8.0	7.0	6.0		
28.0	8.0	6.8	5.8		
30.0	7.8	6.7	5.7		
32.0	7.6	6.5	5.6	4.3	
34.0	7.4	6.4	5.5	4.2	
36.0	7.2	6.2	5.4	4.2	3.1
38.0	7.0	6.1	5.3	4.1	3.1
40.0	6.9	6.0	5.2	4.1	3.1
42.0	6.7	5.9	5.1	4.1	3.1
44.0	6.6	5.8	5.1	4.1	3.1
46.0	6.5	5.8	5.1	4.1	3.1
48.0	6.4	5.7	5.0	4.1	3.1
50.0	6.1	5.7	5.0	4.1	3.1
55.0	4.7	5.2	5.0	4.1	3.1
60.0	3.4	3.9	4.3	4.1	
65.0		2.8	3.1	3.5	
危険角度 (°)	46	46	47	48	60
フック種類	24t	24t	24t	24t	24t
フック質量 (t)	0.88	0.88	0.88	0.88	0.88
掛数	2	2	2	2	2

HB性能 14.4mブーム+4.4m+31mヘビーリフトジブ

オフセット	10°	20°	30°	45°	60°
作業半径 (m)	荷重 (ton)	荷重 (ton)	荷重 (ton)	荷重 (ton)	荷重 (ton)
11.0	35.0				
12.0	35.0				
14.0	35.0				
16.0	34.5	34.1			
18.0	34.5	33.8			
20.0	34.5	31.6			
22.0	33.1	29.2	26.1		
24.0	30.4	27.1	24.5		
26.0	28.2	25.4	23.1	19.7	
28.0	26.2	23.8	21.8	18.8	
30.0	24.5	22.4	20.7	18.0	13.1
32.0	23.0	21.2	19.7	17.3	12.8
34.0	21.6	20.2	18.9	16.7	12.5
36.0	20.5	19.2	18.1	16.2	12.3
38.0	19.4	18.3	17.4	15.8	12.2
40.0	18.5	17.6	16.8	15.5	
42.0	17.3	16.9	16.4	15.4	
44.0	16.0	16.3	16.0		
46.0	14.8	15.0			
危険角度 (°)	10	20	30	45	60
フック種類	83t	83t	83t	83t	83t
フック質量 (t)	1.00	1.00	1.00	1.00	1.00
掛数	4	4	4	4	4

HB性能 19.55mブーム+4.4m+31mヘビーリフトジブ

オフセット	10°	20°	30°	45°	60°
作業半径 (m)	荷重 (ton)	荷重 (ton)	荷重 (ton)	荷重 (ton)	荷重 (ton)
12.0	34.0				
14.0	34.0				
16.0	34.0				
18.0	34.0	34.0			
20.0	34.0	33.0			
22.0	34.0	30.6	26.8		
24.0	32.9	28.6	25.2		
26.0	30.5	26.8	23.9		
28.0	28.5	25.2	22.7	19.8	
30.0	26.6	23.9	21.6	19.0	
32.0	24.1	22.6	20.6	18.4	14.0
34.0	21.9	21.5	19.8	17.8	13.7
36.0	19.9	20.5	19.0	17.3	13.5
38.0	18.2	19.1	18.3	16.8	13.3
40.0	16.6	17.4	17.7	16.4	13.3
42.0	15.2	15.9	16.6	16.1	
44.0	13.9	14.5	15.1	15.7	
46.0	12.8	13.3	13.7	14.0	
48.0	11.7	12.1	12.4		
50.0	10.7	11.0			
危険角度 (°)	10	20	30	45	60
フック種類	83t	83t	83t	83t	83t
フック質量 (t)	1.00	1.00	1.00	1.00	1.00
掛数	4	4	4	4	4

HB性能 23.6mブーム+4.4m+31mヘビーリフトジブ

オフセット	10°	20°	30°	45°	60°
作業半径 (m)	荷重 (ton)	荷重 (ton)	荷重 (ton)	荷重 (ton)	荷重 (ton)
12.0	30.0				
14.0	30.0				
16.0	30.0				
18.0	30.0	30.0			
20.0	30.0	30.0			
22.0	30.0	30.0	27.2		
24.0	30.0	29.6	25.8		
26.0	30.0	27.8	24.4		
28.0	28.1	26.3	23.3	20.0	
30.0	25.2	24.9	22.2	19.3	
32.0	22.7	23.6	21.3	18.6	14.8
34.0	20.5	21.9	20.4	18.1	14.5
36.0	18.6	19.8	19.6	17.6	14.2
38.0	16.8	17.9	18.9	17.1	14.0
40.0	15.3	16.3	17.2	16.7	13.9
42.0	13.8	14.7	15.6	16.4	13.9
44.0	12.6	13.4	14.1	14.9	
46.0	11.4	12.1	12.7	13.4	
48.0	10.3	10.9	11.4	11.9	
50.0	9.3	9.8	10.2		
55.0	7.2	7.3			
危険角度 (°)	10	20	30	45	60
フック種類	83t	83t	83t	83t	83t
フック質量 (t)	1.00	1.00	1.00	1.00	1.00
掛数	4	4	4	4	4

HB性能 32mブーム+4.4m+31mヘビーリフトジブ

オフセット	10°	20°	30°	45°	60°
作業半径 (m)	荷重 (ton)	荷重 (ton)	荷重 (ton)	荷重 (ton)	荷重 (ton)
14.0	20.0				
16.0	20.0				
18.0	20.0				
20.0	20.0	20.0			
22.0	20.0	20.0			
24.0	20.0	20.0	19.6		
26.0	20.0	20.0	19.1		
28.0	20.0	20.0	18.6		
30.0	20.0	20.0	18.2	15.3	
32.0	20.0	19.6	17.8	15.0	
34.0	20.0	19.2	17.4	14.8	12.2
36.0	18.1	18.7	17.1	14.6	12.1
38.0	16.3	17.6	16.8	14.4	12.0
40.0	14.7	15.9	16.6	14.3	12.0
42.0	13.3	14.4	15.4	14.2	12.0
44.0	12.0	13.0	13.9	14.1	12.0
46.0	10.8	11.7	12.5	13.5	12.0
48.0	9.7	10.5	11.2	12.1	
50.0	8.7	9.4	10.1	10.8	
55.0	6.5	7.0	7.5		
60.0	4.7	5.0	5.1		
危険角度 (°)	15	20	30	45	60
フック種類	24t	24t	24t	24t	24t
フック質量 (t)	0.88	0.88	0.88	0.88	0.88
掛数	2	2	2	2	2

HB性能 40mブーム+4.4m+31mヘビーリフトジブ

オフセット	10°	20°	30°	45°	60°
作業半径 (m)	荷重 (ton)	荷重 (ton)	荷重 (ton)	荷重 (ton)	荷重 (ton)
16.0	14.0				
18.0	14.0				
20.0	14.0	14.0			
22.0	14.0	14.0			
24.0	14.0	14.0	14.0		
26.0	14.0	14.0	14.0		
28.0	14.0	14.0	14.0		
30.0	14.0	14.0	14.0	13.4	
32.0	14.0	14.0	14.0	13.2	
34.0	14.0	14.0	14.0	13.0	10.5
36.0	14.0	14.0	14.0	12.8	10.5
38.0	14.0	14.0	14.0	12.7	10.4
40.0	14.0	14.0	14.0	12.5	10.4
42.0	12.7	13.9	14.0	12.4	10.3
44.0	11.4	12.5	13.5	12.4	10.3
46.0	10.2	11.2	12.2	12.3	10.3
48.0	9.1	10.0	10.9	12.0	10.3
50.0	8.1	9.0	9.8	10.7	10.3
55.0	5.9	6.6	7.2	7.8	
60.0	4.1	4.6	5.0	5.3	
65.0		2.9	3.1		
危険角度 (°)	33	33	35	45	60
フック種類	24t	24t	24t	24t	24t
フック質量 (t)	0.88	0.88	0.88	0.88	0.88
掛数	2	2	2	2	2

HB性能 45mブーム+4.4m+31mヘビーリフトジブ

オフセット	10°	20°	30°	45°	60°
作業半径 (m)	荷重 (ton)	荷重 (ton)	荷重 (ton)	荷重 (ton)	荷重 (ton)
16.0	12.0				
18.0	12.0				
20.0	12.0	12.0			
22.0	12.0	12.0			
24.0	12.0	12.0			
26.0	12.0	12.0	12.0		
28.0	12.0	12.0	12.0		
30.0	12.0	12.0	12.0	11.5	
32.0	12.0	12.0	12.0	11.3	
34.0	12.0	12.0	12.0	11.2	9.0
36.0	12.0	12.0	12.0	11.0	8.9
38.0	12.0	12.0	12.0	10.9	8.9
40.0	12.0	12.0	12.0	10.8	8.8
42.0	12.0	12.0	12.0	10.7	8.8
44.0	11.0	12.0	12.0	10.6	8.8
46.0	9.8	10.9	11.9	10.6	8.8
48.0	8.7	9.8	10.7	10.6	8.8
50.0	7.7	8.7	9.6	10.6	8.8
55.0	5.5	6.3	7.0	7.8	
60.0	3.7	4.4	4.9	5.4	
65.0		2.7	3.0		
危険角度 (°)	39	40	42	45	60
フック種類	24t	24t	24t	24t	24t
フック質量 (t)	0.88	0.88	0.88	0.88	0.88
掛数	2	2	2	2	2

HB性能 50mブーム+4.4m+31mヘビーリフトジブ

オフセット	10°	20°	30°	45°	60°
作業半径 (m)	荷重 (ton)	荷重 (ton)	荷重 (ton)	荷重 (ton)	荷重 (ton)
16.0	9.0				
18.0	9.0				
20.0	9.0				
22.0	9.0	9.0			
24.0	9.0	9.0			
26.0	9.0	9.0	8.4		
28.0	9.0	9.0	8.2		
30.0	9.0	9.0	8.0		
32.0	9.0	9.0	7.8	6.3	
34.0	9.0	8.8	7.7	6.2	
36.0	9.0	8.6	7.5	6.1	4.7
38.0	9.0	8.4	7.4	6.0	4.7
40.0	9.0	8.3	7.3	6.0	4.7
42.0	9.0	8.1	7.2	5.9	4.7
44.0	8.9	8.0	7.2	5.9	4.7
46.0	8.8	7.9	7.1	5.9	4.7
48.0	8.1	7.9	7.1	5.9	4.7
50.0	7.4	7.8	7.0	5.9	4.7
55.0	5.2	6.1	6.8	5.9	4.7
60.0	3.4	4.1	4.7	5.3	
65.0			2.9	3.3	
危険角度 (°)	44	46	46	47	60
フック種類	24t	24t	24t	24t	24t
フック質量 (t)	0.88	0.88	0.88	0.88	0.88
掛数	2	2	2	2	2

HB性能 53.9mブーム+4.4m+31mヘビーリフトジブ

オフセット	10°	20°	30°	45°	60°
作業半径 (m)	荷重 (ton)	荷重 (ton)	荷重 (ton)	荷重 (ton)	荷重 (ton)
18.0	8.0				
20.0	8.0				
22.0	8.0	7.5			
24.0	8.0	7.2			
26.0	8.0	7.0	6.0		
28.0	8.0	6.8	5.8		
30.0	7.8	6.7	5.7		
32.0	7.6	6.5	5.6	4.3	
34.0	7.4	6.4	5.5	4.2	
36.0	7.2	6.2	5.4	4.2	3.1
38.0	7.0	6.1	5.3	4.1	3.1
40.0	6.9	6.0	5.2	4.1	3.1
42.0	6.7	5.9	5.1	4.1	3.1
44.0	6.6	5.8	5.1	4.1	3.1
46.0	6.5	5.8	5.1	4.1	3.1
48.0	6.4	5.7	5.0	4.1	3.1
50.0	6.1	5.7	5.0	4.1	3.1
55.0	4.7	5.2	5.0	4.1	3.1
60.0	3.2	3.9	4.3	4.1	
65.0			2.8	3.3	
危険角度 (°)	48	49	49	50	60
フック種類	24t	24t	24t	24t	24t
フック質量 (t)	0.88	0.88	0.88	0.88	0.88
掛数	2	2	2	2	2

HC性能 14.4mブーム+4.4m+31mヘビーリフトジブ

オフセット	10°	20°	30°	45°	60°
作業半径 (m)	荷重 (ton)	荷重 (ton)	荷重 (ton)	荷重 (ton)	荷重 (ton)
11.0	35.0				
12.0	35.0				
14.0	35.0				
16.0	34.5	34.1			
18.0	34.5	33.8			
20.0	34.5	31.6			
22.0	33.1	29.2	26.1		
24.0	30.4	27.1	24.5		
26.0	28.2	25.4	23.1	19.7	
28.0	26.2	23.8	21.8	18.8	
30.0	24.5	22.4	20.7	18.0	13.1
32.0	23.0	21.2	19.7	17.3	12.8
34.0	21.6	20.2	18.9	16.7	12.5
36.0	20.2	19.2	18.1	16.2	12.3
38.0	18.6	18.3	17.4	15.8	12.2
40.0	17.1	17.6	16.8	15.5	
42.0	15.8	16.2	16.4	15.4	
44.0	14.6	14.9	15.2		
46.0	13.5	13.7			
危険角度 (°)	10	20	30	45	60
フック種類	83t	83t	83t	83t	83t
フック質量 (t)	1.00	1.00	1.00	1.00	1.00
掛数	4	4	4	4	4

HC性能 19.55mブーム+4.4m+31mヘビーリフトジブ

オフセット	10°	20°	30°	45°	60°
作業半径 (m)	荷重 (ton)	荷重 (ton)	荷重 (ton)	荷重 (ton)	荷重 (ton)
12.0	34.0				
14.0	34.0				
16.0	34.0				
18.0	34.0	34.0			
20.0	34.0	33.0			
22.0	34.0	30.6	26.8		
24.0	32.9	28.6	25.2		
26.0	30.3	26.8	23.9		
28.0	27.2	25.2	22.7	19.8	
30.0	24.5	23.9	21.6	19.0	
32.0	22.2	22.6	20.6	18.4	14.0
34.0	20.1	21.2	19.8	17.8	13.7
36.0	18.2	19.2	19.0	17.3	13.5
38.0	16.6	17.5	18.3	16.8	13.3
40.0	15.1	15.9	16.7	16.4	13.3
42.0	13.8	14.5	15.1	15.9	
44.0	12.5	13.1	13.7	14.3	
46.0	11.4	11.9	12.4	12.7	
48.0	10.4	10.8	11.1		
50.0	9.5	9.7			
危険角度 (°)	10	20	30	45	60
フック種類	83t	83t	83t	83t	83t
フック質量 (t)	1.00	1.00	1.00	1.00	1.00
掛数	4	4	4	4	4

HC性能 23.6mブーム+4.4m+31mヘビーリフトジブ

オフセット	10°	20°	30°	45°	60°
作業半径 (m)	荷重 (ton)	荷重 (ton)	荷重 (ton)	荷重 (ton)	荷重 (ton)
12.0	30.0				
14.0	30.0				
16.0	30.0				
18.0	30.0	30.0			
20.0	30.0	30.0			
22.0	30.0	30.0	27.2		
24.0	30.0	29.6	25.8		
26.0	29.1	27.8	24.4		
28.0	25.9	26.3	23.3	20.0	
30.0	23.2	24.8	22.2	19.3	
32.0	20.8	22.3	21.3	18.6	14.8
34.0	18.7	20.1	20.4	18.1	14.5
36.0	16.9	18.1	19.3	17.6	14.2
38.0	15.2	16.3	17.4	17.1	14.0
40.0	13.7	14.7	15.7	16.7	13.9
42.0	12.4	13.3	14.1	15.2	13.9
44.0	11.2	12.0	12.7	13.6	
46.0	10.1	10.8	11.4	12.1	
48.0	9.0	9.6	10.2	10.6	
50.0	8.1	8.6	9.0		
55.0	6.1	6.2			
危険角度 (°)	10	20	30	45	60
フック種類	83t	83t	83t	83t	83t
フック質量 (t)	1.00	1.00	1.00	1.00	1.00
掛数	4	4	4	4	4

HC性能 32mブーム+4.4m+31mヘビーリフトジブ

オフセット	10°	20°	30°	45°	60°
作業半径 (m)	荷重 (ton)	荷重 (ton)	荷重 (ton)	荷重 (ton)	荷重 (ton)
14.0	20.0				
16.0	20.0				
18.0	20.0				
20.0	20.0	20.0			
22.0	20.0	20.0			
24.0	20.0	20.0	19.6		
26.0	20.0	20.0	19.1		
28.0	20.0	20.0	18.6		
30.0	20.0	20.0	18.2	15.3	
32.0	20.0	19.6	17.8	15.0	
34.0	18.2	19.2	17.4	14.8	12.2
36.0	16.4	17.8	17.1	14.6	12.1
38.0	14.7	16.0	16.8	14.4	12.0
40.0	13.2	14.4	15.5	14.3	12.0
42.0	11.8	12.9	13.9	14.2	12.0
44.0	10.6	11.6	12.5	13.6	12.0
46.0	9.5	10.4	11.2	12.2	12.0
48.0	8.4	9.3	10.0	10.8	
50.0	7.5	8.2	8.9	9.5	
55.0	5.4	5.9	6.4		
60.0	3.7	4.0	4.1		
危険角度 (°)	15	20	30	45	60
フック種類	24t	24t	24t	24t	24t
フック質量 (t)	0.88	0.88	0.88	0.88	0.88
掛数	2	2	2	2	2

HC性能 40mブーム+4.4m+31mヘビーリフトジブ

オフセット	10°	20°	30°	45°	60°
作業半径 (m)	荷重 (ton)	荷重 (ton)	荷重 (ton)	荷重 (ton)	荷重 (ton)
16.0	14.0				
18.0	14.0				
20.0	14.0	14.0			
22.0	14.0	14.0			
24.0	14.0	14.0	14.0		
26.0	14.0	14.0	14.0		
28.0	14.0	14.0	14.0		
30.0	14.0	14.0	14.0	13.4	
32.0	14.0	14.0	14.0	13.2	
34.0	14.0	14.0	14.0	13.0	10.5
36.0	14.0	14.0	14.0	12.8	10.5
38.0	14.0	14.0	14.0	12.7	10.4
40.0	12.6	13.9	14.0	12.5	10.4
42.0	11.2	12.4	13.5	12.4	10.3
44.0	10.0	11.1	12.1	12.4	10.3
46.0	8.8	9.9	10.8	12.0	10.3
48.0	7.8	8.8	9.6	10.7	10.3
50.0	6.9	7.7	8.5	9.5	9.9
55.0	4.8	5.5	6.1	6.7	
60.0	3.1	3.6	4.0	4.3	
危険角度 (°)	36	39	41	45	60
フック種類	24t	24t	24t	24t	24t
フック質量 (t)	0.88	0.88	0.88	0.88	0.88
掛数	2	2	2	2	2

HC性能 45mブーム+4.4m+31mヘビーリフトジブ

オフセット	10°	20°	30°	45°	60°
作業半径 (m)	荷重 (ton)	荷重 (ton)	荷重 (ton)	荷重 (ton)	荷重 (ton)
16.0	12.0				
18.0	12.0				
20.0	12.0	12.0			
22.0	12.0	12.0			
24.0	12.0	12.0			
26.0	12.0	12.0	12.0		
28.0	12.0	12.0	12.0		
30.0	12.0	12.0	12.0	11.5	
32.0	12.0	12.0	12.0	11.3	
34.0	12.0	12.0	12.0	11.2	9.0
36.0	12.0	12.0	12.0	11.0	8.9
38.0	12.0	12.0	12.0	10.9	8.9
40.0	12.0	12.0	12.0	10.8	8.8
42.0	10.9	12.0	12.0	10.7	8.8
44.0	9.6	10.8	11.9	10.6	8.8
46.0	8.5	9.6	10.6	10.6	8.8
48.0	7.5	8.5	9.4	10.6	8.8
50.0	6.5	7.5	8.3	9.4	8.8
55.0	4.4	5.2	5.9	6.7	
60.0	2.7	3.3	3.9	4.4	
危険角度 (°)	41	43	45	45	60
フック種類	24t	24t	24t	24t	24t
フック質量 (t)	0.88	0.88	0.88	0.88	0.88
掛数	2	2	2	2	2

HC性能 50mブーム+4.4m+31mヘビーリフトジブ

オフセット	10°	20°	30°	45°	60°
作業半径 (m)	荷重 (ton)	荷重 (ton)	荷重 (ton)	荷重 (ton)	荷重 (ton)
16.0	9.0				
18.0	9.0				
20.0	9.0				
22.0	9.0	9.0			
24.0	9.0	9.0			
26.0	9.0	9.0	8.4		
28.0	9.0	9.0	8.2		
30.0	9.0	9.0	8.0		
32.0	9.0	9.0	7.8	6.3	
34.0	9.0	8.8	7.7	6.2	
36.0	9.0	8.6	7.5	6.1	4.7
38.0	9.0	8.4	7.4	6.0	4.7
40.0	9.0	8.3	7.3	6.0	4.7
42.0	9.0	8.1	7.2	5.9	4.7
44.0	8.9	8.0	7.2	5.9	4.7
46.0	8.2	7.9	7.1	5.9	4.7
48.0	7.1	7.9	7.1	5.9	4.7
50.0	6.2	7.2	7.0	5.9	4.7
55.0	4.1	5.0	5.7	5.9	4.7
60.0		3.1	3.7	4.3	
危険角度 (°)	49	49	50	51	60
フック種類	24t	24t	24t	24t	24t
フック質量 (t)	0.88	0.88	0.88	0.88	0.88
掛数	2	2	2	2	2

HC性能 53.9mブーム+4.4m+31mヘビーリフトジブ

オフセット	10°	20°	30°	45°	60°
作業半径 (m)	荷重 (ton)	荷重 (ton)	荷重 (ton)	荷重 (ton)	荷重 (ton)
18.0	8.0				
20.0	8.0				
22.0	8.0	7.5			
24.0	8.0	7.2			
26.0	8.0	7.0	6.0		
28.0	8.0	6.8	5.8		
30.0	7.8	6.7	5.7		
32.0	7.6	6.5	5.6	4.3	
34.0	7.4	6.4	5.5	4.2	
36.0	7.2	6.2	5.4	4.2	3.1
38.0	7.0	6.1	5.3	4.1	3.1
40.0	6.9	6.0	5.2	4.1	3.1
42.0	6.7	5.9	5.1	4.1	3.1
44.0	6.6	5.8	5.1	4.1	3.1
46.0	6.5	5.8	5.1	4.1	3.1
48.0	6.4	5.7	5.0	4.1	3.1
50.0	6.0	5.7	5.0	4.1	3.1
55.0	3.9	4.8	5.0	4.1	3.1
60.0		2.9	3.6	4.1	
危険角度 (°)	51	51	52	53	60
フック種類	24t	24t	24t	24t	24t
フック質量 (t)	0.88	0.88	0.88	0.88	0.88
掛数	2	2	2	2	2

HD性能 14.4mブーム+4.4m+31mヘビーリフトジブ

オフセット	10°	20°	30°	45°	60°
作業半径 (m)	荷重 (ton)	荷重 (ton)	荷重 (ton)	荷重 (ton)	荷重 (ton)
11.0	35.0				
12.0	35.0				
14.0	35.0				
16.0	34.5	34.1			
18.0	34.5	33.8			
20.0	34.5	31.6			
22.0	33.1	29.2	26.1		
24.0	30.4	27.1	24.5		
26.0	28.2	25.4	23.1	19.7	
28.0	26.2	23.8	21.8	18.8	
30.0	24.4	22.4	20.7	18.0	13.1
32.0	22.2	21.2	19.7	17.3	12.8
34.0	20.3	20.2	18.9	16.7	12.5
36.0	18.5	19.2	18.1	16.2	12.3
38.0	17.0	17.6	17.4	15.8	12.2
40.0	15.6	16.1	16.6	15.5	
42.0	14.4	14.8	15.2	15.4	
44.0	13.2	13.5	13.8		
46.0	12.2	12.4			
危険角度 (°)	10	20	30	45	60
フック種類	83t	83t	83t	83t	83t
フック質量 (t)	1.00	1.00	1.00	1.00	1.00
掛数	4	4	4	4	4

HD性能 19.55mブーム+4.4m+31mヘビーリフトジブ

オフセット	10°	20°	30°	45°	60°
作業半径 (m)	荷重 (ton)	荷重 (ton)	荷重 (ton)	荷重 (ton)	荷重 (ton)
12.0	34.0				
14.0	34.0				
16.0	34.0				
18.0	34.0	34.0			
20.0	34.0	33.0			
22.0	34.0	30.6	26.8		
24.0	31.4	28.6	25.2		
26.0	28.0	26.8	23.9		
28.0	25.0	25.2	22.7	19.8	
30.0	22.5	23.8	21.6	19.0	
32.0	20.2	21.5	20.6	18.4	14.0
34.0	18.3	19.4	19.8	17.8	13.7
36.0	16.5	17.5	18.5	17.3	13.5
38.0	15.0	15.9	16.7	16.8	13.3
40.0	13.6	14.4	15.1	16.1	13.3
42.0	12.3	13.0	13.7	14.4	
44.0	11.2	11.8	12.3	12.9	
46.0	10.1	10.6	11.0	11.4	
48.0	9.1	9.5	9.8		
50.0	8.3	8.5			
危険角度 (°)	10	20	30	45	60
フック種類	83t	83t	83t	83t	83t
フック質量 (t)	1.00	1.00	1.00	1.00	1.00
掛数	4	4	4	4	4

HD性能 23.6mブーム+4.4m+31mヘビーリフトジブ

オフセット	10°	20°	30°	45°	60°
作業半径 (m)	荷重 (ton)	荷重 (ton)	荷重 (ton)	荷重 (ton)	荷重 (ton)
12.0	30.0				
14.0	30.0				
16.0	30.0				
18.0	30.0	30.0			
20.0	30.0	30.0			
22.0	30.0	30.0	27.2		
24.0	30.0	29.6	25.8		
26.0	26.7	27.8	24.4		
28.0	23.7	25.5	23.3	20.0	
30.0	21.2	22.8	22.2	19.3	
32.0	18.9	20.4	21.3	18.6	14.8
34.0	16.9	18.3	19.6	18.1	14.5
36.0	15.2	16.4	17.6	17.6	14.2
38.0	13.6	14.7	15.8	17.1	14.0
40.0	12.2	13.2	14.1	15.4	13.9
42.0	10.9	11.8	12.7	13.7	13.9
44.0	9.8	10.6	11.3	12.2	
46.0	7.8	9.4	10.1	10.7	
48.0	7.8	8.4	8.9	9.4	
50.0	6.9	7.4	7.8		
55.0	4.9	5.1			
危険角度 (°)	10	20	30	45	60
フック種類	83t	83t	83t	83t	83t
フック質量 (t)	1.00	1.00	1.00	1.00	1.00
掛数	4	4	4	4	4

HD性能 32mブーム+4.4m+31mヘビーリフトジブ

オフセット	10°	20°	30°	45°	60°
作業半径 (m)	荷重 (ton)	荷重 (ton)	荷重 (ton)	荷重 (ton)	荷重 (ton)
14.0	20.0				
16.0	20.0				
18.0	20.0				
20.0	20.0	20.0			
22.0	20.0	20.0			
24.0	20.0	20.0	19.6		
26.0	20.0	20.0	19.1		
28.0	20.0	20.0	18.6		
30.0	20.0	20.0	18.2	15.3	
32.0	18.4	19.6	17.8	15.0	
34.0	16.4	18.0	17.4	14.8	12.2
36.0	14.7	16.1	17.1	14.6	12.1
38.0	13.1	14.4	15.6	14.4	12.0
40.0	11.7	12.8	13.9	14.3	12.0
42.0	10.4	11.5	12.5	13.7	12.0
44.0	9.2	10.2	11.1	12.2	12.0
46.0	8.2	9.0	9.9	10.8	11.3
48.0	7.2	8.0	8.7	9.5	
50.0	6.3	7.0	7.6	8.3	
55.0	4.3	4.8	5.3		
60.0		3.0	3.1		
危険角度 (°)	29	29	30	45	60
フック種類	24t	24t	24t	24t	24t
フック質量 (t)	0.88	0.88	0.88	0.88	0.88
掛数	2	2	2	2	2

HD性能 40mブーム+4.4m+31mヘビーリフトジブ

オフセット	10°	20°	30°	45°	60°
作業半径 (m)	荷重 (ton)	荷重 (ton)	荷重 (ton)	荷重 (ton)	荷重 (ton)
16.0	14.0				
18.0	14.0				
20.0	14.0	14.0			
22.0	14.0	14.0			
24.0	14.0	14.0	14.0		
26.0	14.0	14.0	14.0		
28.0	14.0	14.0	14.0		
30.0	14.0	14.0	14.0	13.4	
32.0	14.0	14.0	14.0	13.2	
34.0	14.0	14.0	14.0	13.0	10.5
36.0	14.0	14.0	14.0	12.8	10.5
38.0	12.5	13.9	14.0	12.7	10.4
40.0	11.0	12.3	13.6	12.5	10.4
42.0	9.7	11.0	12.1	12.4	10.3
44.0	8.6	9.7	10.7	12.1	10.3
46.0	7.5	8.6	9.5	10.7	10.3
48.0	6.5	7.5	8.4	9.4	10.0
50.0	5.6	6.5	7.3	8.2	8.7
55.0	3.7	4.4	5.0	5.6	
60.0			3.0	3.3	
危険角度 (°)	41	43	43	45	60
フック種類	24t	24t	24t	24t	24t
フック質量 (t)	0.88	0.88	0.88	0.88	0.88
掛数	2	2	2	2	2

HD性能 45mブーム+4.4m+31mヘビーリフトジブ

オフセット	10°	20°	30°	45°	60°
作業半径 (m)	荷重 (ton)	荷重 (ton)	荷重 (ton)	荷重 (ton)	荷重 (ton)
16.0	12.0				
18.0	12.0				
20.0	12.0	12.0			
22.0	12.0	12.0			
24.0	12.0	12.0			
26.0	12.0	12.0	12.0		
28.0	12.0	12.0	12.0		
30.0	12.0	12.0	12.0	11.5	
32.0	12.0	12.0	12.0	11.3	
34.0	12.0	12.0	12.0	11.2	9.0
36.0	12.0	12.0	12.0	11.0	8.9
38.0	12.0	12.0	12.0	10.9	8.9
40.0	10.7	12.0	12.0	10.8	8.8
42.0	9.4	10.7	11.9	10.7	8.8
44.0	8.2	9.4	10.5	10.6	8.8
46.0	7.2	8.3	9.3	10.6	8.8
48.0	6.2	7.2	8.2	9.3	8.8
50.0	5.3	6.3	7.1	8.1	8.7
55.0	3.3	4.1	4.8	5.6	
60.0			2.9	3.3	
危険角度 (°)	46	48	48	50	60
フック種類	24t	24t	24t	24t	24t
フック質量 (t)	0.88	0.88	0.88	0.88	0.88
掛数	2	2	2	2	2

HD性能 50mブーム+4.4m+31mヘビーリフトジブ

オフセット	10°	20°	30°	45°	60°
作業半径 (m)	荷重 (ton)	荷重 (ton)	荷重 (ton)	荷重 (ton)	荷重 (ton)
16.0	9.0				
18.0	9.0				
20.0	9.0				
22.0	9.0	9.0			
24.0	9.0	9.0			
26.0	9.0	9.0	8.4		
28.0	9.0	9.0	8.2		
30.0	9.0	9.0	8.0		
32.0	9.0	9.0	7.8	6.3	
34.0	9.0	8.8	7.7	6.2	
36.0	9.0	8.6	7.5	6.1	4.7
38.0	9.0	8.4	7.4	6.0	4.7
40.0	9.0	8.3	7.3	6.0	4.7
42.0	9.0	8.1	7.2	5.9	4.7
44.0	7.9	8.0	7.2	5.9	4.7
46.0	6.8	7.9	7.1	5.9	4.7
48.0	5.9	7.0	7.1	5.9	4.7
50.0	5.0	6.0	6.9	5.9	4.7
55.0	3.0	3.9	4.6	5.5	4.7
60.0			2.7	3.3	
危険角度 (°)	50	52	52	53	60
フック種類	24t	24t	24t	24t	24t
フック質量 (t)	0.88	0.88	0.88	0.88	0.88
掛数	2	2	2	2	2

HD性能 53.9mブーム+4.4m+31mヘビーリフトジブ

オフセット	10°	20°	30°	45°	60°
作業半径 (m)	荷重 (ton)	荷重 (ton)	荷重 (ton)	荷重 (ton)	荷重 (ton)
18.0	8.0				
20.0	8.0				
22.0	8.0	7.5			
24.0	8.0	7.2			
26.0	8.0	7.0	6.0		
28.0	8.0	6.8	5.8		
30.0	7.8	6.7	5.7		
32.0	7.6	6.5	5.6	4.3	
34.0	7.4	6.4	5.5	4.2	
36.0	7.2	6.2	5.4	4.2	3.1
38.0	7.0	6.1	5.3	4.1	3.1
40.0	6.9	6.0	5.2	4.1	3.1
42.0	6.7	5.9	5.1	4.1	3.1
44.0	6.6	5.8	5.1	4.1	3.1
46.0	6.5	5.8	5.1	4.1	3.1
48.0	5.6	5.7	5.0	4.1	3.1
50.0	4.7	5.7	5.0	4.1	3.1
55.0	2.8	3.7	4.5	4.1	3.1
60.0				3.3	
危険角度 (°)	52	54	56	56	60
フック種類	24t	24t	24t	24t	24t
フック質量 (t)	0.88	0.88	0.88	0.88	0.88
掛数	2	2	2	2	2

HE性能 14.4mブーム+4.4m+31mヘビーリフトジブ

オフセット	10°	20°	30°	45°	60°
作業半径 (m)	荷重 (ton)	荷重 (ton)	荷重 (ton)	荷重 (ton)	荷重 (ton)
11.0	35.0				
12.0	35.0				
14.0	35.0				
16.0	34.5	34.1			
18.0	34.5	33.8			
20.0	34.5	31.6			
22.0	33.1	29.2	26.1		
24.0	29.5	27.1	24.5		
26.0	26.3	25.4	23.1	19.7	
28.0	23.7	23.8	21.8	18.8	
30.0	21.4	22.4	20.7	18.0	13.1
32.0	19.3	20.3	19.7	17.3	12.8
34.0	17.6	18.4	18.9	16.7	12.5
36.0	16.0	16.7	17.4	16.2	12.3
38.0	14.6	15.2	15.8	15.8	12.2
40.0	13.3	13.8	14.3	14.9	
42.0	12.2	12.6	13.0	13.4	
44.0	11.1	11.5	11.7		
46.0	10.2	10.4			
危険角度 (°)	10	20	30	45	60
フック種類	83t	83t	83t	83t	83t
フック質量 (t)	1.00	1.00	1.00	1.00	1.00
掛数	4	4	4	4	4

HE性能 19.55mブーム+4.4m+31mヘビーリフトジブ

オフセット	10°	20°	30°	45°	60°
作業半径 (m)	荷重 (ton)	荷重 (ton)	荷重 (ton)	荷重 (ton)	荷重 (ton)
12.0	34.0				
14.0	34.0				
16.0	34.0				
18.0	34.0	34.0			
20.0	34.0	33.0			
22.0	31.3	30.6	26.8		
24.0	27.6	28.6	25.2		
26.0	24.4	26.1	23.9		
28.0	21.7	23.3	22.7	19.8	
30.0	19.4	20.8	21.6	19.0	
32.0	17.4	18.6	19.8	18.4	14.0
34.0	15.6	16.7	17.8	17.8	13.7
36.0	14.0	15.0	16.0	17.1	13.5
38.0	12.6	13.5	14.3	15.4	13.3
40.0	11.3	12.1	12.8	13.8	13.3
42.0	10.1	10.8	11.5	12.3	
44.0	9.1	9.7	10.2	10.8	
46.0	8.1	8.6	9.1	9.4	
48.0	7.2	7.6	7.9		
50.0	6.4	6.7			
危険角度 (°)	10	20	30	45	60
フック種類	83t	83t	83t	83t	83t
フック質量 (t)	1.00	1.00	1.00	1.00	1.00
掛数	4	4	4	4	4

HE性能 23.6mブーム+4.4m+31mヘビーリフトジブ

オフセット	10°	20°	30°	45°	60°
作業半径 (m)	荷重 (ton)	荷重 (ton)	荷重 (ton)	荷重 (ton)	荷重 (ton)
12.0	30.0				
14.0	30.0				
16.0	30.0				
18.0	30.0	30.0			
20.0	30.0	30.0			
22.0	30.0	30.0	27.2		
24.0	26.3	28.5	25.8		
26.0	23.1	25.1	24.4		
28.0	20.4	22.2	23.3	20.0	
30.0	18.1	19.7	21.3	19.3	
32.0	16.0	17.5	18.9	18.6	14.8
34.0	14.2	15.6	16.9	18.1	14.5
36.0	12.6	13.8	15.0	16.6	14.2
38.0	11.2	12.3	13.4	14.8	14.0
40.0	9.9	10.9	11.9	13.1	13.9
42.0	8.8	9.6	10.5	11.5	12.1
44.0	7.7	8.5	9.2	10.1	
46.0	6.7	7.4	8.1	8.7	
48.0	5.9	6.5	7.0	7.4	
50.0	5.1	5.5	5.9		
55.0	3.3	3.4			
危険角度 (°)	10	20	30	45	60
フック種類	83t	83t	83t	83t	83t
フック質量 (t)	1.00	1.00	1.00	1.00	1.00
掛数	4	4	4	4	4

HE性能 32mブーム+4.4m+31mヘビーリフトジブ

オフセット	10°	20°	30°	45°	60°
作業半径 (m)	荷重 (ton)	荷重 (ton)	荷重 (ton)	荷重 (ton)	荷重 (ton)
14.0	20.0				
16.0	20.0				
18.0	20.0				
20.0	20.0	20.0			
22.0	20.0	20.0			
24.0	20.0	20.0	19.6		
26.0	20.0	20.0	19.1		
28.0	20.0	20.0	18.6		
30.0	17.6	19.4	18.2	15.3	
32.0	15.5	17.2	17.8	15.0	
34.0	13.7	15.2	16.7	14.8	12.2
36.0	12.1	13.5	14.8	14.6	12.1
38.0	10.7	12.0	13.2	14.4	12.0
40.0	9.4	10.5	11.6	13.1	12.0
42.0	8.2	9.3	10.3	11.6	12.0
44.0	7.1	8.1	9.0	10.1	10.8
46.0	6.2	7.1	7.9	8.8	9.3
48.0	5.3	6.1	6.8	7.6	
50.0	4.4	5.2	5.8	6.5	
55.0		3.2	3.6		
危険角度 (°)	38	38	38	45	60
フック種類	24t	24t	24t	24t	24t
フック質量 (t)	0.88	0.88	0.88	0.88	0.88
掛数	2	2	2	2	2

HE性能 40mブーム+4.4m+31mヘビーリフトジブ

オフセット	10°	20°	30°	45°	60°
作業半径 (m)	荷重 (ton)	荷重 (ton)	荷重 (ton)	荷重 (ton)	荷重 (ton)
16.0	14.0				
18.0	14.0				
20.0	14.0	14.0			
22.0	14.0	14.0			
24.0	14.0	14.0	14.0		
26.0	14.0	14.0	14.0		
28.0	14.0	14.0	14.0		
30.0	14.0	14.0	14.0	13.4	
32.0	14.0	14.0	14.0	13.2	
34.0	13.1	14.0	14.0	13.0	10.5
36.0	11.5	13.0	14.0	12.8	10.5
38.0	10.0	11.5	12.8	12.7	10.4
40.0	8.7	10.0	11.3	12.5	10.4
42.0	7.6	8.8	9.9	11.4	10.3
44.0	6.5	7.6	8.7	10.0	10.3
46.0	5.5	6.6	7.5	8.7	9.4
48.0	4.6	5.6	6.5	7.5	8.1
50.0	3.8	4.7	5.5	6.4	6.8
55.0		2.7	3.3	4.0	
危険角度 (°)	47	47	49	51	60
フック種類	24t	24t	24t	24t	24t
フック質量 (t)	0.88	0.88	0.88	0.88	0.88
掛数	2	2	2	2	2

HE性能 45mブーム+4.4m+31mヘビーリフトジブ

オフセット	10°	20°	30°	45°	60°
作業半径 (m)	荷重 (ton)	荷重 (ton)	荷重 (ton)	荷重 (ton)	荷重 (ton)
16.0	12.0				
18.0	12.0				
20.0	12.0	12.0			
22.0	12.0	12.0			
24.0	12.0	12.0			
26.0	12.0	12.0	12.0		
28.0	12.0	12.0	12.0		
30.0	12.0	12.0	12.0	11.5	
32.0	12.0	12.0	12.0	11.3	
34.0	12.0	12.0	12.0	11.2	9.0
36.0	11.1	12.0	12.0	11.0	8.9
38.0	9.7	11.2	12.0	10.9	8.9
40.0	8.4	9.8	11.1	10.8	8.8
42.0	7.2	8.5	9.7	10.7	8.8
44.0	6.1	7.3	8.4	9.8	8.8
46.0	5.2	6.3	7.3	8.6	8.8
48.0	4.3	5.3	6.3	7.4	8.1
50.0	3.5	4.4	5.3	6.3	6.9
55.0			3.1	3.9	
危険角度 (°)	51	53	53	55	60
フック種類	24t	24t	24t	24t	24t
フック質量 (t)	0.88	0.88	0.88	0.88	0.88
掛数	2	2	2	2	2

HE性能 50mブーム+4.4m+31mヘビーリフトジブ

オフセット	10°	20°	30°	45°	60°
作業半径 (m)	荷重 (ton)	荷重 (ton)	荷重 (ton)	荷重 (ton)	荷重 (ton)
16.0	9.0				
18.0	9.0				
20.0	9.0				
22.0	9.0	9.0			
24.0	9.0	9.0			
26.0	9.0	9.0	8.4		
28.0	9.0	9.0	8.2		
30.0	9.0	9.0	8.0		
32.0	9.0	9.0	7.8	6.3	
34.0	9.0	8.8	7.7	6.2	
36.0	9.0	8.6	7.5	6.1	4.7
38.0	9.0	8.4	7.4	6.0	4.7
40.0	8.1	8.3	7.3	6.0	4.7
42.0	6.9	8.1	7.2	5.9	4.7
44.0	5.8	7.1	7.2	5.9	4.7
46.0	4.9	6.0	7.1	5.9	4.7
48.0	4.0	5.1	6.1	5.9	4.7
50.0	3.1	4.2	5.1	5.9	4.7
55.0			3.0	3.8	4.2
危険角度 (°)	54	56	56	58	60
フック種類	24t	24t	24t	24t	24t
フック質量 (t)	0.88	0.88	0.88	0.88	0.88
掛数	2	2	2	2	2

HE性能 53.9mブーム+4.4m+31mヘビーリフトジブ

オフセット	10°	20°	30°	45°	60°
作業半径 (m)	荷重 (ton)	荷重 (ton)	荷重 (ton)	荷重 (ton)	荷重 (ton)
18.0	8.0				
20.0	8.0				
22.0	8.0	7.5			
24.0	8.0	7.2			
26.0	8.0	7.0	6.0		
28.0	8.0	6.8	5.8		
30.0	7.8	6.7	5.7		
32.0	7.6	6.5	5.6	4.3	
34.0	7.4	6.4	5.5	4.2	
36.0	7.2	6.2	5.4	4.2	3.1
38.0	7.0	6.1	5.3	4.1	3.1
40.0	6.9	6.0	5.2	4.1	3.1
42.0	6.7	5.9	5.1	4.1	3.1
44.0	5.6	5.8	5.1	4.1	3.1
46.0	4.6	5.8	5.1	4.1	3.1
48.0	3.7	4.9	5.0	4.1	3.1
50.0	2.9	4.0	4.9	4.1	3.1
55.0			2.8	3.8	3.1
危険角度 (°)	57	58	58	59	60
フック種類	24t	24t	24t	24t	24t
フック質量 (t)	0.88	0.88	0.88	0.88	0.88
掛数	2	2	2	2	2

HF性能 14.4mブーム+4.4m+31mヘビーリフトジブ

オフセット	10°	20°	30°	45°	60°
作業半径 (m)	荷重 (ton)	荷重 (ton)	荷重 (ton)	荷重 (ton)	荷重 (ton)
11.0	35.0				
12.0	35.0				
14.0	35.0				
16.0	34.5	34.1			
18.0	34.5	33.8			
20.0	34.5	31.6			
22.0	30.6	29.2	26.1		
24.0	27.0	27.1	24.5		
26.0	23.9	24.9	23.1	19.7	
28.0	21.3	22.2	21.8	18.8	
30.0	19.1	19.9	20.7	18.0	13.1
32.0	17.2	17.9	18.6	17.3	12.8
34.0	15.6	16.2	16.8	16.7	12.5
36.0	14.1	14.7	15.2	15.9	12.3
38.0	12.8	13.3	13.8	14.4	12.2
40.0	11.7	12.1	12.5	12.9	
42.0	10.7	11.0	11.3	11.6	
44.0	9.8	10.1	10.3		
46.0	9.0	9.1			
危険角度 (°)	10	20	30	45	60
フック種類	83t	83t	83t	83t	83t
フック質量 (t)	1.00	1.00	1.00	1.00	1.00
掛数	4	4	4	4	4

HF性能 19.55mブーム+4.4m+31mヘビーリフトジブ

オフセット	10°	20°	30°	45°	60°
作業半径 (m)	荷重 (ton)	荷重 (ton)	荷重 (ton)	荷重 (ton)	荷重 (ton)
12.0	34.0				
14.0	34.0				
16.0	34.0				
18.0	34.0	34.0			
20.0	33.0	33.0			
22.0	28.8	30.6	26.8		
24.0	25.2	27.0	25.2		
26.0	22.3	23.8	23.9		
28.0	19.7	21.0	22.2	19.8	
30.0	17.5	18.7	19.7	19.0	
32.0	15.6	16.6	17.6	18.4	14.0
34.0	13.9	14.9	15.7	16.9	13.7
36.0	12.4	13.4	14.1	15.1	13.5
38.0	11.1	12.0	12.7	13.5	13.3
40.0	9.9	10.7	11.4	12.1	12.5
42.0	8.8	9.5	10.1	10.8	
44.0	7.8	8.4	9.0	9.5	
46.0	6.9	7.4	7.8	8.2	
48.0	6.1	6.5	6.8		
50.0	5.3	5.6			
危険角度 (°)	10	20	30	45	60
フック種類	83t	83t	83t	83t	83t
フック質量 (t)	1.00	1.00	1.00	1.00	1.00
掛数	4	4	4	4	4

HF性能 23.6mブーム+4.4m+31mヘビーリフトジブ

オフセット	10°	20°	30°	45°	60°
作業半径 (m)	荷重 (ton)	荷重 (ton)	荷重 (ton)	荷重 (ton)	荷重 (ton)
12.0	30.0				
14.0	30.0				
16.0	30.0				
18.0	30.0	30.0			
20.0	30.0	30.0			
22.0	27.5	30.0	27.2		
24.0	24.0	26.2	25.8		
26.0	21.0	23.0	24.4		
28.0	18.4	20.2	21.6	20.0	
30.0	16.2	17.8	19.1	19.3	
32.0	14.3	15.8	16.9	18.4	14.8
34.0	12.6	13.9	15.0	16.4	14.5
36.0	11.1	12.3	13.4	14.6	14.2
38.0	9.7	10.8	11.9	13.0	13.8
40.0	8.5	9.5	10.5	11.6	12.1
42.0	7.4	8.3	9.2	10.2	10.7
44.0	6.4	7.2	8.0	8.8	
46.0	5.5	6.2	6.9	7.5	
48.0	4.7	5.3	5.8	6.3	
50.0	3.9	4.4	4.8		
危険角度 (°)	25	28	30	45	60
フック種類	83t	83t	83t	83t	83t
フック質量 (t)	1.00	1.00	1.00	1.00	1.00
掛数	4	4	4	4	4

HF性能 32mブーム+4.4m+31mヘビーリフトジブ

オフセット	10°	20°	30°	45°	60°
作業半径 (m)	荷重 (ton)	荷重 (ton)	荷重 (ton)	荷重 (ton)	荷重 (ton)
14.0	20.0				
16.0	20.0				
18.0	20.0				
20.0	20.0	20.0			
22.0	20.0	20.0			
24.0	20.0	20.0	19.6		
26.0	20.0	20.0	19.1		
28.0	18.0	20.0	18.6		
30.0	15.7	17.6	18.2	15.3	
32.0	13.8	15.5	16.8	15.0	
34.0	12.1	13.6	14.9	14.8	12.2
36.0	10.6	12.0	13.2	14.6	12.1
38.0	9.2	10.5	11.7	13.0	12.0
40.0	8.0	9.2	10.3	11.6	12.0
42.0	6.9	7.9	9.0	10.2	10.9
44.0	5.9	6.8	7.8	8.9	9.5
46.0	4.9	5.8	6.7	7.6	8.1
48.0	4.1	4.9	5.6	6.5	
50.0	3.3	4.1	4.7	5.4	
危険角度 (°)	42	44	45	45	60
フック種類	24t	24t	24t	24t	24t
フック質量 (t)	0.88	0.88	0.88	0.88	0.88
掛数	2	2	2	2	2

HF性能 40mブーム+4.4m+31mヘビーリフトジブ

オフセット	10°	20°	30°	45°	60°
作業半径 (m)	荷重 (ton)	荷重 (ton)	荷重 (ton)	荷重 (ton)	荷重 (ton)
16.0	14.0				
18.0	14.0				
20.0	14.0	14.0			
22.0	14.0	14.0			
24.0	14.0	14.0	14.0		
26.0	14.0	14.0	14.0		
28.0	14.0	14.0	14.0		
30.0	14.0	14.0	14.0	13.4	
32.0	13.2	14.0	14.0	13.2	
34.0	11.4	13.1	14.0	13.0	10.5
36.0	9.9	11.5	12.9	12.8	10.5
38.0	8.6	10.0	11.3	12.7	10.4
40.0	7.3	8.7	9.9	11.4	10.4
42.0	6.2	7.5	8.6	10.0	10.3
44.0	5.2	6.4	7.4	8.7	9.6
46.0	4.3	5.4	6.3	7.5	8.2
48.0	3.5	4.4	5.3	6.3	6.9
50.0	2.7	3.6	4.4	5.3	5.7
55.0				2.9	
危険角度 (°)	48	51	53	53	60
フック種類	24t	24t	24t	24t	24t
フック質量 (t)	0.88	0.88	0.88	0.88	0.88
掛数	2	2	2	2	2

HF性能 45mブーム+4.4m+31mヘビーリフトジブ

オフセット	10°	20°	30°	45°	60°
作業半径 (m)	荷重 (ton)	荷重 (ton)	荷重 (ton)	荷重 (ton)	荷重 (ton)
16.0	12.0				
18.0	12.0				
20.0	12.0	12.0			
22.0	12.0	12.0			
24.0	12.0	12.0			
26.0	12.0	12.0	12.0		
28.0	12.0	12.0	12.0		
30.0	12.0	12.0	12.0	11.5	
32.0	12.0	12.0	12.0	11.3	
34.0	11.1	12.0	12.0	11.2	9.0
36.0	9.6	11.2	12.0	11.0	8.9
38.0	8.2	9.7	11.1	10.9	8.9
40.0	7.0	8.4	9.7	10.8	8.8
42.0	5.9	7.2	8.4	9.9	8.8
44.0	4.9	6.1	7.2	8.6	8.8
46.0	4.0	5.1	6.1	7.4	8.2
48.0	3.1	4.2	5.1	6.2	6.9
50.0		3.3	4.2	5.2	5.8
55.0				2.9	
危険角度 (°)	55	55	57	57	60
フック種類	24t	24t	24t	24t	24t
フック質量 (t)	0.88	0.88	0.88	0.88	0.88
掛数	2	2	2	2	2

HF性能 50mブーム+4.4m+31mヘビーリフトジブ

オフセット	10°	20°	30°	45°	60°
作業半径 (m)	荷重 (ton)	荷重 (ton)	荷重 (ton)	荷重 (ton)	荷重 (ton)
16.0	9.0				
18.0	9.0				
20.0	9.0				
22.0	9.0	9.0			
24.0	9.0	9.0			
26.0	9.0	9.0	8.4		
28.0	9.0	9.0	8.2		
30.0	9.0	9.0	8.0		
32.0	9.0	9.0	7.8	6.3	
34.0	9.0	8.8	7.7	6.2	
36.0	9.0	8.6	7.5	6.1	4.7
38.0	7.9	8.4	7.4	6.0	4.7
40.0	6.7	8.1	7.3	6.0	4.7
42.0	5.6	6.9	7.2	5.9	4.7
44.0	4.6	5.8	7.0	5.9	4.7
46.0	3.6	4.8	5.9	5.9	4.7
48.0	2.8	3.9	4.9	5.9	4.7
50.0		3.1	4.0	5.1	4.7
55.0				2.8	3.2
危険角度 (°)	58	58	60	60	60
フック種類	24t	24t	24t	24t	24t
フック質量 (t)	0.88	0.88	0.88	0.88	0.88
掛数	2	2	2	2	2

HF性能 53.9mブーム+4.4m+31mヘビーリフトジブ

オフセット	10°	20°	30°	45°	60°
作業半径 (m)	荷重 (ton)	荷重 (ton)	荷重 (ton)	荷重 (ton)	荷重 (ton)
18.0	8.0				
20.0	8.0				
22.0	8.0	7.5			
24.0	8.0	7.2			
26.0	8.0	7.0	6.0		
28.0	8.0	6.8	5.8		
30.0	7.8	6.7	5.7		
32.0	7.6	6.5	5.6	4.3	
34.0	7.4	6.4	5.5	4.2	
36.0	7.2	6.2	5.4	4.2	3.1
38.0	7.0	6.1	5.3	4.1	3.1
40.0	6.4	6.0	5.2	4.1	3.1
42.0	5.3	5.9	5.1	4.1	3.1
44.0	4.3	5.6	5.1	4.1	3.1
46.0	3.4	4.6	5.1	4.1	3.1
48.0		3.7	4.8	4.1	3.1
50.0		2.9	3.8	4.1	3.1
55.0				2.8	3.1
危険角度 (°)	61	61	61	61	62
フック種類	24t	24t	24t	24t	24t
フック質量 (t)	0.88	0.88	0.88	0.88	0.88
掛数	2	2	2	2	2

HG性能 14.4mブーム+4.4m+31mヘビーリフトジブ

オフセット	10°	20°	30°	45°	60°
作業半径 (m)	荷重 (ton)	荷重 (ton)	荷重 (ton)	荷重 (ton)	荷重 (ton)
11.0	35.0				
12.0	35.0				
14.0	35.0				
16.0	34.5	34.1			
18.0	34.5	33.8			
20.0	31.8	31.6			
22.0	27.4	28.7	26.1		
24.0	23.9	25.0	24.5		
26.0	21.0	22.0	23.0	19.7	
28.0	18.6	19.5	20.4	18.8	
30.0	16.6	17.4	18.2	18.0	13.1
32.0	14.8	15.5	16.2	17.2	12.8
34.0	13.3	14.0	14.6	15.4	12.5
36.0	12.0	12.6	13.1	13.8	12.3
38.0	10.9	11.4	11.8	12.4	12.2
40.0	9.9	10.3	10.7	11.1	
42.0	9.0	9.3	9.6	9.9	
44.0	8.2	8.4	8.6		
46.0	7.4	7.6			
危険角度 (°)	10	20	30	45	60
フック種類	83t	83t	83t	83t	83t
フック質量 (t)	1.00	1.00	1.00	1.00	1.00
掛数	4	4	4	4	4

HG性能 19.55mブーム+4.4m+31mヘビーリフトジブ

オフセット	10°	20°	30°	45°	60°
作業半径 (m)	荷重 (ton)	荷重 (ton)	荷重 (ton)	荷重 (ton)	荷重 (ton)
12.0	34.0				
14.0	34.0				
16.0	34.0				
18.0	34.0	34.0			
20.0	30.2	32.2			
22.0	25.9	27.6	26.8		
24.0	22.3	23.9	25.2		
26.0	19.4	20.8	22.1		
28.0	17.0	18.3	19.4	19.8	
30.0	15.0	16.1	17.2	18.7	
32.0	13.3	14.3	15.2	16.5	14.0
34.0	11.8	12.7	13.5	14.7	13.7
36.0	10.5	11.3	12.0	13.0	13.5
38.0	9.4	10.1	10.7	11.6	12.2
40.0	8.4	9.0	9.5	10.3	10.7
42.0	7.5	8.0	8.5	9.1	
44.0	6.5	7.1	7.5	7.9	
46.0	5.7	6.2	6.5	6.9	
48.0	4.9	5.3	5.6		
50.0	4.2	4.5			
危険角度 (°)	10	20	30	45	60
フック種類	83t	83t	83t	83t	83t
フック質量 (t)	1.00	1.00	1.00	1.00	1.00
掛数	4	4	4	4	4

HG性能 23.6mブーム+4.4m+31mヘビーリフトジブ

オフセット	10°	20°	30°	45°	60°
作業半径 (m)	荷重 (ton)	荷重 (ton)	荷重 (ton)	荷重 (ton)	荷重 (ton)
12.0	30.0				
14.0	30.0				
16.0	30.0				
18.0	30.0	30.0			
20.0	29.0	30.0			
22.0	24.9	26.9	27.2		
24.0	21.3	23.1	24.8		
26.0	18.4	20.0	21.6		
28.0	16.0	17.4	18.8	20.0	
30.0	14.0	15.3	16.5	18.2	
32.0	12.3	13.4	14.5	16.1	14.8
34.0	10.8	11.8	12.8	14.2	14.5
36.0	9.5	10.4	11.3	12.5	13.5
38.0	8.3	9.2	10.0	11.0	11.8
40.0	7.1	8.1	8.8	9.7	10.3
42.0	6.1	7.0	7.7	8.5	8.9
44.0	5.2	6.0	6.7	7.4	
46.0	4.3	5.0	5.6	6.3	
48.0	3.5	4.1	4.7	5.1	
50.0		3.3	3.7		
危険角度 (°)	35	35	37	45	60
フック種類	83t	83t	83t	83t	83t
フック質量 (t)	1.00	1.00	1.00	1.00	1.00
掛数	4	4	4	4	4

HG性能 32mブーム+4.4m+31mヘビーリフトジブ

オフセット	10°	20°	30°	45°	60°
作業半径 (m)	荷重 (ton)	荷重 (ton)	荷重 (ton)	荷重 (ton)	荷重 (ton)
14.0	20.0				
16.0	20.0				
18.0	20.0				
20.0	20.0	20.0			
22.0	20.0	20.0			
24.0	20.0	20.0	19.6		
26.0	18.1	19.8	19.1		
28.0	15.7	17.2	18.6		
30.0	13.6	15.1	16.4	15.3	
32.0	11.9	13.2	14.4	15.0	
34.0	10.4	11.6	12.7	14.2	12.2
36.0	9.0	10.2	11.2	12.5	12.1
38.0	7.7	8.9	9.8	11.0	11.9
40.0	6.6	7.8	8.7	9.7	10.5
42.0	5.5	6.6	7.6	8.5	9.2
44.0	4.6	5.6	6.5	7.5	7.9
46.0	3.7	4.6	5.4	6.4	6.8
48.0	2.9	3.8	4.5	5.3	
50.0		2.9	3.6	4.3	
危険角度 (°)	46	46	48	50	60
フック種類	24t	24t	24t	24t	24t
フック質量 (t)	0.88	0.88	0.88	0.88	0.88
掛数	2	2	2	2	2

HG性能 40mブーム+4.4m+31mヘビーリフトジブ

オフセット	10°	20°	30°	45°	60°
作業半径 (m)	荷重 (ton)	荷重 (ton)	荷重 (ton)	荷重 (ton)	荷重 (ton)
16.0	14.0				
18.0	14.0				
20.0	14.0	14.0			
22.0	14.0	14.0			
24.0	14.0	14.0	14.0		
26.0	14.0	14.0	14.0		
28.0	14.0	14.0	14.0		
30.0	13.1	14.0	14.0	13.4	
32.0	11.4	12.8	14.0	13.2	
34.0	9.8	11.2	12.4	13.0	10.5
36.0	8.4	9.8	10.9	12.4	10.5
38.0	7.1	8.5	9.6	10.9	10.4
40.0	5.9	7.3	8.4	9.6	10.4
42.0	4.9	6.1	7.3	8.4	9.1
44.0	4.0	5.1	6.1	7.3	8.0
46.0	3.1	4.1	5.1	6.3	6.9
48.0		3.3	4.1	5.2	5.8
50.0			3.3	4.2	4.6
危険角度 (°)	54	56	56	59	60
フック種類	24t	24t	24t	24t	24t
フック質量 (t)	0.88	0.88	0.88	0.88	0.88
掛数	2	2	2	2	2

HG性能 45mブーム+4.4m+31mヘビーリフトジブ

オフセット	10°	20°	30°	45°	60°
作業半径 (m)	荷重 (ton)	荷重 (ton)	荷重 (ton)	荷重 (ton)	荷重 (ton)
16.0	12.0				
18.0	12.0				
20.0	12.0	12.0			
22.0	12.0	12.0			
24.0	12.0	12.0			
26.0	12.0	12.0	12.0		
28.0	12.0	12.0	12.0		
30.0	12.0	12.0	12.0	11.5	
32.0	11.1	12.0	12.0	11.3	
34.0	9.5	11.0	12.0	11.2	9.0
36.0	8.0	9.6	10.7	11.0	8.9
38.0	6.7	8.2	9.4	10.8	8.9
40.0	5.6	7.0	8.2	9.5	8.8
42.0	4.6	5.8	7.0	8.3	8.8
44.0	3.6	4.8	5.9	7.2	7.9
46.0	2.8	3.9	4.9	6.2	6.9
48.0		3.0	3.9	5.1	5.8
50.0			3.1	4.1	4.7
危険角度 (°)	57	58	58	60	62
フック種類	24t	24t	24t	24t	24t
フック質量 (t)	0.88	0.88	0.88	0.88	0.88
掛数	2	2	2	2	2

HG性能 50mブーム+4.4m+31mヘビーリフトジブ

オフセット	10°	20°	30°	45°	60°
作業半径 (m)	荷重 (ton)	荷重 (ton)	荷重 (ton)	荷重 (ton)	荷重 (ton)
16.0	9.0				
18.0	9.0				
20.0	9.0				
22.0	9.0	9.0			
24.0	9.0	9.0			
26.0	9.0	9.0	8.4		
28.0	9.0	9.0	8.2		
30.0	9.0	9.0	8.0		
32.0	9.0	9.0	7.8	6.3	
34.0	9.0	8.8	7.7	6.2	
36.0	7.7	8.6	7.5	6.1	4.7
38.0	6.4	8.0	7.4	6.0	4.7
40.0	5.3	6.7	7.3	6.0	4.7
42.0	4.2	5.6	6.8	5.9	4.7
44.0	3.3	4.6	5.7	5.9	4.7
46.0		3.6	4.7	5.9	4.7
48.0		2.7	3.7	5.0	4.7
50.0			2.9	4.0	4.7
危険角度 (°)	61	61	61	63	65
フック種類	24t	24t	24t	24t	24t
フック質量 (t)	0.88	0.88	0.88	0.88	0.88
掛数	2	2	2	2	2

HG性能 53.9mブーム+4.4m+31mヘビーリフトジブ

オフセット	10°	20°	30°	45°	60°
作業半径 (m)	荷重 (ton)	荷重 (ton)	荷重 (ton)	荷重 (ton)	荷重 (ton)
18.0	8.0				
20.0	8.0				
22.0	8.0	7.5			
24.0	8.0	7.2			
26.0	8.0	7.0	6.0		
28.0	8.0	6.8	5.8		
30.0	7.8	6.7	5.7		
32.0	7.6	6.5	5.6	4.3	
34.0	7.4	6.4	5.5	4.2	
36.0	7.2	6.2	5.4	4.2	3.1
38.0	6.2	6.1	5.3	4.1	3.1
40.0	5.0	6.0	5.2	4.1	3.1
42.0	4.0	5.4	5.1	4.1	3.1
44.0		4.4	5.1	4.1	3.1
46.0		3.4	4.5	4.1	3.1
48.0			3.6	4.1	3.1
50.0				3.9	3.1
危険角度 (°)	64	64	65	65	66
フック種類	24t	24t	24t	24t	24t
フック質量 (t)	0.88	0.88	0.88	0.88	0.88
掛数	2	2	2	2	2

HA性能 14.4mブーム+4.4m+40mヘビーリフトジブ

オフセット	10°	20°	30°	45°	60°
作業半径 (m)	荷重 (ton)	荷重 (ton)	荷重 (ton)	荷重 (ton)	荷重 (ton)
14.0	12.0				
16.0	12.0				
18.0	12.0				
20.0	12.0	12.0			
22.0	12.0	12.0			
24.0	12.0	12.0			
26.0	12.0	12.0	12.0		
28.0	12.0	12.0	12.0		
30.0	12.0	12.0	12.0		
32.0	12.0	12.0	12.0		
34.0	12.0	12.0	12.0	12.0	
36.0	12.0	12.0	12.0	11.9	
38.0	12.0	12.0	12.0	11.3	
40.0	12.0	12.0	12.0	10.8	9.5
42.0	12.0	12.0	11.5	10.3	9.3
44.0	12.0	11.7	10.9	9.9	9.1
46.0	11.8	11.1	10.4	9.6	9.0
48.0	11.2	10.5	10.0	9.3	
50.0	10.6	10.1	9.6	9.1	
55.0	9.4	9.1			
危険角度 (°)	10	20	30	45	60
フック種類	12t	12t	12t	12t	12t
フック質量 (t)	0.53	0.53	0.53	0.53	0.53
掛数	1	1	1	1	1

HA性能 19.55mブーム+4.4m+40mヘビーリフトジブ

オフセット	10°	20°	30°	45°	60°
作業半径 (m)	荷重 (ton)	荷重 (ton)	荷重 (ton)	荷重 (ton)	荷重 (ton)
16.0	12.0				
18.0	12.0				
20.0	12.0				
22.0	12.0	12.0			
24.0	12.0	12.0			
26.0	12.0	12.0			
28.0	12.0	12.0	12.0		
30.0	12.0	12.0	12.0		
32.0	12.0	12.0	12.0		
34.0	12.0	12.0	12.0	12.0	
36.0	12.0	12.0	12.0	12.0	
38.0	12.0	12.0	12.0	11.6	
40.0	12.0	12.0	12.0	11.1	10.0
42.0	12.0	12.0	12.0	10.7	9.7
44.0	12.0	12.0	11.6	10.3	9.4
46.0	12.0	12.0	11.1	10.0	9.2
48.0	12.0	11.4	10.6	9.7	9.1
50.0	11.8	10.9	10.2	9.4	9.0
55.0	10.4	9.8	9.4	9.1	
60.0	9.2	9.1			
危険角度 (°)	10	20	30	45	60
フック種類	12t	12t	12t	12t	12t
フック質量 (t)	0.53	0.53	0.53	0.53	0.53
掛数	1	1	1	1	1

HA性能 23.6mブーム+4.4m+40mヘビーリフトジブ

オフセット	10°	20°	30°	45°	60°
作業半径 (m)	荷重 (ton)	荷重 (ton)	荷重 (ton)	荷重 (ton)	荷重 (ton)
16.0	12.0				
18.0	12.0				
20.0	12.0				
22.0	12.0	12.0			
24.0	12.0	12.0			
26.0	12.0	12.0			
28.0	12.0	12.0	12.0		
30.0	12.0	12.0	12.0		
32.0	12.0	12.0	12.0		
34.0	12.0	12.0	12.0		
36.0	12.0	12.0	12.0	12.0	
38.0	12.0	12.0	12.0	11.8	
40.0	12.0	12.0	12.0	11.4	10.1
42.0	12.0	12.0	12.0	10.9	9.8
44.0	12.0	12.0	12.0	10.6	9.5
46.0	12.0	12.0	11.6	10.2	9.3
48.0	12.0	12.0	11.1	9.9	9.2
50.0	12.0	11.6	10.7	9.6	9.1
55.0	10.0	10.4	9.8	9.2	
60.0	8.1	8.5	8.8		
65.0	5.5				
危険角度 (°)	10	20	30	45	60
フック種類	12t	12t	12t	12t	12t
フック質量 (t)	0.53	0.53	0.53	0.53	0.53
掛数	1	1	1	1	1

HA性能 32mブーム+4.4m+40mヘビーリフトジブ

オフセット	10°	20°	30°	45°	60°
作業半径 (m)	荷重 (ton)	荷重 (ton)	荷重 (ton)	荷重 (ton)	荷重 (ton)
18.0	12.0				
20.0	12.0				
22.0	12.0				
24.0	12.0	12.0			
26.0	12.0	12.0			
28.0	12.0	12.0			
30.0	12.0	12.0	12.0		
32.0	12.0	12.0	12.0		
34.0	12.0	12.0	12.0		
36.0	12.0	12.0	12.0	12.0	
38.0	12.0	12.0	12.0	12.0	
40.0	12.0	12.0	12.0	11.8	
42.0	12.0	12.0	12.0	11.4	9.5
44.0	12.0	12.0	12.0	11.0	9.4
46.0	12.0	12.0	12.0	10.7	9.3
48.0	12.0	12.0	12.0	10.4	9.3
50.0	11.5	12.0	11.5	10.1	9.2
55.0	9.2	10.0	10.6	9.5	9.0
60.0	7.2	7.9	8.5	9.1	
65.0	5.6	6.1	6.5		
70.0	4.1	4.4			
危険角度 (°)	12	20	30	45	60
フック種類	12t	12t	12t	12t	12t
フック質量 (t)	0.53	0.53	0.53	0.53	0.53
掛数	1	1	1	1	1

HA性能 40mブーム+4.4m+40mヘビーリフトジブ

オフセット	10°	20°	30°	45°	60°
作業半径 (m)	荷重 (ton)	荷重 (ton)	荷重 (ton)	荷重 (ton)	荷重 (ton)
18.0	11.0				
20.0	11.0				
22.0	11.0				
24.0	11.0	11.0			
26.0	11.0	11.0			
28.0	11.0	11.0			
30.0	11.0	11.0	11.0		
32.0	11.0	11.0	11.0		
34.0	11.0	11.0	11.0		
36.0	11.0	11.0	11.0		
38.0	11.0	11.0	11.0	10.5	
40.0	11.0	11.0	11.0	10.3	
42.0	11.0	11.0	11.0	10.1	8.1
44.0	11.0	11.0	11.0	10.0	8.0
46.0	11.0	11.0	11.0	9.9	8.0
48.0	11.0	11.0	11.0	9.8	7.9
50.0	10.9	11.0	11.0	9.7	7.9
55.0	8.5	9.5	10.5	9.5	7.9
60.0	6.6	7.4	8.2	9.1	7.9
65.0	4.9	5.6	6.2	6.8	
70.0	3.5	4.0	4.4		
75.0	2.2	2.6	2.8		
危険角度 (°)	20	22	30	45	60
フック種類	12t	12t	12t	12t	12t
フック質量 (t)	0.53	0.53	0.53	0.53	0.53
掛数	1	1	1	1	1

HA性能 45mブーム+4.4m+40mヘビーリフトジブ

オフセット	10°	20°	30°	45°	60°
作業半径 (m)	荷重 (ton)	荷重 (ton)	荷重 (ton)	荷重 (ton)	荷重 (ton)
18.0	10.0				
20.0	10.0				
22.0	10.0				
24.0	10.0				
26.0	10.0	10.0			
28.0	10.0	10.0			
30.0	10.0	10.0	10.0		
32.0	10.0	10.0	10.0		
34.0	10.0	10.0	10.0		
36.0	10.0	10.0	10.0		
38.0	10.0	10.0	10.0	8.9	
40.0	10.0	10.0	10.0	8.8	
42.0	10.0	10.0	10.0	8.7	
44.0	10.0	10.0	10.0	8.5	6.8
46.0	10.0	10.0	10.0	8.4	6.7
48.0	10.0	10.0	10.0	8.3	6.7
50.0	9.8	10.0	9.9	8.3	6.7
55.0	8.0	8.8	9.5	8.1	6.7
60.0	6.2	7.1	7.7	8.1	6.7
65.0	4.5	5.3	6.0	6.7	
70.0	3.1	3.7	4.3	4.7	
75.0	1.9	2.4	2.7		
危険角度 (°)	30	32	37	45	60
フック種類	12t	12t	12t	12t	12t
フック質量 (t)	0.53	0.53	0.53	0.53	0.53
掛数	1	1	1	1	1

HA性能 50mブーム+4.4m+40mヘビーリフトジブ

オフセット	10°	20°	30°	45°	60°
作業半径 (m)	荷重 (ton)	荷重 (ton)	荷重 (ton)	荷重 (ton)	荷重 (ton)
20.0	7.0				
22.0	7.0				
24.0	7.0				
26.0	7.0	7.0			
28.0	7.0	7.0			
30.0	7.0	7.0			
32.0	7.0	7.0	6.5		
34.0	7.0	7.0	6.3		
36.0	7.0	7.0	6.2		
38.0	7.0	7.0	6.1		
40.0	7.0	6.8	5.9	4.7	
42.0	7.0	6.7	5.8	4.6	
44.0	7.0	6.5	5.7	4.5	3.4
46.0	7.0	6.4	5.6	4.5	3.4
48.0	7.0	6.3	5.5	4.4	3.3
50.0	6.9	6.2	5.5	4.4	3.3
55.0	6.6	6.0	5.3	4.3	3.3
60.0	5.3	5.8	5.2	4.3	3.3
65.0	4.2	4.7	5.1	4.3	3.3
70.0	2.8	3.5	4.0	4.3	
75.0	1.6	2.1	2.6	3.0	
危険角度 (°)	36	39	41	45	60
フック種類	12t	12t	12t	12t	12t
フック質量 (t)	0.53	0.53	0.53	0.53	0.53
掛数	1	1	1	1	1

HA性能 53.9mブーム+4.4m+40mヘビーリフトジブ

オフセット	10°	20°	30°	45°	60°
作業半径 (m)	荷重 (ton)	荷重 (ton)	荷重 (ton)	荷重 (ton)	荷重 (ton)
20.0	6.0				
22.0	6.0				
24.0	6.0				
26.0	6.0	6.0			
28.0	6.0	5.8			
30.0	6.0	5.6			
32.0	6.0	5.4	4.5		
34.0	6.0	5.2	4.4		
36.0	6.0	5.1	4.3		
38.0	5.8	5.0	4.2		
40.0	5.6	4.8	4.1	3.1	
42.0	5.5	4.7	4.0	3.0	
44.0	5.4	4.6	3.9	3.0	2.1
46.0	5.2	4.5	3.9	2.9	2.1
48.0	5.1	4.5	3.8	2.9	2.1
50.0	5.0	4.4	3.8	2.9	2.1
55.0	4.8	4.2	3.7	2.9	2.1
60.0	4.1	4.1	3.6	2.9	2.1
65.0	3.1	3.6	3.6	2.9	2.1
70.0	2.1	2.6	3.0	2.9	
75.0		1.7	2.1	2.4	
危険角度 (°)	44	44	45	46	60
フック種類	12t	12t	12t	12t	12t
フック質量 (t)	0.53	0.53	0.53	0.53	0.53
掛数	1	1	1	1	1

HB性能 14.4mブーム+4.4m+40mヘビーリフトジブ

オフセット	10°	20°	30°	45°	60°
作業半径 (m)	荷重 (ton)	荷重 (ton)	荷重 (ton)	荷重 (ton)	荷重 (ton)
14.0	12.0				
16.0	12.0				
18.0	12.0				
20.0	12.0	12.0			
22.0	12.0	12.0			
24.0	12.0	12.0			
26.0	12.0	12.0	12.0		
28.0	12.0	12.0	12.0		
30.0	12.0	12.0	12.0		
32.0	12.0	12.0	12.0		
34.0	12.0	12.0	12.0	12.0	
36.0	12.0	12.0	12.0	11.9	
38.0	12.0	12.0	12.0	11.3	
40.0	12.0	12.0	12.0	10.8	9.5
42.0	12.0	12.0	11.5	10.3	9.3
44.0	12.0	11.7	10.9	9.9	9.1
46.0	11.8	11.1	10.4	9.6	9.0
48.0	11.2	10.5	10.0	9.3	
50.0	10.6	10.1	9.6	9.1	
55.0	9.4	9.1			
危険角度 (°)	10	20	30	45	60
フック種類	12t	12t	12t	12t	12t
フック質量 (t)	0.53	0.53	0.53	0.53	0.53
掛数	1	1	1	1	1

HB性能 19.55mブーム+4.4m+40mヘビーリフトジブ

オフセット	10°	20°	30°	45°	60°
作業半径 (m)	荷重 (ton)	荷重 (ton)	荷重 (ton)	荷重 (ton)	荷重 (ton)
16.0	12.0				
18.0	12.0				
20.0	12.0				
22.0	12.0	12.0			
24.0	12.0	12.0			
26.0	12.0	12.0			
28.0	12.0	12.0	12.0		
30.0	12.0	12.0	12.0		
32.0	12.0	12.0	12.0		
34.0	12.0	12.0	12.0	12.0	
36.0	12.0	12.0	12.0	12.0	
38.0	12.0	12.0	12.0	11.6	
40.0	12.0	12.0	12.0	11.1	10.0
42.0	12.0	12.0	12.0	10.7	9.7
44.0	12.0	12.0	11.6	10.3	9.4
46.0	12.0	12.0	11.1	10.0	9.2
48.0	12.0	11.4	10.6	9.7	9.1
50.0	11.8	10.9	10.2	9.4	9.0
55.0	10.1	9.8	9.4	9.1	
60.0	8.2	8.4			
危険角度 (°)	10	20	30	45	60
フック種類	12t	12t	12t	12t	12t
フック質量 (t)	0.53	0.53	0.53	0.53	0.53
掛数	1	1	1	1	1

HB性能 23.6mブーム+4.4m+40mヘビーリフトジブ

オフセット	10°	20°	30°	45°	60°
作業半径 (m)	荷重 (ton)	荷重 (ton)	荷重 (ton)	荷重 (ton)	荷重 (ton)
16.0	12.0				
18.0	12.0				
20.0	12.0				
22.0	12.0	12.0			
24.0	12.0	12.0			
26.0	12.0	12.0			
28.0	12.0	12.0	12.0		
30.0	12.0	12.0	12.0		
32.0	12.0	12.0	12.0		
34.0	12.0	12.0	12.0		
36.0	12.0	12.0	12.0	12.0	
38.0	12.0	12.0	12.0	11.8	
40.0	12.0	12.0	12.0	11.4	10.1
42.0	12.0	12.0	12.0	10.9	9.8
44.0	12.0	12.0	12.0	10.6	9.5
46.0	12.0	12.0	11.6	10.2	9.3
48.0	12.0	12.0	11.1	9.9	9.2
50.0	11.2	11.6	10.7	9.6	9.1
55.0	8.9	9.6	9.8	9.2	
60.0	7.0	7.5	7.8		
65.0	5.4				
危険角度 (°)	10	20	30	45	60
フック種類	12t	12t	12t	12t	12t
フック質量 (t)	0.53	0.53	0.53	0.53	0.53
掛数	1	1	1	1	1

HB性能 32mブーム+4.4m+40mヘビーリフトジブ

オフセット	10°	20°	30°	45°	60°
作業半径 (m)	荷重 (ton)	荷重 (ton)	荷重 (ton)	荷重 (ton)	荷重 (ton)
18.0	12.0				
20.0	12.0				
22.0	12.0				
24.0	12.0	12.0			
26.0	12.0	12.0			
28.0	12.0	12.0			
30.0	12.0	12.0	12.0		
32.0	12.0	12.0	12.0		
34.0	12.0	12.0	12.0		
36.0	12.0	12.0	12.0	12.0	
38.0	12.0	12.0	12.0	12.0	
40.0	12.0	12.0	12.0	11.8	
42.0	12.0	12.0	12.0	11.4	9.5
44.0	12.0	12.0	12.0	11.0	9.4
46.0	12.0	12.0	12.0	10.7	9.3
48.0	11.3	12.0	12.0	10.4	9.3
50.0	10.3	11.4	11.5	10.1	9.2
55.0	8.1	8.9	9.7	9.5	9.0
60.0	6.2	6.9	7.5	8.1	
65.0	4.6	5.1	5.5		
70.0	3.2	3.5			
危険角度 (°)	12	20	30	45	60
フック種類	12t	12t	12t	12t	12t
フック質量 (t)	0.53	0.53	0.53	0.53	0.53
掛数	1	1	1	1	1

HB性能 40mブーム+4.4m+40mヘビーリフトジブ

オフセット	10°	20°	30°	45°	60°
作業半径 (m)	荷重 (ton)	荷重 (ton)	荷重 (ton)	荷重 (ton)	荷重 (ton)
18.0	11.0				
20.0	11.0				
22.0	11.0				
24.0	11.0	11.0			
26.0	11.0	11.0			
28.0	11.0	11.0			
30.0	11.0	11.0	11.0		
32.0	11.0	11.0	11.0		
34.0	11.0	11.0	11.0		
36.0	11.0	11.0	11.0		
38.0	11.0	11.0	11.0	10.5	
40.0	11.0	11.0	11.0	10.3	
42.0	11.0	11.0	11.0	10.1	8.1
44.0	11.0	11.0	11.0	10.0	8.0
46.0	11.0	11.0	11.0	9.9	8.0
48.0	10.7	11.0	11.0	9.8	7.9
50.0	9.6	10.8	11.0	9.7	7.9
55.0	7.4	8.4	9.4	9.5	7.9
60.0	5.6	6.4	7.2	8.1	7.9
65.0	4.0	4.7	5.2	5.9	
70.0	2.6	3.1	3.5		
75.0		1.8	2.0		
危険角度 (°)	31	31	33	45	60
フック種類	12t	12t	12t	12t	12t
フック質量 (t)	0.53	0.53	0.53	0.53	0.53
掛数	1	1	1	1	1

HB性能 45mブーム+4.4m+40mヘビーリフトジブ

オフセット	10°	20°	30°	45°	60°
作業半径 (m)	荷重 (ton)	荷重 (ton)	荷重 (ton)	荷重 (ton)	荷重 (ton)
18.0	10.0				
20.0	10.0				
22.0	10.0				
24.0	10.0				
26.0	10.0	10.0			
28.0	10.0	10.0			
30.0	10.0	10.0	10.0		
32.0	10.0	10.0	10.0		
34.0	10.0	10.0	10.0		
36.0	10.0	10.0	10.0		
38.0	10.0	10.0	10.0	8.9	
40.0	10.0	10.0	10.0	8.8	
42.0	10.0	10.0	10.0	8.7	
44.0	10.0	10.0	10.0	8.5	6.8
46.0	10.0	10.0	10.0	8.4	6.7
48.0	10.0	10.0	10.0	8.3	6.7
50.0	9.3	10.0	9.9	8.3	6.7
55.0	7.0	8.1	9.1	8.1	6.7
60.0	5.2	6.1	6.9	8.0	6.7
65.0	3.6	4.4	5.1	5.8	
70.0	2.3	2.9	3.4	3.9	
75.0			1.9		
危険角度 (°)	37	40	40	45	60
フック種類	12t	12t	12t	12t	12t
フック質量 (t)	0.53	0.53	0.53	0.53	0.53
掛数	1	1	1	1	1

HB性能 50mブーム+4.4m+40mヘビーリフトジブ

オフセット	10°	20°	30°	45°	60°
作業半径 (m)	荷重 (ton)	荷重 (ton)	荷重 (ton)	荷重 (ton)	荷重 (ton)
20.0	7.0				
22.0	7.0				
24.0	7.0				
26.0	7.0	7.0			
28.0	7.0	7.0			
30.0	7.0	7.0			
32.0	7.0	7.0	6.5		
34.0	7.0	7.0	6.3		
36.0	7.0	7.0	6.2		
38.0	7.0	7.0	6.1		
40.0	7.0	6.8	5.9	4.7	
42.0	7.0	6.7	5.8	4.6	
44.0	7.0	6.5	5.7	4.5	3.4
46.0	7.0	6.4	5.6	4.5	3.4
48.0	7.0	6.3	5.5	4.4	3.3
50.0	6.9	6.2	5.5	4.4	3.3
55.0	6.6	6.0	5.3	4.3	3.3
60.0	4.8	5.8	5.2	4.3	3.3
65.0	3.3	4.1	4.9	4.3	3.3
70.0	1.9	2.6	3.2	3.9	
75.0			1.8	2.1	
危険角度 (°)	42	45	45	46	60
フック種類	12t	12t	12t	12t	12t
フック質量 (t)	0.53	0.53	0.53	0.53	0.53
掛数	1	1	1	1	1

HB性能 53.9mブーム+4.4m+40mヘビーリフトジブ

オフセット	10°	20°	30°	45°	60°
作業半径 (m)	荷重 (ton)	荷重 (ton)	荷重 (ton)	荷重 (ton)	荷重 (ton)
20.0	6.0				
22.0	6.0				
24.0	6.0				
26.0	6.0	6.0			
28.0	6.0	5.8			
30.0	6.0	5.6			
32.0	6.0	5.4	4.5		
34.0	6.0	5.2	4.4		
36.0	6.0	5.1	4.3		
38.0	5.8	5.0	4.2		
40.0	5.6	4.8	4.1	3.1	
42.0	5.5	4.7	4.0	3.0	
44.0	5.4	4.6	3.9	3.0	2.1
46.0	5.2	4.5	3.9	2.9	2.1
48.0	5.1	4.5	3.8	2.9	2.1
50.0	5.0	4.4	3.8	2.9	2.1
55.0	4.8	4.2	3.7	2.9	2.1
60.0	4.1	4.1	3.6	2.9	2.1
65.0	3.0	3.6	3.6	2.9	2.1
70.0	1.7	2.4	3.0	2.9	
75.0			1.7	2.1	
危険角度 (°)	46	47	47	48	60
フック種類	12t	12t	12t	12t	12t
フック質量 (t)	0.53	0.53	0.53	0.53	0.53
掛数	1	1	1	1	1

HC性能 14.4mブーム+4.4m+40mヘビーリフトジブ

オフセット	10°	20°	30°	45°	60°
作業半径 (m)	荷重 (ton)	荷重 (ton)	荷重 (ton)	荷重 (ton)	荷重 (ton)
14.0	12.0				
16.0	12.0				
18.0	12.0				
20.0	12.0	12.0			
22.0	12.0	12.0			
24.0	12.0	12.0			
26.0	12.0	12.0	12.0		
28.0	12.0	12.0	12.0		
30.0	12.0	12.0	12.0		
32.0	12.0	12.0	12.0		
34.0	12.0	12.0	12.0	12.0	
36.0	12.0	12.0	12.0	11.9	
38.0	12.0	12.0	12.0	11.3	
40.0	12.0	12.0	12.0	10.8	9.5
42.0	12.0	12.0	11.5	10.3	9.3
44.0	12.0	11.7	10.9	9.9	9.1
46.0	11.8	11.1	10.4	9.6	9.0
48.0	11.2	10.5	10.0	9.3	
50.0	10.6	10.1	9.6	9.1	
55.0	9.4	9.1			
危険角度 (°)	10	20	30	45	60
フック種類	12t	12t	12t	12t	12t
フック質量 (t)	0.53	0.53	0.53	0.53	0.53
掛数	1	1	1	1	1

HC性能 19.55mブーム+4.4m+40mヘビーリフトジブ

オフセット	10°	20°	30°	45°	60°
作業半径 (m)	荷重 (ton)	荷重 (ton)	荷重 (ton)	荷重 (ton)	荷重 (ton)
16.0	12.0				
18.0	12.0				
20.0	12.0				
22.0	12.0	12.0			
24.0	12.0	12.0			
26.0	12.0	12.0			
28.0	12.0	12.0	12.0		
30.0	12.0	12.0	12.0		
32.0	12.0	12.0	12.0		
34.0	12.0	12.0	12.0	12.0	
36.0	12.0	12.0	12.0	12.0	
38.0	12.0	12.0	12.0	11.6	
40.0	12.0	12.0	12.0	11.1	10.0
42.0	12.0	12.0	12.0	10.7	9.7
44.0	12.0	12.0	11.6	10.3	9.4
46.0	12.0	12.0	11.1	10.0	9.2
48.0	12.0	11.4	10.6	9.7	9.1
50.0	11.1	10.9	10.2	9.4	9.0
55.0	9.0	9.5	9.4	9.1	
60.0	7.2	7.4			
危険角度 (°)	10	20	30	45	60
フック種類	12t	12t	12t	12t	12t
フック質量 (t)	0.53	0.53	0.53	0.53	0.53
掛数	1	1	1	1	1

HC性能 23.6mブーム+4.4m+40mヘビーリフトジブ

オフセット	10°	20°	30°	45°	60°
作業半径 (m)	荷重 (ton)	荷重 (ton)	荷重 (ton)	荷重 (ton)	荷重 (ton)
16.0	12.0				
18.0	12.0				
20.0	12.0				
22.0	12.0	12.0			
24.0	12.0	12.0			
26.0	12.0	12.0			
28.0	12.0	12.0	12.0		
30.0	12.0	12.0	12.0		
32.0	12.0	12.0	12.0		
34.0	12.0	12.0	12.0		
36.0	12.0	12.0	12.0	12.0	
38.0	12.0	12.0	12.0	11.8	
40.0	12.0	12.0	12.0	11.4	10.1
42.0	12.0	12.0	12.0	10.9	9.8
44.0	12.0	12.0	12.0	10.6	9.5
46.0	12.0	12.0	11.6	10.2	9.3
48.0	10.9	11.9	11.1	9.9	9.2
50.0	9.9	10.8	10.7	9.6	9.1
55.0	7.8	8.5	9.1	9.2	
60.0	6.0	6.5	6.8		
65.0	4.4				
危険角度 (°)	10	20	30	45	60
フック種類	12t	12t	12t	12t	12t
フック質量 (t)	0.53	0.53	0.53	0.53	0.53
掛数	1	1	1	1	1

HC性能 32mブーム+4.4m+40mヘビーリフトジブ

オフセット	10°	20°	30°	45°	60°
作業半径 (m)	荷重 (ton)	荷重 (ton)	荷重 (ton)	荷重 (ton)	荷重 (ton)
18.0	12.0				
20.0	12.0				
22.0	12.0				
24.0	12.0	12.0			
26.0	12.0	12.0			
28.0	12.0	12.0			
30.0	12.0	12.0	12.0		
32.0	12.0	12.0	12.0		
34.0	12.0	12.0	12.0		
36.0	12.0	12.0	12.0	12.0	
38.0	12.0	12.0	12.0	12.0	
40.0	12.0	12.0	12.0	11.8	
42.0	12.0	12.0	12.0	11.4	9.5
44.0	12.0	12.0	12.0	11.0	9.4
46.0	11.1	12.0	12.0	10.7	9.3
48.0	10.1	11.2	12.0	10.4	9.3
50.0	9.1	10.1	11.1	10.1	9.2
55.0	7.0	7.8	8.6	9.5	9.0
60.0	5.2	5.9	6.5	7.1	
65.0	3.7	4.2	4.6		
70.0	2.4	2.6			
危険角度 (°)	12	20	30	45	60
フック種類	12t	12t	12t	12t	12t
フック質量 (t)	0.53	0.53	0.53	0.53	0.53
掛数	1	1	1	1	1

HC性能 40mブーム+4.4m+40mヘビーリフトジブ

オフセット	10°	20°	30°	45°	60°
作業半径 (m)	荷重 (ton)	荷重 (ton)	荷重 (ton)	荷重 (ton)	荷重 (ton)
18.0	11.0				
20.0	11.0				
22.0	11.0				
24.0	11.0	11.0			
26.0	11.0	11.0			
28.0	11.0	11.0			
30.0	11.0	11.0	11.0		
32.0	11.0	11.0	11.0		
34.0	11.0	11.0	11.0		
36.0	11.0	11.0	11.0		
38.0	11.0	11.0	11.0	10.5	
40.0	11.0	11.0	11.0	10.3	
42.0	11.0	11.0	11.0	10.1	8.1
44.0	11.0	11.0	11.0	10.0	8.0
46.0	10.4	11.0	11.0	9.9	8.0
48.0	9.4	10.7	11.0	9.8	7.9
50.0	8.4	9.6	10.7	9.7	7.9
55.0	6.3	7.3	8.3	9.4	7.9
60.0	4.5	5.4	6.1	7.0	7.4
65.0	3.0	3.7	4.3	4.9	
70.0	1.7	2.3	2.7		
危険角度 (°)	34	35	36	45	60
フック種類	12t	12t	12t	12t	12t
フック質量 (t)	0.53	0.53	0.53	0.53	0.53
掛数	1	1	1	1	1

HC性能 45mブーム+4.4m+40mヘビーリフトジブ

オフセット	10°	20°	30°	45°	60°
作業半径 (m)	荷重 (ton)	荷重 (ton)	荷重 (ton)	荷重 (ton)	荷重 (ton)
18.0	10.0				
20.0	10.0				
22.0	10.0				
24.0	10.0				
26.0	10.0	10.0			
28.0	10.0	10.0			
30.0	10.0	10.0	10.0		
32.0	10.0	10.0	10.0		
34.0	10.0	10.0	10.0		
36.0	10.0	10.0	10.0		
38.0	10.0	10.0	10.0	8.9	
40.0	10.0	10.0	10.0	8.8	
42.0	10.0	10.0	10.0	8.7	
44.0	10.0	10.0	10.0	8.5	6.8
46.0	10.0	10.0	10.0	8.4	6.7
48.0	9.0	10.0	10.0	8.3	6.7
50.0	8.0	9.3	9.9	8.3	6.7
55.0	5.9	7.0	8.0	8.1	6.7
60.0	4.2	5.1	5.9	6.9	6.7
65.0	2.7	3.4	4.1	4.9	
70.0		2.0	2.5	3.0	
危険角度 (°)	43	43	44	45	60
フック種類	12t	12t	12t	12t	12t
フック質量 (t)	0.53	0.53	0.53	0.53	0.53
掛数	1	1	1	1	1

HC性能 50mブーム+4.4m+40mヘビーリフトジブ

オフセット	10°	20°	30°	45°	60°
作業半径 (m)	荷重 (ton)	荷重 (ton)	荷重 (ton)	荷重 (ton)	荷重 (ton)
20.0	7.0				
22.0	7.0				
24.0	7.0				
26.0	7.0	7.0			
28.0	7.0	7.0			
30.0	7.0	7.0			
32.0	7.0	7.0	6.5		
34.0	7.0	7.0	6.3		
36.0	7.0	7.0	6.2		
38.0	7.0	7.0	6.1		
40.0	7.0	6.8	5.9	4.7	
42.0	7.0	6.7	5.8	4.6	
44.0	7.0	6.5	5.7	4.5	3.4
46.0	7.0	6.4	5.6	4.5	3.4
48.0	7.0	6.3	5.5	4.4	3.3
50.0	6.9	6.2	5.5	4.4	3.3
55.0	5.6	6.0	5.3	4.3	3.3
60.0	3.8	4.8	5.2	4.3	3.3
65.0	2.3	3.2	3.9	4.3	3.3
70.0		1.8	2.4	3.0	
危険角度 (°)	46	47	48	49	60
フック種類	12t	12t	12t	12t	12t
フック質量 (t)	0.53	0.53	0.53	0.53	0.53
掛数	1	1	1	1	1

HC性能 53.9mブーム+4.4m+40mヘビーリフトジブ

オフセット	10°	20°	30°	45°	60°
作業半径 (m)	荷重 (ton)	荷重 (ton)	荷重 (ton)	荷重 (ton)	荷重 (ton)
20.0	6.0				
22.0	6.0				
24.0	6.0				
26.0	6.0	6.0			
28.0	6.0	5.8			
30.0	6.0	5.6			
32.0	6.0	5.4	4.5		
34.0	6.0	5.2	4.4		
36.0	6.0	5.1	4.3		
38.0	5.8	5.0	4.2		
40.0	5.6	4.8	4.1	3.1	
42.0	5.5	4.7	4.0	3.0	
44.0	5.4	4.6	3.9	3.0	2.1
46.0	5.2	4.5	3.9	2.9	2.1
48.0	5.1	4.5	3.8	2.9	2.1
50.0	5.0	4.4	3.8	2.9	2.1
55.0	4.8	4.2	3.7	2.9	2.1
60.0	3.6	4.1	3.6	2.9	2.1
65.0	2.1	3.0	3.6	2.9	2.1
70.0		1.6	2.2	2.9	
危険角度 (°)	50	50	51	52	60
フック種類	12t	12t	12t	12t	12t
フック質量 (t)	0.53	0.53	0.53	0.53	0.53
掛数	1	1	1	1	1

HD性能 14.4mブーム+4.4m+40mヘビーリフトジブ

オフセット	10°	20°	30°	45°	60°
作業半径 (m)	荷重 (ton)	荷重 (ton)	荷重 (ton)	荷重 (ton)	荷重 (ton)
14.0	12.0				
16.0	12.0				
18.0	12.0				
20.0	12.0	12.0			
22.0	12.0	12.0			
24.0	12.0	12.0			
26.0	12.0	12.0	12.0		
28.0	12.0	12.0	12.0		
30.0	12.0	12.0	12.0		
32.0	12.0	12.0	12.0		
34.0	12.0	12.0	12.0	12.0	
36.0	12.0	12.0	12.0	11.9	
38.0	12.0	12.0	12.0	11.3	
40.0	12.0	12.0	12.0	10.8	9.5
42.0	12.0	12.0	11.5	10.3	9.3
44.0	12.0	11.7	10.9	9.9	9.1
46.0	11.8	11.1	10.4	9.6	9.0
48.0	11.2	10.5	10.0	9.3	
50.0	10.6	10.1	9.6	9.1	
55.0	9.4	9.1			
危険角度 (°)	10	20	30	45	60
フック種類	12t	12t	12t	12t	12t
フック質量 (t)	0.53	0.53	0.53	0.53	0.53
掛数	1	1	1	1	1

HD性能 19.55mブーム+4.4m+40mヘビーリフトジブ

オフセット	10°	20°	30°	45°	60°
作業半径 (m)	荷重 (ton)	荷重 (ton)	荷重 (ton)	荷重 (ton)	荷重 (ton)
16.0	12.0				
18.0	12.0				
20.0	12.0				
22.0	12.0	12.0			
24.0	12.0	12.0			
26.0	12.0	12.0			
28.0	12.0	12.0	12.0		
30.0	12.0	12.0	12.0		
32.0	12.0	12.0	12.0		
34.0	12.0	12.0	12.0	12.0	
36.0	12.0	12.0	12.0	12.0	
38.0	12.0	12.0	12.0	11.6	
40.0	12.0	12.0	12.0	11.1	10.0
42.0	12.0	12.0	12.0	10.7	9.7
44.0	12.0	12.0	11.6	10.3	9.4
46.0	11.8	12.0	11.1	10.0	9.2
48.0	10.8	11.4	10.6	9.7	9.1
50.0	9.9	10.6	10.2	9.4	9.0
55.0	7.9	8.4	8.8	9.1	
60.0	6.2	6.4			
危険角度 (°)	10	20	30	45	60
フック種類	12t	12t	12t	12t	12t
フック質量 (t)	0.53	0.53	0.53	0.53	0.53
掛数	1	1	1	1	1

HD性能 23.6mブーム+4.4m+40mヘビーリフトジブ

オフセット	10°	20°	30°	45°	60°
作業半径 (m)	荷重 (ton)	荷重 (ton)	荷重 (ton)	荷重 (ton)	荷重 (ton)
16.0	12.0				
18.0	12.0				
20.0	12.0				
22.0	12.0	12.0			
24.0	12.0	12.0			
26.0	12.0	12.0			
28.0	12.0	12.0	12.0		
30.0	12.0	12.0	12.0		
32.0	12.0	12.0	12.0		
34.0	12.0	12.0	12.0		
36.0	12.0	12.0	12.0	12.0	
38.0	12.0	12.0	12.0	11.8	
40.0	12.0	12.0	12.0	11.4	10.1
42.0	12.0	12.0	12.0	10.9	9.8
44.0	11.7	12.0	12.0	10.6	9.5
46.0	10.6	11.7	11.6	10.2	9.3
48.0	9.6	10.6	11.1	9.9	9.2
50.0	8.7	9.6	10.4	9.6	9.1
55.0	6.7	7.4	8.0	8.6	
60.0	5.0	5.4	5.8		
65.0	3.5				
危険角度 (°)	10	20	30	45	60
フック種類	12t	12t	12t	12t	12t
フック質量 (t)	0.53	0.53	0.53	0.53	0.53
掛数	1	1	1	1	1

HD性能 32mブーム+4.4m+40mヘビーリフトジブ

オフセット	10°	20°	30°	45°	60°
作業半径 (m)	荷重 (ton)	荷重 (ton)	荷重 (ton)	荷重 (ton)	荷重 (ton)
18.0	12.0				
20.0	12.0				
22.0	12.0				
24.0	12.0	12.0			
26.0	12.0	12.0			
28.0	12.0	12.0			
30.0	12.0	12.0	12.0		
32.0	12.0	12.0	12.0		
34.0	12.0	12.0	12.0		
36.0	12.0	12.0	12.0	12.0	
38.0	12.0	12.0	12.0	12.0	
40.0	12.0	12.0	12.0	11.8	
42.0	12.0	12.0	12.0	11.4	9.5
44.0	10.9	12.0	12.0	11.0	9.4
46.0	9.8	11.0	12.0	10.7	9.3
48.0	8.8	9.9	11.0	10.4	9.3
50.0	7.9	8.9	9.9	10.1	9.2
55.0	5.9	6.7	7.5	8.5	9.0
60.0	4.2	4.9	5.5	6.1	
65.0	2.8	3.3	3.7		
70.0		1.8			
危険角度 (°)	27	27	30	45	60
フック種類	12t	12t	12t	12t	12t
フック質量 (t)	0.53	0.53	0.53	0.53	0.53
掛数	1	1	1	1	1

HD性能 40mブーム+4.4m+40mヘビーリフトジブ

オフセット	10°	20°	30°	45°	60°
作業半径 (m)	荷重 (ton)	荷重 (ton)	荷重 (ton)	荷重 (ton)	荷重 (ton)
18.0	11.0				
20.0	11.0				
22.0	11.0				
24.0	11.0	11.0			
26.0	11.0	11.0			
28.0	11.0	11.0			
30.0	11.0	11.0	11.0		
32.0	11.0	11.0	11.0		
34.0	11.0	11.0	11.0		
36.0	11.0	11.0	11.0		
38.0	11.0	11.0	11.0	10.5	
40.0	11.0	11.0	11.0	10.3	
42.0	11.0	11.0	11.0	10.1	8.1
44.0	10.2	11.0	11.0	10.0	8.0
46.0	9.1	10.5	11.0	9.9	8.0
48.0	8.1	9.4	10.6	9.8	7.9
50.0	7.2	8.4	9.5	9.7	7.9
55.0	5.2	6.2	7.1	8.3	7.9
60.0	3.5	4.4	5.1	6.0	6.4
65.0	2.1	2.8	3.4	4.0	
70.0			1.8		
危険角度 (°)	40	42	42	45	60
フック種類	12t	12t	12t	12t	12t
フック質量 (t)	0.53	0.53	0.53	0.53	0.53
掛数	1	1	1	1	1

HD性能 45mブーム+4.4m+40mヘビーリフトジブ

オフセット	10°	20°	30°	45°	60°
作業半径 (m)	荷重 (ton)	荷重 (ton)	荷重 (ton)	荷重 (ton)	荷重 (ton)
18.0	10.0				
20.0	10.0				
22.0	10.0				
24.0	10.0				
26.0	10.0	10.0			
28.0	10.0	10.0			
30.0	10.0	10.0	10.0		
32.0	10.0	10.0	10.0		
34.0	10.0	10.0	10.0		
36.0	10.0	10.0	10.0		
38.0	10.0	10.0	10.0	8.9	
40.0	10.0	10.0	10.0	8.8	
42.0	10.0	10.0	10.0	8.7	
44.0	9.8	10.0	10.0	8.5	6.8
46.0	8.7	10.0	10.0	8.4	6.7
48.0	7.7	9.1	10.0	8.3	6.7
50.0	6.8	8.1	9.3	8.3	6.7
55.0	4.8	5.9	6.9	8.1	6.7
60.0	3.2	4.1	4.9	5.9	6.5
65.0	1.7	2.5	3.2	3.9	
70.0			1.7	2.1	
危険角度 (°)	45	46	46	47	60
フック種類	12t	12t	12t	12t	12t
フック質量 (t)	0.53	0.53	0.53	0.53	0.53
掛数	1	1	1	1	1

HD性能 50mブーム+4.4m+40mヘビーリフトジブ

オフセット	10°	20°	30°	45°	60°
作業半径 (m)	荷重 (ton)	荷重 (ton)	荷重 (ton)	荷重 (ton)	荷重 (ton)
20.0	7.0				
22.0	7.0				
24.0	7.0				
26.0	7.0	7.0			
28.0	7.0	7.0			
30.0	7.0	7.0			
32.0	7.0	7.0	6.5		
34.0	7.0	7.0	6.3		
36.0	7.0	7.0	6.2		
38.0	7.0	7.0	6.1		
40.0	7.0	6.8	5.9	4.7	
42.0	7.0	6.7	5.8	4.6	
44.0	7.0	6.5	5.7	4.5	3.4
46.0	7.0	6.4	5.6	4.5	3.4
48.0	7.0	6.3	5.5	4.4	3.3
50.0	6.5	6.2	5.5	4.4	3.3
55.0	4.5	5.6	5.3	4.3	3.3
60.0	2.8	3.8	4.7	4.3	3.3
65.0		2.2	3.0	3.9	3.3
70.0				2.1	
危険角度 (°)	51	51	52	53	60
フック種類	12t	12t	12t	12t	12t
フック質量 (t)	0.53	0.53	0.53	0.53	0.53
掛数	1	1	1	1	1

HD性能 53.9mブーム+4.4m+40mヘビーリフトジブ

オフセット	10°	20°	30°	45°	60°
作業半径 (m)	荷重 (ton)	荷重 (ton)	荷重 (ton)	荷重 (ton)	荷重 (ton)
20.0	6.0				
22.0	6.0				
24.0	6.0				
26.0	6.0	6.0			
28.0	6.0	5.8			
30.0	6.0	5.6			
32.0	6.0	5.4	4.5		
34.0	6.0	5.2	4.4		
36.0	6.0	5.1	4.3		
38.0	5.8	5.0	4.2		
40.0	5.6	4.8	4.1	3.1	
42.0	5.5	4.7	4.0	3.0	
44.0	5.4	4.6	3.9	3.0	2.1
46.0	5.2	4.5	3.9	2.9	2.1
48.0	5.1	4.5	3.8	2.9	2.1
50.0	5.0	4.4	3.8	2.9	2.1
55.0	4.2	4.2	3.7	2.9	2.1
60.0	2.6	3.6	3.6	2.9	2.1
65.0		2.0	2.8	2.9	2.1
70.0				2.1	
危険角度 (°)	53	54	55	55	60
フック種類	12t	12t	12t	12t	12t
フック質量 (t)	0.53	0.53	0.53	0.53	0.53
掛数	1	1	1	1	1

HE性能 14.4mブーム+4.4m+40mヘビーリフトジブ

オフセット	10°	20°	30°	45°	60°
作業半径 (m)	荷重 (ton)	荷重 (ton)	荷重 (ton)	荷重 (ton)	荷重 (ton)
14.0	12.0				
16.0	12.0				
18.0	12.0				
20.0	12.0	12.0			
22.0	12.0	12.0			
24.0	12.0	12.0			
26.0	12.0	12.0	12.0		
28.0	12.0	12.0	12.0		
30.0	12.0	12.0	12.0		
32.0	12.0	12.0	12.0		
34.0	12.0	12.0	12.0	12.0	
36.0	12.0	12.0	12.0	11.9	
38.0	12.0	12.0	12.0	11.3	
40.0	12.0	12.0	12.0	10.8	9.5
42.0	12.0	12.0	11.5	10.3	9.3
44.0	12.0	11.7	10.9	9.9	9.1
46.0	11.6	11.1	10.4	9.6	9.0
48.0	10.7	10.5	10.0	9.3	
50.0	9.9	10.1	9.6	9.1	
55.0	8.0	8.2			
危険角度 (°)	10	20	30	45	60
フック種類	12t	12t	12t	12t	12t
フック質量 (t)	0.53	0.53	0.53	0.53	0.53
掛数	1	1	1	1	1

HE性能 19.55mブーム+4.4m+40mヘビーリフトジブ

オフセット	10°	20°	30°	45°	60°
作業半径 (m)	荷重 (ton)	荷重 (ton)	荷重 (ton)	荷重 (ton)	荷重 (ton)
16.0	12.0				
18.0	12.0				
20.0	12.0				
22.0	12.0	12.0			
24.0	12.0	12.0			
26.0	12.0	12.0			
28.0	12.0	12.0	12.0		
30.0	12.0	12.0	12.0		
32.0	12.0	12.0	12.0		
34.0	12.0	12.0	12.0	12.0	
36.0	12.0	12.0	12.0	12.0	
38.0	12.0	12.0	12.0	11.6	
40.0	12.0	12.0	12.0	11.1	10.0
42.0	11.9	12.0	12.0	10.7	9.7
44.0	10.8	11.7	11.6	10.3	9.4
46.0	9.8	10.7	11.1	10.0	9.2
48.0	8.9	9.7	10.4	9.7	9.1
50.0	8.1	8.8	9.4	9.4	9.0
55.0	6.3	6.7	7.1	7.5	
60.0	4.7	4.9			
危険角度 (°)	10	20	30	45	60
フック種類	12t	12t	12t	12t	12t
フック質量 (t)	0.53	0.53	0.53	0.53	0.53
掛数	1	1	1	1	1

HE性能 23.6mブーム+4.4m+40mヘビーリフトジブ

オフセット	10°	20°	30°	45°	60°
作業半径 (m)	荷重 (ton)	荷重 (ton)	荷重 (ton)	荷重 (ton)	荷重 (ton)
16.0	12.0				
18.0	12.0				
20.0	12.0				
22.0	12.0	12.0			
24.0	12.0	12.0			
26.0	12.0	12.0			
28.0	12.0	12.0	12.0		
30.0	12.0	12.0	12.0		
32.0	12.0	12.0	12.0		
34.0	12.0	12.0	12.0		
36.0	12.0	12.0	12.0	12.0	
38.0	12.0	12.0	12.0	11.8	
40.0	11.9	12.0	12.0	11.4	10.1
42.0	10.7	11.9	12.0	10.9	9.8
44.0	9.6	10.8	11.9	10.6	9.5
46.0	8.6	9.7	10.7	10.2	9.3
48.0	7.7	8.7	9.6	9.9	9.2
50.0	6.9	7.7	8.6	9.6	9.1
55.0	5.0	5.7	6.3	7.0	
60.0	3.5	3.9	4.3		
65.0	2.1				
危険角度 (°)	10	20	30	45	60
フック種類	12t	12t	12t	12t	12t
フック質量 (t)	0.53	0.53	0.53	0.53	0.53
掛数	1	1	1	1	1

HE性能 32mブーム+4.4m+40mヘビーリフトジブ

オフセット	10°	20°	30°	45°	60°
作業半径 (m)	荷重 (ton)	荷重 (ton)	荷重 (ton)	荷重 (ton)	荷重 (ton)
18.0	12.0				
20.0	12.0				
22.0	12.0				
24.0	12.0	12.0			
26.0	12.0	12.0			
28.0	12.0	12.0			
30.0	12.0	12.0	12.0		
32.0	12.0	12.0	12.0		
34.0	12.0	12.0	12.0		
36.0	12.0	12.0	12.0	12.0	
38.0	12.0	12.0	12.0	12.0	
40.0	11.1	12.0	12.0	11.8	
42.0	9.9	11.3	12.0	11.4	9.5
44.0	8.8	10.1	11.4	11.0	9.4
46.0	7.8	9.0	10.2	10.7	9.3
48.0	6.9	8.0	9.1	10.4	9.3
50.0	6.0	7.1	8.1	9.4	9.2
55.0	4.2	5.1	5.9	6.9	7.4
60.0	2.7	3.3	3.9	4.6	
65.0		1.8	2.2		
危険角度 (°)	36	36	37	45	60
フック種類	12t	12t	12t	12t	12t
フック質量 (t)	0.53	0.53	0.53	0.53	0.53
掛数	1	1	1	1	1

HE性能 40mブーム+4.4m+40mヘビーリフトジブ

オフセット	10°	20°	30°	45°	60°
作業半径 (m)	荷重 (ton)	荷重 (ton)	荷重 (ton)	荷重 (ton)	荷重 (ton)
18.0	11.0				
20.0	11.0				
22.0	11.0				
24.0	11.0	11.0			
26.0	11.0	11.0			
28.0	11.0	11.0			
30.0	11.0	11.0	11.0		
32.0	11.0	11.0	11.0		
34.0	11.0	11.0	11.0		
36.0	11.0	11.0	11.0		
38.0	11.0	11.0	11.0	10.5	
40.0	10.4	11.0	11.0	10.3	
42.0	9.2	10.8	11.0	10.1	8.1
44.0	8.1	9.6	11.0	10.0	8.0
46.0	7.1	8.5	9.8	9.9	8.0
48.0	6.2	7.5	8.7	9.8	7.9
50.0	5.4	6.6	7.7	9.2	7.9
55.0	3.5	4.5	5.5	6.7	7.4
60.0	2.0	2.8	3.6	4.5	4.9
65.0			2.0	2.6	
危険角度 (°)	46	48	48	50	60
フック種類	12t	12t	12t	12t	12t
フック質量 (t)	0.53	0.53	0.53	0.53	0.53
掛数	1	1	1	1	1

HE性能 45mブーム+4.4m+40mヘビーリフトジブ

オフセット	10°	20°	30°	45°	60°
作業半径 (m)	荷重 (ton)	荷重 (ton)	荷重 (ton)	荷重 (ton)	荷重 (ton)
18.0	10.0				
20.0	10.0				
22.0	10.0				
24.0	10.0				
26.0	10.0	10.0			
28.0	10.0	10.0			
30.0	10.0	10.0	10.0		
32.0	10.0	10.0	10.0		
34.0	10.0	10.0	10.0		
36.0	10.0	10.0	10.0		
38.0	10.0	10.0	10.0	8.9	
40.0	10.0	10.0	10.0	8.8	
42.0	8.8	10.0	10.0	8.7	
44.0	7.7	9.3	10.0	8.5	6.8
46.0	6.7	8.2	9.6	8.4	6.7
48.0	5.8	7.2	8.5	8.3	6.7
50.0	5.0	6.3	7.5	8.3	6.7
55.0	3.2	4.2	5.3	6.5	6.7
60.0	1.6	2.6	3.4	4.4	5.0
65.0			1.8	2.5	
危険角度 (°)	49	51	51	52	60
フック種類	12t	12t	12t	12t	12t
フック質量 (t)	0.53	0.53	0.53	0.53	0.53
掛数	1	1	1	1	1

HE性能 50mブーム+4.4m+40mヘビーリフトジブ

オフセット	10°	20°	30°	45°	60°
作業半径 (m)	荷重 (ton)	荷重 (ton)	荷重 (ton)	荷重 (ton)	荷重 (ton)
20.0	7.0				
22.0	7.0				
24.0	7.0				
26.0	7.0	7.0			
28.0	7.0	7.0			
30.0	7.0	7.0			
32.0	7.0	7.0	6.5		
34.0	7.0	7.0	6.3		
36.0	7.0	7.0	6.2		
38.0	7.0	7.0	6.1		
40.0	7.0	6.8	5.9	4.7	
42.0	7.0	6.7	5.8	4.6	
44.0	7.0	6.5	5.7	4.5	3.4
46.0	6.4	6.4	5.6	4.5	3.4
48.0	5.5	6.3	5.5	4.4	3.3
50.0	4.7	6.0	5.5	4.4	3.3
55.0	2.8	4.0	5.1	4.3	3.3
60.0		2.3	3.2	4.3	3.3
65.0			1.6	2.5	2.8
危険角度 (°)	55	55	55	57	60
フック種類	12t	12t	12t	12t	12t
フック質量 (t)	0.53	0.53	0.53	0.53	0.53
掛数	1	1	1	1	1

HE性能 53.9mブーム+4.4m+40mヘビーリフトジブ

オフセット	10°	20°	30°	45°	60°
作業半径 (m)	荷重 (ton)	荷重 (ton)	荷重 (ton)	荷重 (ton)	荷重 (ton)
20.0	6.0				
22.0	6.0				
24.0	6.0				
26.0	6.0	6.0			
28.0	6.0	5.8			
30.0	6.0	5.6			
32.0	6.0	5.4	4.5		
34.0	6.0	5.2	4.4		
36.0	6.0	5.1	4.3		
38.0	5.8	5.0	4.2		
40.0	5.6	4.8	4.1	3.1	
42.0	5.5	4.7	4.0	3.0	
44.0	5.4	4.6	3.9	3.0	2.1
46.0	5.2	4.5	3.9	2.9	2.1
48.0	5.1	4.5	3.8	2.9	2.1
50.0	4.4	4.4	3.8	2.9	2.1
55.0	2.6	3.8	3.7	2.9	2.1
60.0		2.1	3.0	2.9	2.1
65.0				2.4	2.1
危険角度 (°)	57	57	59	59	60
フック種類	12t	12t	12t	12t	12t
フック質量 (t)	0.53	0.53	0.53	0.53	0.53
掛数	1	1	1	1	1

HF性能 14.4mブーム+4.4m+40mヘビーリフトジブ

オフセット	10°	20°	30°	45°	60°
作業半径 (m)	荷重 (ton)	荷重 (ton)	荷重 (ton)	荷重 (ton)	荷重 (ton)
14.0	12.0				
16.0	12.0				
18.0	12.0				
20.0	12.0	12.0			
22.0	12.0	12.0			
24.0	12.0	12.0			
26.0	12.0	12.0	12.0		
28.0	12.0	12.0	12.0		
30.0	12.0	12.0	12.0		
32.0	12.0	12.0	12.0		
34.0	12.0	12.0	12.0	12.0	
36.0	12.0	12.0	12.0	11.9	
38.0	12.0	12.0	12.0	11.3	
40.0	12.0	12.0	12.0	10.8	9.5
42.0	11.8	12.0	11.5	10.3	9.3
44.0	10.9	11.4	10.9	9.9	9.1
46.0	10.1	10.5	10.4	9.6	9.0
48.0	9.3	9.7	10.0	9.3	
50.0	8.6	8.9	9.2	9.1	
55.0	7.0	7.2			
危険角度 (°)	10	20	30	45	60
フック種類	12t	12t	12t	12t	12t
フック質量 (t)	0.53	0.53	0.53	0.53	0.53
掛数	1	1	1	1	1

HF性能 19.55mブーム+4.4m+40mヘビーリフトジブ

オフセット	10°	20°	30°	45°	60°
作業半径 (m)	荷重 (ton)	荷重 (ton)	荷重 (ton)	荷重 (ton)	荷重 (ton)
16.0	12.0				
18.0	12.0				
20.0	12.0				
22.0	12.0	12.0			
24.0	12.0	12.0			
26.0	12.0	12.0			
28.0	12.0	12.0	12.0		
30.0	12.0	12.0	12.0		
32.0	12.0	12.0	12.0		
34.0	12.0	12.0	12.0	12.0	
36.0	12.0	12.0	12.0	12.0	
38.0	12.0	12.0	12.0	11.6	
40.0	11.6	12.0	12.0	11.1	10.0
42.0	10.6	11.3	12.0	10.7	9.7
44.0	9.5	10.3	11.0	10.3	9.4
46.0	8.6	9.4	10.0	10.0	9.2
48.0	7.8	8.5	9.1	9.7	9.1
50.0	7.0	7.7	8.3	8.9	9.0
55.0	5.2	5.7	6.1	6.5	
60.0	3.7	3.9			
危険角度 (°)	10	20	30	45	60
フック種類	12t	12t	12t	12t	12t
フック質量 (t)	0.53	0.53	0.53	0.53	0.53
掛数	1	1	1	1	1

HF性能 23.6mブーム+4.4m+40mヘビーリフトジブ

オフセット	10°	20°	30°	45°	60°
作業半径 (m)	荷重 (ton)	荷重 (ton)	荷重 (ton)	荷重 (ton)	荷重 (ton)
16.0	12.0				
18.0	12.0				
20.0	12.0				
22.0	12.0	12.0			
24.0	12.0	12.0			
26.0	12.0	12.0			
28.0	12.0	12.0	12.0		
30.0	12.0	12.0	12.0		
32.0	12.0	12.0	12.0		
34.0	12.0	12.0	12.0		
36.0	12.0	12.0	12.0	12.0	
38.0	11.8	12.0	12.0	11.8	
40.0	10.5	11.7	12.0	11.4	10.1
42.0	9.4	10.6	11.5	10.9	9.8
44.0	8.4	9.5	10.4	10.6	9.5
46.0	7.4	8.5	9.4	10.2	9.3
48.0	6.6	7.5	8.4	9.4	9.2
50.0	5.8	6.6	7.5	8.5	9.0
55.0	4.0	4.7	5.3	6.0	
60.0	2.6	3.0	3.3		
危険角度 (°)	18	20	30	45	60
フック種類	12t	12t	12t	12t	12t
フック質量 (t)	0.53	0.53	0.53	0.53	0.53
掛数	1	1	1	1	1

HF性能 32mブーム+4.4m+40mヘビーリフトジブ

オフセット	10°	20°	30°	45°	60°
作業半径 (m)	荷重 (ton)	荷重 (ton)	荷重 (ton)	荷重 (ton)	荷重 (ton)
18.0	12.0				
20.0	12.0				
22.0	12.0				
24.0	12.0	12.0			
26.0	12.0	12.0			
28.0	12.0	12.0			
30.0	12.0	12.0	12.0		
32.0	12.0	12.0	12.0		
34.0	12.0	12.0	12.0		
36.0	12.0	12.0	12.0	12.0	
38.0	10.9	12.0	12.0	12.0	
40.0	9.7	11.2	12.0	11.8	
42.0	8.5	10.0	11.1	11.4	9.5
44.0	7.5	8.8	10.0	11.0	9.4
46.0	6.6	7.8	9.0	10.2	9.3
48.0	5.7	6.9	7.9	9.2	9.3
50.0	4.9	6.0	7.0	8.3	9.0
55.0	3.2	4.1	4.9	5.8	6.4
60.0	1.7	2.4	3.0	3.7	
危険角度 (°)	38	41	43	45	60
フック種類	12t	12t	12t	12t	12t
フック質量 (t)	0.53	0.53	0.53	0.53	0.53
掛数	1	1	1	1	1

HF性能 40mブーム+4.4m+40mヘビーリフトジブ

オフセット	10°	20°	30°	45°	60°
作業半径 (m)	荷重 (ton)	荷重 (ton)	荷重 (ton)	荷重 (ton)	荷重 (ton)
18.0	11.0				
20.0	11.0				
22.0	11.0				
24.0	11.0	11.0			
26.0	11.0	11.0			
28.0	11.0	11.0			
30.0	11.0	11.0	11.0		
32.0	11.0	11.0	11.0		
34.0	11.0	11.0	11.0		
36.0	11.0	11.0	11.0		
38.0	10.3	11.0	11.0	10.5	
40.0	9.0	10.7	11.0	10.3	
42.0	7.9	9.4	10.8	10.1	8.1
44.0	6.8	8.3	9.7	10.0	8.0
46.0	5.9	7.3	8.6	9.9	8.0
48.0	5.0	6.3	7.5	9.1	7.9
50.0	4.3	5.5	6.6	8.1	7.9
55.0	2.5	3.5	4.5	5.7	6.4
60.0		1.9	2.7	3.6	4.0
65.0				1.7	
危険角度 (°)	49	49	51	51	60
フック種類	12t	12t	12t	12t	12t
フック質量 (t)	0.53	0.53	0.53	0.53	0.53
掛数	1	1	1	1	1

HF性能 45mブーム+4.4m+40mヘビーリフトジブ

オフセット	10°	20°	30°	45°	60°
作業半径 (m)	荷重 (ton)	荷重 (ton)	荷重 (ton)	荷重 (ton)	荷重 (ton)
18.0	10.0				
20.0	10.0				
22.0	10.0				
24.0	10.0				
26.0	10.0	10.0			
28.0	10.0	10.0			
30.0	10.0	10.0	10.0		
32.0	10.0	10.0	10.0		
34.0	10.0	10.0	10.0		
36.0	10.0	10.0	10.0		
38.0	9.9	10.0	10.0	8.9	
40.0	8.6	10.0	10.0	8.8	
42.0	7.5	9.2	10.0	8.7	
44.0	6.5	8.0	9.5	8.5	6.8
46.0	5.5	7.0	8.4	8.4	6.7
48.0	4.7	6.0	7.3	8.3	6.7
50.0	3.9	5.2	6.4	7.9	6.7
55.0	2.2	3.2	4.2	5.5	6.4
60.0		1.6	2.5	3.5	4.0
65.0				1.7	
危険角度 (°)	53	53	55	55	60
フック種類	12t	12t	12t	12t	12t
フック質量 (t)	0.53	0.53	0.53	0.53	0.53
掛数	1	1	1	1	1

HF性能 50mブーム+4.4m+40mヘビーリフトジブ

オフセット	10°	20°	30°	45°	60°
作業半径 (m)	荷重 (ton)	荷重 (ton)	荷重 (ton)	荷重 (ton)	荷重 (ton)
20.0	7.0				
22.0	7.0				
24.0	7.0				
26.0	7.0	7.0			
28.0	7.0	7.0			
30.0	7.0	7.0			
32.0	7.0	7.0	6.5		
34.0	7.0	7.0	6.3		
36.0	7.0	7.0	6.2		
38.0	7.0	7.0	6.1		
40.0	7.0	6.8	5.9	4.7	
42.0	7.0	6.7	5.8	4.6	
44.0	6.1	6.5	5.7	4.5	3.4
46.0	5.2	6.4	5.6	4.5	3.4
48.0	4.3	5.8	5.5	4.4	3.3
50.0	3.5	4.9	5.5	4.4	3.3
55.0	1.8	3.0	4.0	4.3	3.3
60.0			2.3	3.4	3.3
65.0				1.6	2.0
危険角度 (°)	56	59	59	59	60
フック種類	12t	12t	12t	12t	12t
フック質量 (t)	0.53	0.53	0.53	0.53	0.53
掛数	1	1	1	1	1

HF性能 53.9mブーム+4.4m+40mヘビーリフトジブ

オフセット	10°	20°	30°	45°	60°
作業半径 (m)	荷重 (ton)	荷重 (ton)	荷重 (ton)	荷重 (ton)	荷重 (ton)
20.0	6.0				
22.0	6.0				
24.0	6.0				
26.0	6.0	6.0			
28.0	6.0	5.8			
30.0	6.0	5.6			
32.0	6.0	5.4	4.5		
34.0	6.0	5.2	4.4		
36.0	6.0	5.1	4.3		
38.0	5.8	5.0	4.2		
40.0	5.6	4.8	4.1	3.1	
42.0	5.5	4.7	4.0	3.0	
44.0	5.4	4.6	3.9	3.0	2.1
46.0	5.0	4.5	3.9	2.9	2.1
48.0	4.1	4.5	3.8	2.9	2.1
50.0	3.3	4.4	3.8	2.9	2.1
55.0	1.6	2.8	3.7	2.9	2.1
60.0			2.1	2.9	2.1
65.0					2.0
危険角度 (°)	59	60	61	62	62
フック種類	12t	12t	12t	12t	12t
フック質量 (t)	0.53	0.53	0.53	0.53	0.53
掛数	1	1	1	1	1

HG性能 14.4mブーム+4.4m+40mヘビーリフトジブ

オフセット	10°	20°	30°	45°	60°
作業半径 (m)	荷重 (ton)	荷重 (ton)	荷重 (ton)	荷重 (ton)	荷重 (ton)
14.0	12.0				
16.0	12.0				
18.0	12.0				
20.0	12.0	12.0			
22.0	12.0	12.0			
24.0	12.0	12.0			
26.0	12.0	12.0	12.0		
28.0	12.0	12.0	12.0		
30.0	12.0	12.0	12.0		
32.0	12.0	12.0	12.0		
34.0	12.0	12.0	12.0	12.0	
36.0	12.0	12.0	12.0	11.9	
38.0	12.0	12.0	12.0	11.3	
40.0	11.0	11.6	12.0	10.8	9.5
42.0	10.1	10.7	11.2	10.3	9.3
44.0	9.3	9.8	10.2	9.9	9.1
46.0	8.5	8.9	9.4	9.6	9.0
48.0	7.8	8.2	8.6	9.0	
50.0	7.2	7.5	7.8	8.1	
55.0	5.8	5.9			
危険角度 (°)	10	20	30	45	60
フック種類	12t	12t	12t	12t	12t
フック質量 (t)	0.53	0.53	0.53	0.53	0.53
掛数	1	1	1	1	1

HG性能 19.55mブーム+4.4m+40mヘビーリフトジブ

オフセット	10°	20°	30°	45°	60°
作業半径 (m)	荷重 (ton)	荷重 (ton)	荷重 (ton)	荷重 (ton)	荷重 (ton)
16.0	12.0				
18.0	12.0				
20.0	12.0				
22.0	12.0	12.0			
24.0	12.0	12.0			
26.0	12.0	12.0			
28.0	12.0	12.0	12.0		
30.0	12.0	12.0	12.0		
32.0	12.0	12.0	12.0		
34.0	12.0	12.0	12.0	12.0	
36.0	12.0	12.0	12.0	12.0	
38.0	10.8	11.7	12.0	11.6	
40.0	9.8	10.6	11.4	11.1	10.0
42.0	8.8	9.6	10.3	10.7	9.7
44.0	8.0	8.7	9.3	10.3	9.4
46.0	7.2	7.8	8.4	9.3	9.2
48.0	6.5	7.1	7.6	8.4	8.8
50.0	5.9	6.4	6.9	7.5	7.8
55.0	4.2	4.7	5.1	5.4	
60.0	2.8	3.0			
危険角度 (°)	10	20	30	45	60
フック種類	12t	12t	12t	12t	12t
フック質量 (t)	0.53	0.53	0.53	0.53	0.53
掛数	1	1	1	1	1

HG性能 23.6mブーム+4.4m+40mヘビーリフトジブ

オフセット	10°	20°	30°	45°	60°
作業半径 (m)	荷重 (ton)	荷重 (ton)	荷重 (ton)	荷重 (ton)	荷重 (ton)
16.0	12.0				
18.0	12.0				
20.0	12.0				
22.0	12.0	12.0			
24.0	12.0	12.0			
26.0	12.0	12.0			
28.0	12.0	12.0	12.0		
30.0	12.0	12.0	12.0		
32.0	12.0	12.0	12.0		
34.0	12.0	12.0	12.0		
36.0	11.1	12.0	12.0	12.0	
38.0	9.9	11.0	12.0	11.8	
40.0	8.9	9.9	10.9	11.4	10.1
42.0	7.9	8.9	9.7	10.9	9.8
44.0	7.1	7.9	8.8	9.9	9.5
46.0	6.2	7.1	7.8	8.9	9.3
48.0	5.4	6.3	7.0	7.9	8.6
50.0	4.7	5.5	6.2	7.0	7.5
55.0	3.0	3.7	4.3	4.9	
60.0	1.6	2.1	2.4		
危険角度 (°)	22	25	30	45	60
フック種類	12t	12t	12t	12t	12t
フック質量 (t)	0.53	0.53	0.53	0.53	0.53
掛数	1	1	1	1	1

HG性能 32mブーム+4.4m+40mヘビーリフトジブ

オフセット	10°	20°	30°	45°	60°
作業半径 (m)	荷重 (ton)	荷重 (ton)	荷重 (ton)	荷重 (ton)	荷重 (ton)
18.0	12.0				
20.0	12.0				
22.0	12.0				
24.0	12.0	12.0			
26.0	12.0	12.0			
28.0	12.0	12.0			
30.0	12.0	12.0	12.0		
32.0	12.0	12.0	12.0		
34.0	11.8	12.0	12.0		
36.0	10.5	11.8	12.0	12.0	
38.0	9.3	10.5	11.7	12.0	
40.0	8.3	9.4	10.5	11.8	
42.0	7.2	8.4	9.4	10.8	9.5
44.0	6.3	7.5	8.4	9.7	9.4
46.0	5.4	6.6	7.5	8.7	9.3
48.0	4.6	5.7	6.7	7.7	8.5
50.0	3.8	4.9	5.9	6.9	7.5
55.0	2.2	3.0	3.8	4.8	5.3
60.0			2.1	2.7	
危険角度 (°)	43	47	47	47	60
フック種類	12t	12t	12t	12t	12t
フック質量 (t)	0.53	0.53	0.53	0.53	0.53
掛数	1	1	1	1	1

HG性能 40mブーム+4.4m+40mヘビーリフトジブ

オフセット	10°	20°	30°	45°	60°
作業半径 (m)	荷重 (ton)	荷重 (ton)	荷重 (ton)	荷重 (ton)	荷重 (ton)
18.0	11.0				
20.0	11.0				
22.0	11.0				
24.0	11.0	11.0			
26.0	11.0	11.0			
28.0	11.0	11.0			
30.0	11.0	11.0	11.0		
32.0	11.0	11.0	11.0		
34.0	11.0	11.0	11.0		
36.0	10.0	11.0	11.0		
38.0	8.8	10.2	11.0	10.5	
40.0	7.6	9.0	10.2	10.3	
42.0	6.5	8.0	9.1	10.1	8.1
44.0	5.6	7.0	8.1	9.5	8.0
46.0	4.7	6.1	7.2	8.5	8.0
48.0	3.9	5.2	6.4	7.6	7.9
50.0	3.1	4.3	5.5	6.7	7.5
55.0		2.5	3.5	4.6	5.4
60.0			1.7	2.7	3.1
危険角度 (°)	54	54	54	56	60
フック種類	12t	12t	12t	12t	12t
フック質量 (t)	0.53	0.53	0.53	0.53	0.53
掛数	1	1	1	1	1

HG性能 45mブーム+4.4m+40mヘビーリフトジブ

オフセット	10°	20°	30°	45°	60°
作業半径 (m)	荷重 (ton)	荷重 (ton)	荷重 (ton)	荷重 (ton)	荷重 (ton)
18.0	10.0				
20.0	10.0				
22.0	10.0				
24.0	10.0				
26.0	10.0	10.0			
28.0	10.0	10.0			
30.0	10.0	10.0	10.0		
32.0	10.0	10.0	10.0		
34.0	10.0	10.0	10.0		
36.0	9.7	10.0	10.0		
38.0	8.4	10.0	10.0	8.9	
40.0	7.2	8.8	10.0	8.8	
42.0	6.2	7.8	9.0	8.7	
44.0	5.2	6.8	7.9	8.5	6.8
46.0	4.3	5.8	7.0	8.4	6.7
48.0	3.5	4.9	6.2	7.5	6.7
50.0	2.8	4.0	5.2	6.6	6.7
55.0		2.2	3.2	4.5	5.4
60.0				2.6	3.1
危険角度 (°)	57	58	59	59	60
フック種類	12t	12t	12t	12t	12t
フック質量 (t)	0.53	0.53	0.53	0.53	0.53
掛数	1	1	1	1	1

HG性能 50mブーム+4.4m+40mヘビーリフトジブ

オフセット	10°	20°	30°	45°	60°
作業半径 (m)	荷重 (ton)	荷重 (ton)	荷重 (ton)	荷重 (ton)	荷重 (ton)
20.0	7.0				
22.0	7.0				
24.0	7.0				
26.0	7.0	7.0			
28.0	7.0	7.0			
30.0	7.0	7.0			
32.0	7.0	7.0	6.5		
34.0	7.0	7.0	6.3		
36.0	7.0	7.0	6.2		
38.0	7.0	7.0	6.1		
40.0	6.9	6.8	5.9	4.7	
42.0	5.8	6.7	5.8	4.6	
44.0	4.9	6.5	5.7	4.5	3.4
46.0	4.0	5.5	5.6	4.5	3.4
48.0	3.2	4.6	5.5	4.4	3.3
50.0	2.4	3.8	5.0	4.4	3.3
55.0			3.0	4.3	3.3
60.0				2.5	3.1
危険角度 (°)	61	62	62	63	63
フック種類	12t	12t	12t	12t	12t
フック質量 (t)	0.53	0.53	0.53	0.53	0.53
掛数	1	1	1	1	1

HG性能 53.9mブーム+4.4m+40mヘビーリフトジブ

オフセット	10°	20°	30°	45°	60°
作業半径 (m)	荷重 (ton)	荷重 (ton)	荷重 (ton)	荷重 (ton)	荷重 (ton)
20.0	6.0				
22.0	6.0				
24.0	6.0				
26.0	6.0	6.0			
28.0	6.0	5.8			
30.0	6.0	5.6			
32.0	6.0	5.4	4.5		
34.0	6.0	5.2	4.4		
36.0	6.0	5.1	4.3		
38.0	5.8	5.0	4.2		
40.0	5.6	4.8	4.1	3.1	
42.0	5.5	4.7	4.0	3.0	
44.0	4.6	4.6	3.9	3.0	2.1
46.0	3.7	4.5	3.9	2.9	2.1
48.0		4.4	3.8	2.9	2.1
50.0		3.6	3.8	2.9	2.1
55.0			2.9	2.9	2.1
60.0					2.1
危険角度 (°)	64	65	65	66	66
フック種類	12t	12t	12t	12t	12t
フック質量 (t)	0.53	0.53	0.53	0.53	0.53
掛数	1	1	1	1	1

HA性能 14.4mブーム+4.4m+47mヘビーリフトジブ

オフセット	10°	20°	30°	45°	60°
作業半径 (m)	荷重 (ton)	荷重 (ton)	荷重 (ton)	荷重 (ton)	荷重 (ton)
16.0	12.0				
18.0	12.0				
20.0	12.0				
22.0	12.0				
24.0	12.0	12.0			
26.0	12.0	12.0			
28.0	12.0	12.0			
30.0	12.0	12.0			
32.0	12.0	12.0	12.0		
34.0	12.0	12.0	12.0		
36.0	12.0	12.0	11.8		
38.0	12.0	12.0	11.1		
40.0	12.0	11.4	10.4	9.1	
42.0	11.8	10.7	9.8	8.7	
44.0	11.0	10.1	9.3	8.3	
46.0	10.3	9.5	8.8	7.9	7.2
48.0	9.7	9.0	8.4	7.6	7.0
50.0	9.1	8.5	8.0	7.3	6.8
55.0	8.0	7.6	7.2	6.7	
60.0	7.0	6.8	6.6		
危険角度 (°)	10	20	30	45	60
フック種類	12t	12t	12t	12t	12t
フック質量 (t)	0.53	0.53	0.53	0.53	0.53
掛数	1	1	1	1	1

HA性能 19.55mブーム+4.4m+47mヘビーリフトジブ

オフセット	10°	20°	30°	45°	60°
作業半径 (m)	荷重 (ton)	荷重 (ton)	荷重 (ton)	荷重 (ton)	荷重 (ton)
18.0	12.0				
20.0	12.0				
22.0	12.0				
24.0	12.0	12.0			
26.0	12.0	12.0			
28.0	12.0	12.0			
30.0	12.0	12.0			
32.0	12.0	12.0	12.0		
34.0	12.0	12.0	12.0		
36.0	12.0	12.0	12.0		
38.0	12.0	12.0	11.5		
40.0	12.0	12.0	10.9	9.3	
42.0	12.0	11.5	10.3	8.9	
44.0	12.0	10.8	9.8	8.5	
46.0	11.4	10.2	9.3	8.1	7.3
48.0	10.7	9.7	8.9	7.8	7.1
50.0	10.1	9.2	8.5	7.5	6.9
55.0	8.8	8.2	7.6	7.0	6.6
60.0	7.8	7.3	7.0	6.6	
65.0	7.0	6.7	6.6		
危険角度 (°)	10	20	30	45	60
フック種類	12t	12t	12t	12t	12t
フック質量 (t)	0.53	0.53	0.53	0.53	0.53
掛数	1	1	1	1	1

HA性能 23.6mブーム+4.4m+47mヘビーリフトジブ

オフセット	10°	20°	30°	45°	60°
作業半径 (m)	荷重 (ton)	荷重 (ton)	荷重 (ton)	荷重 (ton)	荷重 (ton)
18.0	12.0				
20.0	12.0				
22.0	12.0				
24.0	12.0				
26.0	12.0	12.0			
28.0	12.0	12.0			
30.0	12.0	12.0			
32.0	12.0	12.0	12.0		
34.0	12.0	12.0	12.0		
36.0	12.0	12.0	12.0		
38.0	12.0	12.0	11.8		
40.0	12.0	12.0	11.2	9.4	
42.0	12.0	12.0	10.6	9.0	
44.0	12.0	11.4	10.1	8.6	
46.0	12.0	10.8	9.6	8.3	7.3
48.0	11.5	10.2	9.2	8.0	7.1
50.0	10.8	9.7	8.8	7.7	7.0
55.0	9.5	8.6	8.0	7.1	6.6
60.0	8.4	7.8	7.3	6.7	
65.0	7.0	7.1	6.8	6.5	
70.0	5.5	5.8			
危険角度 (°)	10	20	30	45	60
フック種類	12t	12t	12t	12t	12t
フック質量 (t)	0.53	0.53	0.53	0.53	0.53
掛数	1	1	1	1	1

HA性能 32mブーム+4.4m+47mヘビーリフトジブ

オフセット	10°	20°	30°	45°	60°
作業半径 (m)	荷重 (ton)	荷重 (ton)	荷重 (ton)	荷重 (ton)	荷重 (ton)
20.0	12.0				
22.0	12.0				
24.0	12.0				
26.0	12.0	12.0			
28.0	12.0	12.0			
30.0	12.0	12.0			
32.0	12.0	12.0			
34.0	12.0	12.0	12.0		
36.0	12.0	12.0	12.0		
38.0	12.0	12.0	12.0		
40.0	12.0	12.0	11.8		
42.0	12.0	12.0	11.3	9.2	
44.0	12.0	12.0	10.8	8.9	
46.0	12.0	11.8	10.3	8.6	
48.0	12.0	11.3	9.8	8.3	7.2
50.0	12.0	10.7	9.4	8.0	7.1
55.0	9.8	9.6	8.6	7.5	6.7
60.0	7.8	8.6	7.9	7.0	6.5
65.0	6.1	6.9	7.3	6.7	
70.0	4.7	5.3	5.8	6.2	
75.0	3.4	3.8	4.1		
80.0	1.8				
危険角度 (°)	15	20	30	45	60
フック種類	12t	12t	12t	12t	12t
フック質量 (t)	0.53	0.53	0.53	0.53	0.53
掛数	1	1	1	1	1

HA性能 40mブーム+4.4m+47mヘビーリフトジブ

オフセット	10°	20°	30°	45°	60°
作業半径 (m)	荷重 (ton)	荷重 (ton)	荷重 (ton)	荷重 (ton)	荷重 (ton)
20.0	8.0				
22.0	8.0				
24.0	8.0				
26.0	8.0				
28.0	8.0	8.0			
30.0	8.0	8.0			
32.0	8.0	8.0			
34.0	8.0	8.0	8.0		
36.0	8.0	8.0	8.0		
38.0	8.0	8.0	8.0		
40.0	8.0	8.0	8.0		
42.0	8.0	8.0	8.0		
44.0	8.0	8.0	8.0	8.0	
46.0	8.0	8.0	8.0	8.0	
48.0	8.0	8.0	8.0	8.0	
50.0	8.0	8.0	8.0	8.0	6.3
55.0	8.0	8.0	8.0	7.7	6.2
60.0	7.1	8.0	8.0	7.3	6.1
65.0	5.4	6.3	7.1	6.9	6.1
70.0	4.0	4.7	5.4	6.1	
75.0	2.8	3.3	3.8	4.3	
80.0	1.7	2.1	2.4		
危険角度 (°)	25	28	30	45	60
フック種類	12t	12t	12t	12t	12t
フック質量 (t)	0.53	0.53	0.53	0.53	0.53
掛数	1	1	1	1	1

HA性能 45mブーム+4.4m+47mヘビーリフトジブ

オフセット	10°	20°	30°	45°	60°
作業半径 (m)	荷重 (ton)	荷重 (ton)	荷重 (ton)	荷重 (ton)	荷重 (ton)
20.0	7.5				
22.0	7.5				
24.0	7.5				
26.0	7.5				
28.0	7.5	7.5			
30.0	7.5	7.5			
32.0	7.5	7.5			
34.0	7.5	7.5			
36.0	7.5	7.5	7.5		
38.0	7.5	7.5	7.5		
40.0	7.5	7.5	7.5		
42.0	7.5	7.5	7.5		
44.0	7.5	7.5	7.5	7.1	
46.0	7.5	7.5	7.5	7.0	
48.0	7.5	7.5	7.5	6.8	
50.0	7.5	7.5	7.5	6.7	5.2
55.0	7.5	7.5	7.5	6.5	5.1
60.0	6.7	7.5	7.5	6.4	5.1
65.0	5.1	6.0	6.7	6.3	5.1
70.0	3.6	4.4	5.2	6.0	5.1
75.0	2.4	3.1	3.6	4.3	
80.0		1.8	2.3	2.6	
危険角度 (°)	38	38	40	45	60
フック種類	12t	12t	12t	12t	12t
フック質量 (t)	0.53	0.53	0.53	0.53	0.53
掛数	1	1	1	1	1

HA性能 50mブーム+4.4m+47mヘビーリフトジブ

オフセット	10°	20°	30°	45°	60°
作業半径 (m)	荷重 (ton)	荷重 (ton)	荷重 (ton)	荷重 (ton)	荷重 (ton)
22.0	5.0				
24.0	5.0				
26.0	5.0				
28.0	5.0				
30.0	5.0	5.0			
32.0	5.0	5.0			
34.0	5.0	5.0			
36.0	5.0	5.0	5.0		
38.0	5.0	5.0	4.9		
40.0	5.0	5.0	4.8		
42.0	5.0	5.0	4.6		
44.0	5.0	5.0	4.5	3.4	
46.0	5.0	5.0	4.4	3.3	
48.0	5.0	5.0	4.3	3.3	
50.0	5.0	4.9	4.2	3.2	2.2
55.0	5.0	4.7	4.1	3.1	2.2
60.0	5.0	4.5	3.9	3.1	2.2
65.0	4.2	4.4	3.9	3.0	2.2
70.0	3.3	3.8	3.8	3.0	2.2
75.0	2.0	2.8	3.3	3.0	
80.0		1.6	2.1	2.6	
危険角度 (°)	42	43	44	45	60
フック種類	12t	12t	12t	12t	12t
フック質量 (t)	0.53	0.53	0.53	0.53	0.53
掛数	1	1	1	1	1

HA性能 53.9mブーム+4.4m+47mヘビーリフトジブ

オフセット	10°	20°	30°	45°	60°
作業半径 (m)	荷重 (ton)	荷重 (ton)	荷重 (ton)	荷重 (ton)	荷重 (ton)
22.0	4.0				
24.0	4.0				
26.0	4.0				
28.0	4.0				
30.0	4.0	4.0			
32.0	4.0	4.0			
34.0	4.0	4.0			
36.0	4.0	4.0	3.3		
38.0	4.0	3.9	3.2		
40.0	4.0	3.8	3.1		
42.0	4.0	3.6	3.0		
44.0	4.0	3.5	2.9		
46.0	4.0	3.4	2.8	2.0	
48.0	4.0	3.4	2.8	1.9	
50.0	3.9	3.3	2.7	1.9	
55.0	3.6	3.1	2.6	1.8	
60.0	3.4	3.0	2.5	1.8	
65.0	3.0	2.9	2.4	1.8	
70.0	2.2	2.8	2.4	1.8	
75.0		1.9	2.4	1.8	
80.0				1.8	
危険角度 (°)	49	49	51	51	
フック種類	12t	12t	12t	12t	
フック質量 (t)	0.53	0.53	0.53	0.53	
掛数	1	1	1	1	

HB性能 14.4mブーム+4.4m+47mヘビーリフトジブ

オフセット	10°	20°	30°	45°	60°
作業半径 (m)	荷重 (ton)	荷重 (ton)	荷重 (ton)	荷重 (ton)	荷重 (ton)
16.0	12.0				
18.0	12.0				
20.0	12.0				
22.0	12.0				
24.0	12.0	12.0			
26.0	12.0	12.0			
28.0	12.0	12.0			
30.0	12.0	12.0			
32.0	12.0	12.0	12.0		
34.0	12.0	12.0	12.0		
36.0	12.0	12.0	11.8		
38.0	12.0	12.0	11.1		
40.0	12.0	11.4	10.4	9.1	
42.0	11.8	10.7	9.8	8.7	
44.0	11.0	10.1	9.3	8.3	
46.0	10.3	9.5	8.8	7.9	7.2
48.0	9.7	9.0	8.4	7.6	7.0
50.0	9.1	8.5	8.0	7.3	6.8
55.0	8.0	7.6	7.2	6.7	
60.0	7.0	6.8	6.6		
危険角度 (°)	10	20	30	45	60
フック種類	12t	12t	12t	12t	12t
フック質量 (t)	0.53	0.53	0.53	0.53	0.53
掛数	1	1	1	1	1

HB性能 19.55mブーム+4.4m+47mヘビーリフトジブ

オフセット	10°	20°	30°	45°	60°
作業半径 (m)	荷重 (ton)	荷重 (ton)	荷重 (ton)	荷重 (ton)	荷重 (ton)
18.0	12.0				
20.0	12.0				
22.0	12.0				
24.0	12.0	12.0			
26.0	12.0	12.0			
28.0	12.0	12.0			
30.0	12.0	12.0			
32.0	12.0	12.0	12.0		
34.0	12.0	12.0	12.0		
36.0	12.0	12.0	12.0		
38.0	12.0	12.0	11.5		
40.0	12.0	12.0	10.9	9.3	
42.0	12.0	11.5	10.3	8.9	
44.0	12.0	10.8	9.8	8.5	
46.0	11.4	10.2	9.3	8.1	7.3
48.0	10.7	9.7	8.9	7.8	7.1
50.0	10.1	9.2	8.5	7.5	6.9
55.0	8.8	8.2	7.6	7.0	6.6
60.0	7.8	7.3	7.0	6.6	
65.0	7.0	6.7	6.6		
危険角度 (°)	10	20	30	45	60
フック種類	12t	12t	12t	12t	12t
フック質量 (t)	0.53	0.53	0.53	0.53	0.53
掛数	1	1	1	1	1

HB性能 23.6mブーム+4.4m+47mヘビーリフトジブ

オフセット	10°	20°	30°	45°	60°
作業半径 (m)	荷重 (ton)	荷重 (ton)	荷重 (ton)	荷重 (ton)	荷重 (ton)
18.0	12.0				
20.0	12.0				
22.0	12.0				
24.0	12.0				
26.0	12.0	12.0			
28.0	12.0	12.0			
30.0	12.0	12.0			
32.0	12.0	12.0	12.0		
34.0	12.0	12.0	12.0		
36.0	12.0	12.0	12.0		
38.0	12.0	12.0	11.8		
40.0	12.0	12.0	11.2	9.4	
42.0	12.0	12.0	10.6	9.0	
44.0	12.0	11.4	10.1	8.6	
46.0	12.0	10.8	9.6	8.3	7.3
48.0	11.5	10.2	9.2	8.0	7.1
50.0	10.8	9.7	8.8	7.7	7.0
55.0	9.5	8.6	8.0	7.1	6.6
60.0	7.7	7.8	7.3	6.7	
65.0	6.1	6.6	6.8	6.5	
70.0	4.7	4.9			
危険角度 (°)	10	20	30	45	60
フック種類	12t	12t	12t	12t	12t
フック質量 (t)	0.53	0.53	0.53	0.53	0.53
掛数	1	1	1	1	1

HB性能 32mブーム+4.4m+47mヘビーリフトジブ

オフセット	10°	20°	30°	45°	60°
作業半径 (m)	荷重 (ton)	荷重 (ton)	荷重 (ton)	荷重 (ton)	荷重 (ton)
20.0	12.0				
22.0	12.0				
24.0	12.0				
26.0	12.0	12.0			
28.0	12.0	12.0			
30.0	12.0	12.0			
32.0	12.0	12.0			
34.0	12.0	12.0	12.0		
36.0	12.0	12.0	12.0		
38.0	12.0	12.0	12.0		
40.0	12.0	12.0	11.8		
42.0	12.0	12.0	11.3	9.2	
44.0	12.0	12.0	10.8	8.9	
46.0	12.0	11.8	10.3	8.6	
48.0	11.9	11.3	9.8	8.3	7.2
50.0	10.9	10.7	9.4	8.0	7.1
55.0	8.7	9.6	8.6	7.5	6.7
60.0	6.8	7.7	7.9	7.0	6.5
65.0	5.2	5.9	6.6	6.7	
70.0	3.8	4.4	4.9	5.3	
75.0	2.6	3.0	3.3		
危険角度 (°)	18	20	30	45	60
フック種類	12t	12t	12t	12t	12t
フック質量 (t)	0.53	0.53	0.53	0.53	0.53
掛数	1	1	1	1	1

HB性能 40mブーム+4.4m+47mヘビーリフトジブ

オフセット	10°	20°	30°	45°	60°
作業半径 (m)	荷重 (ton)	荷重 (ton)	荷重 (ton)	荷重 (ton)	荷重 (ton)
20.0	8.0				
22.0	8.0				
24.0	8.0				
26.0	8.0				
28.0	8.0	8.0			
30.0	8.0	8.0			
32.0	8.0	8.0			
34.0	8.0	8.0	8.0		
36.0	8.0	8.0	8.0		
38.0	8.0	8.0	8.0		
40.0	8.0	8.0	8.0		
42.0	8.0	8.0	8.0		
44.0	8.0	8.0	8.0	8.0	
46.0	8.0	8.0	8.0	8.0	
48.0	8.0	8.0	8.0	8.0	
50.0	8.0	8.0	8.0	8.0	6.3
55.0	8.0	8.0	8.0	7.7	6.2
60.0	6.1	7.1	8.0	7.3	6.1
65.0	4.5	5.4	6.2	6.9	6.1
70.0	3.1	3.9	4.5	5.3	
75.0	2.0	2.5	3.0	3.5	
80.0			1.6		
危険角度 (°)	33	37	37	45	60
フック種類	12t	12t	12t	12t	12t
フック質量 (t)	0.53	0.53	0.53	0.53	0.53
掛数	1	1	1	1	1

HB性能 45mブーム+4.4m+47mヘビーリフトジブ

オフセット	10°	20°	30°	45°	60°
作業半径 (m)	荷重 (ton)	荷重 (ton)	荷重 (ton)	荷重 (ton)	荷重 (ton)
20.0	7.5				
22.0	7.5				
24.0	7.5				
26.0	7.5				
28.0	7.5	7.5			
30.0	7.5	7.5			
32.0	7.5	7.5			
34.0	7.5	7.5			
36.0	7.5	7.5	7.5		
38.0	7.5	7.5	7.5		
40.0	7.5	7.5	7.5		
42.0	7.5	7.5	7.5		
44.0	7.5	7.5	7.5	7.1	
46.0	7.5	7.5	7.5	7.0	
48.0	7.5	7.5	7.5	6.8	
50.0	7.5	7.5	7.5	6.7	5.2
55.0	7.5	7.5	7.5	6.5	5.1
60.0	5.7	6.8	7.5	6.4	5.1
65.0	4.1	5.1	6.0	6.3	5.1
70.0	2.8	3.6	4.3	5.2	5.1
75.0	1.6	2.2	2.8	3.5	
80.0				1.8	
危険角度 (°)	40	42	44	45	60
フック種類	12t	12t	12t	12t	12t
フック質量 (t)	0.53	0.53	0.53	0.53	0.53
掛数	1	1	1	1	1

HB性能 50mブーム+4.4m+47mヘビーリフトジブ

オフセット	10°	20°	30°	45°	60°
作業半径 (m)	荷重 (ton)	荷重 (ton)	荷重 (ton)	荷重 (ton)	荷重 (ton)
22.0	5.0				
24.0	5.0				
26.0	5.0				
28.0	5.0				
30.0	5.0	5.0			
32.0	5.0	5.0			
34.0	5.0	5.0			
36.0	5.0	5.0	5.0		
38.0	5.0	5.0	4.9		
40.0	5.0	5.0	4.8		
42.0	5.0	5.0	4.6		
44.0	5.0	5.0	4.5	3.4	
46.0	5.0	5.0	4.4	3.3	
48.0	5.0	5.0	4.3	3.3	
50.0	5.0	4.9	4.2	3.2	2.2
55.0	5.0	4.7	4.1	3.1	2.2
60.0	5.0	4.5	3.9	3.1	2.2
65.0	3.8	4.4	3.9	3.0	2.2
70.0	2.4	3.3	3.8	3.0	2.2
75.0		2.0	2.6	3.0	
80.0				1.8	
危険角度 (°)	47	47	49	49	60
フック種類	12t	12t	12t	12t	12t
フック質量 (t)	0.53	0.53	0.53	0.53	0.53
掛数	1	1	1	1	1

HB性能 53.9mブーム+4.4m+47mヘビーリフトジブ

オフセット	10°	20°	30°	45°	60°
作業半径 (m)	荷重 (ton)	荷重 (ton)	荷重 (ton)	荷重 (ton)	荷重 (ton)
22.0	4.0				
24.0	4.0				
26.0	4.0				
28.0	4.0				
30.0	4.0	4.0			
32.0	4.0	4.0			
34.0	4.0	4.0			
36.0	4.0	4.0	3.3		
38.0	4.0	3.9	3.2		
40.0	4.0	3.8	3.1		
42.0	4.0	3.6	3.0		
44.0	4.0	3.5	2.9		
46.0	4.0	3.4	2.8	2.0	
48.0	4.0	3.4	2.8	1.9	
50.0	3.9	3.3	2.7	1.9	
55.0	3.6	3.1	2.6	1.8	
60.0	3.4	3.0	2.5	1.8	
65.0	3.0	2.9	2.4	1.8	
70.0	2.1	2.8	2.4	1.8	
75.0		1.8	2.4	1.8	
80.0				1.8	
危険角度 (°)	50	50	52	52	
フック種類	12t	12t	12t	12t	
フック質量 (t)	0.53	0.53	0.53	0.53	
掛数	1	1	1	1	

HC性能 14.4mブーム+4.4m+47mヘビーリフトジブ

オフセット	10°	20°	30°	45°	60°
作業半径 (m)	荷重 (ton)	荷重 (ton)	荷重 (ton)	荷重 (ton)	荷重 (ton)
16.0	12.0				
18.0	12.0				
20.0	12.0				
22.0	12.0				
24.0	12.0	12.0			
26.0	12.0	12.0			
28.0	12.0	12.0			
30.0	12.0	12.0			
32.0	12.0	12.0	12.0		
34.0	12.0	12.0	12.0		
36.0	12.0	12.0	11.8		
38.0	12.0	12.0	11.1		
40.0	12.0	11.4	10.4	9.1	
42.0	11.8	10.7	9.8	8.7	
44.0	11.0	10.1	9.3	8.3	
46.0	10.3	9.5	8.8	7.9	7.2
48.0	9.7	9.0	8.4	7.6	7.0
50.0	9.1	8.5	8.0	7.3	6.8
55.0	8.0	7.6	7.2	6.7	
60.0	7.0	6.8	6.6		
危険角度 (°)	10	20	30	45	60
フック種類	12t	12t	12t	12t	12t
フック質量 (t)	0.53	0.53	0.53	0.53	0.53
掛数	1	1	1	1	1

HC性能 19.55mブーム+4.4m+47mヘビーリフトジブ

オフセット	10°	20°	30°	45°	60°
作業半径 (m)	荷重 (ton)	荷重 (ton)	荷重 (ton)	荷重 (ton)	荷重 (ton)
18.0	12.0				
20.0	12.0				
22.0	12.0				
24.0	12.0	12.0			
26.0	12.0	12.0			
28.0	12.0	12.0			
30.0	12.0	12.0			
32.0	12.0	12.0	12.0		
34.0	12.0	12.0	12.0		
36.0	12.0	12.0	12.0		
38.0	12.0	12.0	11.5		
40.0	12.0	12.0	10.9	9.3	
42.0	12.0	11.5	10.3	8.9	
44.0	12.0	10.8	9.8	8.5	
46.0	11.4	10.2	9.3	8.1	7.3
48.0	10.7	9.7	8.9	7.8	7.1
50.0	10.1	9.2	8.5	7.5	6.9
55.0	8.8	8.2	7.6	7.0	6.6
60.0	7.8	7.3	7.0	6.6	
65.0	6.3	6.6	6.6		
危険角度 (°)	10	20	30	45	60
フック種類	12t	12t	12t	12t	12t
フック質量 (t)	0.53	0.53	0.53	0.53	0.53
掛数	1	1	1	1	1

HC性能 23.6mブーム+4.4m+47mヘビーリフトジブ

オフセット	10°	20°	30°	45°	60°
作業半径 (m)	荷重 (ton)	荷重 (ton)	荷重 (ton)	荷重 (ton)	荷重 (ton)
18.0	12.0				
20.0	12.0				
22.0	12.0				
24.0	12.0				
26.0	12.0	12.0			
28.0	12.0	12.0			
30.0	12.0	12.0			
32.0	12.0	12.0	12.0		
34.0	12.0	12.0	12.0		
36.0	12.0	12.0	12.0		
38.0	12.0	12.0	11.8		
40.0	12.0	12.0	11.2	9.4	
42.0	12.0	12.0	10.6	9.0	
44.0	12.0	11.4	10.1	8.6	
46.0	12.0	10.8	9.6	8.3	7.3
48.0	11.5	10.2	9.2	8.0	7.1
50.0	10.6	9.7	8.8	7.7	7.0
55.0	8.4	8.6	8.0	7.1	6.6
60.0	6.7	7.4	7.3	6.7	
65.0	5.1	5.6	6.1	6.5	
70.0	3.8	4.1			
危険角度 (°)	10	20	30	45	60
フック種類	12t	12t	12t	12t	12t
フック質量 (t)	0.53	0.53	0.53	0.53	0.53
掛数	1	1	1	1	1

HC性能 32mブーム+4.4m+47mヘビーリフトジブ

オフセット	10°	20°	30°	45°	60°
作業半径 (m)	荷重 (ton)	荷重 (ton)	荷重 (ton)	荷重 (ton)	荷重 (ton)
20.0	12.0				
22.0	12.0				
24.0	12.0				
26.0	12.0	12.0			
28.0	12.0	12.0			
30.0	12.0	12.0			
32.0	12.0	12.0			
34.0	12.0	12.0	12.0		
36.0	12.0	12.0	12.0		
38.0	12.0	12.0	12.0		
40.0	12.0	12.0	11.8		
42.0	12.0	12.0	11.3	9.2	
44.0	12.0	12.0	10.8	8.9	
46.0	11.7	11.8	10.3	8.6	
48.0	10.7	11.3	9.8	8.3	7.2
50.0	9.7	10.7	9.4	8.0	7.1
55.0	7.6	8.6	8.6	7.5	6.7
60.0	5.8	6.7	7.5	7.0	6.5
65.0	4.3	5.0	5.7	6.5	
70.0	3.0	3.5	4.0	4.4	
75.0	1.8	2.2	2.5		
危険角度 (°)	20	20	30	45	60
フック種類	12t	12t	12t	12t	12t
フック質量 (t)	0.53	0.53	0.53	0.53	0.53
掛数	1	1	1	1	1

HC性能 40mブーム+4.4m+47mヘビーリフトジブ

オフセット	10°	20°	30°	45°	60°
作業半径 (m)	荷重 (ton)	荷重 (ton)	荷重 (ton)	荷重 (ton)	荷重 (ton)
20.0	8.0				
22.0	8.0				
24.0	8.0				
26.0	8.0				
28.0	8.0	8.0			
30.0	8.0	8.0			
32.0	8.0	8.0			
34.0	8.0	8.0	8.0		
36.0	8.0	8.0	8.0		
38.0	8.0	8.0	8.0		
40.0	8.0	8.0	8.0		
42.0	8.0	8.0	8.0		
44.0	8.0	8.0	8.0	8.0	
46.0	8.0	8.0	8.0	8.0	
48.0	8.0	8.0	8.0	8.0	
50.0	8.0	8.0	8.0	8.0	6.3
55.0	6.9	8.0	8.0	7.7	6.2
60.0	5.1	6.1	7.1	7.3	6.1
65.0	3.6	4.5	5.3	6.3	6.1
70.0	2.3	3.0	3.7	4.4	
75.0		1.7	2.2	2.7	
危険角度 (°)	39	40	41	45	60
フック種類	12t	12t	12t	12t	12t
フック質量 (t)	0.53	0.53	0.53	0.53	0.53
掛数	1	1	1	1	1

HC性能 45mブーム+4.4m+47mヘビーリフトジブ

オフセット	10°	20°	30°	45°	60°
作業半径 (m)	荷重 (ton)	荷重 (ton)	荷重 (ton)	荷重 (ton)	荷重 (ton)
20.0	7.5				
22.0	7.5				
24.0	7.5				
26.0	7.5				
28.0	7.5	7.5			
30.0	7.5	7.5			
32.0	7.5	7.5			
34.0	7.5	7.5			
36.0	7.5	7.5	7.5		
38.0	7.5	7.5	7.5		
40.0	7.5	7.5	7.5		
42.0	7.5	7.5	7.5		
44.0	7.5	7.5	7.5	7.1	
46.0	7.5	7.5	7.5	7.0	
48.0	7.5	7.5	7.5	6.8	
50.0	7.5	7.5	7.5	6.7	5.2
55.0	6.5	7.5	7.5	6.5	5.1
60.0	4.7	5.8	6.9	6.4	5.1
65.0	3.2	4.1	5.0	6.2	5.1
70.0	1.9	2.7	3.4	4.3	4.7
75.0			2.0	2.7	
危険角度 (°)	44	48	48	48	60
フック種類	12t	12t	12t	12t	12t
フック質量 (t)	0.53	0.53	0.53	0.53	0.53
掛数	1	1	1	1	1

HC性能 50mブーム+4.4m+47mヘビーリフトジブ

オフセット	10°	20°	30°	45°	60°
作業半径 (m)	荷重 (ton)	荷重 (ton)	荷重 (ton)	荷重 (ton)	荷重 (ton)
22.0	5.0				
24.0	5.0				
26.0	5.0				
28.0	5.0				
30.0	5.0	5.0			
32.0	5.0	5.0			
34.0	5.0	5.0			
36.0	5.0	5.0	5.0		
38.0	5.0	5.0	4.9		
40.0	5.0	5.0	4.8		
42.0	5.0	5.0	4.6		
44.0	5.0	5.0	4.5	3.4	
46.0	5.0	5.0	4.4	3.3	
48.0	5.0	5.0	4.3	3.3	
50.0	5.0	4.9	4.2	3.2	2.2
55.0	5.0	4.7	4.1	3.1	2.2
60.0	4.3	4.5	3.9	3.1	2.2
65.0	2.8	3.9	3.9	3.0	2.2
70.0		2.4	3.2	3.0	2.2
75.0			1.8	2.6	
危険角度 (°)	51	51	51	52	60
フック種類	12t	12t	12t	12t	12t
フック質量 (t)	0.53	0.53	0.53	0.53	0.53
掛数	1	1	1	1	1

HC性能 53.9mブーム+4.4m+47mヘビーリフトジブ

オフセット	10°	20°	30°	45°	60°
作業半径 (m)	荷重 (ton)	荷重 (ton)	荷重 (ton)	荷重 (ton)	荷重 (ton)
22.0	4.0				
24.0	4.0				
26.0	4.0				
28.0	4.0				
30.0	4.0	4.0			
32.0	4.0	4.0			
34.0	4.0	4.0			
36.0	4.0	4.0	3.3		
38.0	4.0	3.9	3.2		
40.0	4.0	3.8	3.1		
42.0	4.0	3.6	3.0		
44.0	4.0	3.5	2.9		
46.0	4.0	3.4	2.8	2.0	
48.0	4.0	3.4	2.8	1.9	
50.0	3.9	3.3	2.7	1.9	
55.0	3.6	3.1	2.6	1.8	
60.0	3.4	3.0	2.5	1.8	
65.0	2.6	2.9	2.4	1.8	
70.0		2.2	2.4	1.8	
75.0			1.7	1.8	
危険角度 (°)	53	53	53	55	
フック種類	12t	12t	12t	12t	
フック質量 (t)	0.53	0.53	0.53	0.53	
掛数	1	1	1	1	

HD性能 14.4mブーム+4.4m+47mヘビーリフトジブ

オフセット	10°	20°	30°	45°	60°
作業半径 (m)	荷重 (ton)	荷重 (ton)	荷重 (ton)	荷重 (ton)	荷重 (ton)
16.0	12.0				
18.0	12.0				
20.0	12.0				
22.0	12.0				
24.0	12.0	12.0			
26.0	12.0	12.0			
28.0	12.0	12.0			
30.0	12.0	12.0			
32.0	12.0	12.0	12.0		
34.0	12.0	12.0	12.0		
36.0	12.0	12.0	11.8		
38.0	12.0	12.0	11.1		
40.0	12.0	11.4	10.4	9.1	
42.0	11.8	10.7	9.8	8.7	
44.0	11.0	10.1	9.3	8.3	
46.0	10.3	9.5	8.8	7.9	7.2
48.0	9.7	9.0	8.4	7.6	7.0
50.0	9.1	8.5	8.0	7.3	6.8
55.0	8.0	7.6	7.2	6.7	
60.0	7.0	6.8	6.6		
危険角度 (°)	10	20	30	45	60
フック種類	12t	12t	12t	12t	12t
フック質量 (t)	0.53	0.53	0.53	0.53	0.53
掛数	1	1	1	1	1

HD性能 19.55mブーム+4.4m+47mヘビーリフトジブ

オフセット	10°	20°	30°	45°	60°
作業半径 (m)	荷重 (ton)	荷重 (ton)	荷重 (ton)	荷重 (ton)	荷重 (ton)
18.0	12.0				
20.0	12.0				
22.0	12.0				
24.0	12.0	12.0			
26.0	12.0	12.0			
28.0	12.0	12.0			
30.0	12.0	12.0			
32.0	12.0	12.0	12.0		
34.0	12.0	12.0	12.0		
36.0	12.0	12.0	12.0		
38.0	12.0	12.0	11.5		
40.0	12.0	12.0	10.9	9.3	
42.0	12.0	11.5	10.3	8.9	
44.0	12.0	10.8	9.8	8.5	
46.0	11.4	10.2	9.3	8.1	7.3
48.0	10.7	9.7	8.9	7.8	7.1
50.0	10.1	9.2	8.5	7.5	6.9
55.0	8.5	8.2	7.6	7.0	6.6
60.0	6.8	7.3	7.0	6.6	
65.0	5.4	5.7	5.9		
危険角度 (°)	10	20	30	45	60
フック種類	12t	12t	12t	12t	12t
フック質量 (t)	0.53	0.53	0.53	0.53	0.53
掛数	1	1	1	1	1

HD性能 23.6mブーム+4.4m+47mヘビーリフトジブ

オフセット	10°	20°	30°	45°	60°
作業半径 (m)	荷重 (ton)	荷重 (ton)	荷重 (ton)	荷重 (ton)	荷重 (ton)
18.0	12.0				
20.0	12.0				
22.0	12.0				
24.0	12.0				
26.0	12.0	12.0			
28.0	12.0	12.0			
30.0	12.0	12.0			
32.0	12.0	12.0	12.0		
34.0	12.0	12.0	12.0		
36.0	12.0	12.0	12.0		
38.0	12.0	12.0	11.8		
40.0	12.0	12.0	11.2	9.4	
42.0	12.0	12.0	10.6	9.0	
44.0	12.0	11.4	10.1	8.6	
46.0	11.3	10.8	9.6	8.3	7.3
48.0	10.3	10.2	9.2	8.0	7.1
50.0	9.3	9.7	8.8	7.7	7.0
55.0	7.3	8.2	8.0	7.1	6.6
60.0	5.7	6.3	7.0	6.7	
65.0	4.2	4.7	5.2	5.5	
70.0	2.9	3.2			
危険角度 (°)	10	20	30	45	60
フック種類	12t	12t	12t	12t	12t
フック質量 (t)	0.53	0.53	0.53	0.53	0.53
掛数	1	1	1	1	1

HD性能 32mブーム+4.4m+47mヘビーリフトジブ

オフセット	10°	20°	30°	45°	60°
作業半径 (m)	荷重 (ton)	荷重 (ton)	荷重 (ton)	荷重 (ton)	荷重 (ton)
20.0	12.0				
22.0	12.0				
24.0	12.0				
26.0	12.0	12.0			
28.0	12.0	12.0			
30.0	12.0	12.0			
32.0	12.0	12.0			
34.0	12.0	12.0	12.0		
36.0	12.0	12.0	12.0		
38.0	12.0	12.0	12.0		
40.0	12.0	12.0	11.8		
42.0	12.0	12.0	11.3	9.2	
44.0	11.5	12.0	10.8	8.9	
46.0	10.4	11.8	10.3	8.6	
48.0	9.4	10.7	9.8	8.3	7.2
50.0	8.5	9.7	9.4	8.0	7.1
55.0	6.5	7.5	8.6	7.5	6.7
60.0	4.8	5.7	6.5	7.0	6.5
65.0	3.3	4.1	4.7	5.5	
70.0	2.1	2.7	3.1	3.6	
75.0			1.6		
危険角度 (°)	30	34	34	45	60
フック種類	12t	12t	12t	12t	12t
フック質量 (t)	0.53	0.53	0.53	0.53	0.53
掛数	1	1	1	1	1

HD性能 40mブーム+4.4m+47mヘビーリフトジブ

オフセット	10°	20°	30°	45°	60°
作業半径 (m)	荷重 (ton)	荷重 (ton)	荷重 (ton)	荷重 (ton)	荷重 (ton)
20.0	8.0				
22.0	8.0				
24.0	8.0				
26.0	8.0				
28.0	8.0	8.0			
30.0	8.0	8.0			
32.0	8.0	8.0			
34.0	8.0	8.0	8.0		
36.0	8.0	8.0	8.0		
38.0	8.0	8.0	8.0		
40.0	8.0	8.0	8.0		
42.0	8.0	8.0	8.0		
44.0	8.0	8.0	8.0	8.0	
46.0	8.0	8.0	8.0	8.0	
48.0	8.0	8.0	8.0	8.0	
50.0	7.8	8.0	8.0	8.0	6.3
55.0	5.8	7.0	8.0	7.7	6.2
60.0	4.1	5.1	6.1	7.3	6.1
65.0	2.6	3.5	4.3	5.4	5.9
70.0		2.1	2.8	3.5	
75.0				1.9	
危険角度 (°)	45	45	47	47	60
フック種類	12t	12t	12t	12t	12t
フック質量 (t)	0.53	0.53	0.53	0.53	0.53
掛数	1	1	1	1	1

HD性能 45mブーム+4.4m+47mヘビーリフトジブ

オフセット	10°	20°	30°	45°	60°
作業半径 (m)	荷重 (ton)	荷重 (ton)	荷重 (ton)	荷重 (ton)	荷重 (ton)
20.0	7.5				
22.0	7.5				
24.0	7.5				
26.0	7.5				
28.0	7.5	7.5			
30.0	7.5	7.5			
32.0	7.5	7.5			
34.0	7.5	7.5			
36.0	7.5	7.5	7.5		
38.0	7.5	7.5	7.5		
40.0	7.5	7.5	7.5		
42.0	7.5	7.5	7.5		
44.0	7.5	7.5	7.5	7.1	
46.0	7.5	7.5	7.5	7.0	
48.0	7.5	7.5	7.5	6.8	
50.0	7.5	7.5	7.5	6.7	5.2
55.0	5.4	6.7	7.5	6.5	5.1
60.0	3.7	4.8	5.9	6.4	5.1
65.0	2.2	3.2	4.1	5.2	5.1
70.0			1.8	2.6	3.8
75.0				1.8	
危険角度 (°)	48	49	51	51	60
フック種類	12t	12t	12t	12t	12t
フック質量 (t)	0.53	0.53	0.53	0.53	0.53
掛数	1	1	1	1	1

HD性能 50mブーム+4.4m+47mヘビーリフトジブ

オフセット	10°	20°	30°	45°	60°
作業半径 (m)	荷重 (ton)	荷重 (ton)	荷重 (ton)	荷重 (ton)	荷重 (ton)
22.0	5.0				
24.0	5.0				
26.0	5.0				
28.0	5.0				
30.0	5.0	5.0			
32.0	5.0	5.0			
34.0	5.0	5.0			
36.0	5.0	5.0	5.0		
38.0	5.0	5.0	4.9		
40.0	5.0	5.0	4.8		
42.0	5.0	5.0	4.6		
44.0	5.0	5.0	4.5	3.4	
46.0	5.0	5.0	4.4	3.3	
48.0	5.0	5.0	4.3	3.3	
50.0	5.0	4.9	4.2	3.2	2.2
55.0	5.0	4.7	4.1	3.1	2.2
60.0	3.3	4.5	3.9	3.1	2.2
65.0	1.9	2.9	3.9	3.0	2.2
70.0			2.4	3.0	2.2
75.0				1.8	
危険角度 (°)	52	55	55	55	60
フック種類	12t	12t	12t	12t	12t
フック質量 (t)	0.53	0.53	0.53	0.53	0.53
掛数	1	1	1	1	1

HD性能 53.9mブーム+4.4m+47mヘビーリフトジブ

オフセット	10°	20°	30°	45°	60°
作業半径 (m)	荷重 (ton)	荷重 (ton)	荷重 (ton)	荷重 (ton)	荷重 (ton)
22.0	4.0				
24.0	4.0				
26.0	4.0				
28.0	4.0				
30.0	4.0	4.0			
32.0	4.0	4.0			
34.0	4.0	4.0			
36.0	4.0	4.0	3.3		
38.0	4.0	3.9	3.2		
40.0	4.0	3.8	3.1		
42.0	4.0	3.6	3.0		
44.0	4.0	3.5	2.9		
46.0	4.0	3.4	2.8	2.0	
48.0	4.0	3.4	2.8	1.9	
50.0	3.9	3.3	2.7	1.9	
55.0	3.6	3.1	2.6	1.8	
60.0	3.1	3.0	2.5	1.8	
65.0	1.6	2.7	2.4	1.8	
70.0			2.2	1.8	
75.0				1.7	
危険角度 (°)	54	56	56	57	
フック種類	12t	12t	12t	12t	
フック質量 (t)	0.53	0.53	0.53	0.53	
掛数	1	1	1	1	

HE性能 14.4mブーム+4.4m+47mヘビーリフトジブ

オフセット	10°	20°	30°	45°	60°
作業半径 (m)	荷重 (ton)	荷重 (ton)	荷重 (ton)	荷重 (ton)	荷重 (ton)
16.0	12.0				
18.0	12.0				
20.0	12.0				
22.0	12.0				
24.0	12.0	12.0			
26.0	12.0	12.0			
28.0	12.0	12.0			
30.0	12.0	12.0			
32.0	12.0	12.0	12.0		
34.0	12.0	12.0	12.0		
36.0	12.0	12.0	11.8		
38.0	12.0	12.0	11.1		
40.0	12.0	11.4	10.4	9.1	
42.0	11.8	10.7	9.8	8.7	
44.0	11.0	10.1	9.3	8.3	
46.0	10.3	9.5	8.8	7.9	7.2
48.0	9.7	9.0	8.4	7.6	7.0
50.0	9.1	8.5	8.0	7.3	6.8
55.0	8.0	7.6	7.2	6.7	
60.0	6.9	6.8	6.6		
危険角度 (°)	10	20	30	45	60
フック種類	12t	12t	12t	12t	12t
フック質量 (t)	0.53	0.53	0.53	0.53	0.53
掛数	1	1	1	1	1

HE性能 19.55mブーム+4.4m+47mヘビーリフトジブ

オフセット	10°	20°	30°	45°	60°
作業半径 (m)	荷重 (ton)	荷重 (ton)	荷重 (ton)	荷重 (ton)	荷重 (ton)
18.0	12.0				
20.0	12.0				
22.0	12.0				
24.0	12.0	12.0			
26.0	12.0	12.0			
28.0	12.0	12.0			
30.0	12.0	12.0			
32.0	12.0	12.0	12.0		
34.0	12.0	12.0	12.0		
36.0	12.0	12.0	12.0		
38.0	12.0	12.0	11.5		
40.0	12.0	12.0	10.9	9.3	
42.0	12.0	11.5	10.3	8.9	
44.0	11.4	10.8	9.8	8.5	
46.0	10.4	10.2	9.3	8.1	7.3
48.0	9.5	9.7	8.9	7.8	7.1
50.0	8.6	9.2	8.5	7.5	6.9
55.0	6.8	7.5	7.6	7.0	6.6
60.0	5.3	5.8	6.3	6.6	
65.0	3.9	4.3	4.5		
危険角度 (°)	10	20	30	45	60
フック種類	12t	12t	12t	12t	12t
フック質量 (t)	0.53	0.53	0.53	0.53	0.53
掛数	1	1	1	1	1

HE性能 23.6mブーム+4.4m+47mヘビーリフトジブ

オフセット	10°	20°	30°	45°	60°
作業半径 (m)	荷重 (ton)	荷重 (ton)	荷重 (ton)	荷重 (ton)	荷重 (ton)
18.0	12.0				
20.0	12.0				
22.0	12.0				
24.0	12.0				
26.0	12.0	12.0			
28.0	12.0	12.0			
30.0	12.0	12.0			
32.0	12.0	12.0	12.0		
34.0	12.0	12.0	12.0		
36.0	12.0	12.0	12.0		
38.0	12.0	12.0	11.8		
40.0	12.0	12.0	11.2	9.4	
42.0	11.4	12.0	10.6	9.0	
44.0	10.3	11.4	10.1	8.6	
46.0	9.3	10.5	9.6	8.3	7.3
48.0	8.4	9.5	9.2	8.0	7.1
50.0	7.5	8.6	8.8	7.7	7.0
55.0	5.7	6.5	7.4	7.1	6.6
60.0	4.1	4.8	5.5	6.3	
65.0	2.8	3.3	3.7	4.1	
70.0	1.6	1.9			
危険角度 (°)	10	20	30	45	60
フック種類	12t	12t	12t	12t	12t
フック質量 (t)	0.53	0.53	0.53	0.53	0.53
掛数	1	1	1	1	1

HE性能 32mブーム+4.4m+47mヘビーリフトジブ

オフセット	10°	20°	30°	45°	60°
作業半径 (m)	荷重 (ton)	荷重 (ton)	荷重 (ton)	荷重 (ton)	荷重 (ton)
20.0	12.0				
22.0	12.0				
24.0	12.0				
26.0	12.0	12.0			
28.0	12.0	12.0			
30.0	12.0	12.0			
32.0	12.0	12.0			
34.0	12.0	12.0	12.0		
36.0	12.0	12.0	12.0		
38.0	12.0	12.0	12.0		
40.0	11.7	12.0	11.8		
42.0	10.5	12.0	11.3	9.2	
44.0	9.4	10.9	10.8	8.9	
46.0	8.4	9.8	10.3	8.6	
48.0	7.5	8.8	9.8	8.3	7.2
50.0	6.6	7.9	9.1	8.0	7.1
55.0	4.8	5.9	6.9	7.5	6.7
60.0	3.3	4.1	5.0	6.1	6.5
65.0	1.9	2.7	3.3	4.1	
70.0			1.8	2.3	
危険角度 (°)	38	42	43	45	60
フック種類	12t	12t	12t	12t	12t
フック質量 (t)	0.53	0.53	0.53	0.53	0.53
掛数	1	1	1	1	1

HE性能 40mブーム+4.4m+47mヘビーリフトジブ

オフセット	10°	20°	30°	45°	60°
作業半径 (m)	荷重 (ton)	荷重 (ton)	荷重 (ton)	荷重 (ton)	荷重 (ton)
20.0	8.0				
22.0	8.0				
24.0	8.0				
26.0	8.0				
28.0	8.0	8.0			
30.0	8.0	8.0			
32.0	8.0	8.0			
34.0	8.0	8.0	8.0		
36.0	8.0	8.0	8.0		
38.0	8.0	8.0	8.0		
40.0	8.0	8.0	8.0		
42.0	8.0	8.0	8.0		
44.0	8.0	8.0	8.0	8.0	
46.0	7.7	8.0	8.0	8.0	
48.0	6.8	8.0	8.0	8.0	
50.0	5.9	7.4	8.0	8.0	6.3
55.0	4.1	5.3	6.5	7.7	6.2
60.0	2.5	3.6	4.6	5.9	6.1
65.0		2.1	2.9	4.0	4.5
70.0				2.2	
危険角度 (°)	50	51	53	53	60
フック種類	12t	12t	12t	12t	12t
フック質量 (t)	0.53	0.53	0.53	0.53	0.53
掛数	1	1	1	1	1

HE性能 45mブーム+4.4m+47mヘビーリフトジブ

オフセット	10°	20°	30°	45°	60°
作業半径 (m)	荷重 (ton)	荷重 (ton)	荷重 (ton)	荷重 (ton)	荷重 (ton)
20.0	7.5				
22.0	7.5				
24.0	7.5				
26.0	7.5				
28.0	7.5	7.5			
30.0	7.5	7.5			
32.0	7.5	7.5			
34.0	7.5	7.5			
36.0	7.5	7.5	7.5		
38.0	7.5	7.5	7.5		
40.0	7.5	7.5	7.5		
42.0	7.5	7.5	7.5		
44.0	7.5	7.5	7.5	7.1	
46.0	7.3	7.5	7.5	7.0	
48.0	6.4	7.5	7.5	6.8	
50.0	5.6	7.1	7.5	6.7	5.2
55.0	3.7	5.0	6.2	6.5	5.1
60.0	2.2	3.3	4.3	5.7	5.1
65.0		1.8	2.7	3.8	4.5
70.0				2.2	2.5
危険角度 (°)	53	54	56	56	60
フック種類	12t	12t	12t	12t	12t
フック質量 (t)	0.53	0.53	0.53	0.53	0.53
掛数	1	1	1	1	1

HE性能 50mブーム+4.4m+47mヘビーリフトジブ

オフセット	10°	20°	30°	45°	60°
作業半径 (m)	荷重 (ton)	荷重 (ton)	荷重 (ton)	荷重 (ton)	荷重 (ton)
22.0	5.0				
24.0	5.0				
26.0	5.0				
28.0	5.0				
30.0	5.0	5.0			
32.0	5.0	5.0			
34.0	5.0	5.0			
36.0	5.0	5.0	5.0		
38.0	5.0	5.0	4.9		
40.0	5.0	5.0	4.8		
42.0	5.0	5.0	4.6		
44.0	5.0	5.0	4.5	3.4	
46.0	5.0	5.0	4.4	3.3	
48.0	5.0	5.0	4.3	3.3	
50.0	5.0	4.9	4.2	3.2	2.2
55.0	3.3	4.7	4.1	3.1	2.2
60.0	1.8	3.0	3.9	3.1	2.2
65.0			2.5	3.0	2.2
70.0				2.0	2.2
危険角度 (°)	56	59	59	59	60
フック種類	12t	12t	12t	12t	12t
フック質量 (t)	0.53	0.53	0.53	0.53	0.53
掛数	1	1	1	1	1

HE性能 53.9mブーム+4.4m+47mヘビーリフトジブ

オフセット	10°	20°	30°	45°	60°
作業半径 (m)	荷重 (ton)	荷重 (ton)	荷重 (ton)	荷重 (ton)	荷重 (ton)
22.0	4.0				
24.0	4.0				
26.0	4.0				
28.0	4.0				
30.0	4.0	4.0			
32.0	4.0	4.0			
34.0	4.0	4.0			
36.0	4.0	4.0	3.3		
38.0	4.0	3.9	3.2		
40.0	4.0	3.8	3.1		
42.0	4.0	3.6	3.0		
44.0	4.0	3.5	2.9		
46.0	4.0	3.4	2.8	2.0	
48.0	4.0	3.4	2.8	1.9	
50.0	3.9	3.3	2.7	1.9	
55.0	3.1	3.1	2.6	1.8	
60.0		2.8	2.5	1.8	
65.0			2.3	1.8	
70.0				1.8	
危険角度 (°)	60	60	60	61	
フック種類	12t	12t	12t	12t	
フック質量 (t)	0.53	0.53	0.53	0.53	
掛数	1	1	1	1	

HF性能 14.4mブーム+4.4m+47mヘビーリフトジブ

オフセット	10°	20°	30°	45°	60°
作業半径 (m)	荷重 (ton)	荷重 (ton)	荷重 (ton)	荷重 (ton)	荷重 (ton)
16.0	12.0				
18.0	12.0				
20.0	12.0				
22.0	12.0				
24.0	12.0	12.0			
26.0	12.0	12.0			
28.0	12.0	12.0			
30.0	12.0	12.0			
32.0	12.0	12.0	12.0		
34.0	12.0	12.0	12.0		
36.0	12.0	12.0	11.8		
38.0	12.0	12.0	11.1		
40.0	12.0	11.4	10.4	9.1	
42.0	11.8	10.7	9.8	8.7	
44.0	11.0	10.1	9.3	8.3	
46.0	10.3	9.5	8.8	7.9	7.2
48.0	9.7	9.0	8.4	7.6	7.0
50.0	9.0	8.5	8.0	7.3	6.8
55.0	7.4	7.6	7.2	6.7	
60.0	6.0	6.3	6.5		
危険角度 (°)	10	20	30	45	60
フック種類	12t	12t	12t	12t	12t
フック質量 (t)	0.53	0.53	0.53	0.53	0.53
掛数	1	1	1	1	1

HF性能 19.55mブーム+4.4m+47mヘビーリフトジブ

オフセット	10°	20°	30°	45°	60°
作業半径 (m)	荷重 (ton)	荷重 (ton)	荷重 (ton)	荷重 (ton)	荷重 (ton)
18.0	12.0				
20.0	12.0				
22.0	12.0				
24.0	12.0	12.0			
26.0	12.0	12.0			
28.0	12.0	12.0			
30.0	12.0	12.0			
32.0	12.0	12.0	12.0		
34.0	12.0	12.0	12.0		
36.0	12.0	12.0	12.0		
38.0	12.0	12.0	11.5		
40.0	12.0	12.0	10.9	9.3	
42.0	11.0	11.5	10.3	8.9	
44.0	10.1	10.8	9.8	8.5	
46.0	9.2	10.0	9.3	8.1	7.3
48.0	8.3	9.2	8.9	7.8	7.1
50.0	7.5	8.4	8.5	7.5	6.9
55.0	5.8	6.5	7.2	7.0	6.6
60.0	4.3	4.9	5.4	5.9	
65.0	3.1	3.4	3.6		
危険角度 (°)	10	20	30	45	60
フック種類	12t	12t	12t	12t	12t
フック質量 (t)	0.53	0.53	0.53	0.53	0.53
掛数	1	1	1	1	1

HF性能 23.6mブーム+4.4m+47mヘビーリフトジブ

オフセット	10°	20°	30°	45°	60°
作業半径 (m)	荷重 (ton)	荷重 (ton)	荷重 (ton)	荷重 (ton)	荷重 (ton)
18.0	12.0				
20.0	12.0				
22.0	12.0				
24.0	12.0				
26.0	12.0	12.0			
28.0	12.0	12.0			
30.0	12.0	12.0			
32.0	12.0	12.0	12.0		
34.0	12.0	12.0	12.0		
36.0	12.0	12.0	12.0		
38.0	12.0	12.0	11.8		
40.0	11.2	12.0	11.2	9.4	
42.0	10.0	11.3	10.6	9.0	
44.0	9.0	10.3	10.1	8.6	
46.0	8.1	9.3	9.6	8.3	7.3
48.0	7.2	8.4	9.2	8.0	7.1
50.0	6.4	7.5	8.5	7.7	7.0
55.0	4.7	5.5	6.4	7.1	6.6
60.0	3.2	3.9	4.6	5.4	
65.0	1.9	2.4	2.9	3.3	
危険角度 (°)	25	28	30	45	60
フック種類	12t	12t	12t	12t	12t
フック質量 (t)	0.53	0.53	0.53	0.53	0.53
掛数	1	1	1	1	1

HF性能 32mブーム+4.4m+47mヘビーリフトジブ

オフセット	10°	20°	30°	45°	60°
作業半径 (m)	荷重 (ton)	荷重 (ton)	荷重 (ton)	荷重 (ton)	荷重 (ton)
20.0	12.0				
22.0	12.0				
24.0	12.0				
26.0	12.0	12.0			
28.0	12.0	12.0			
30.0	12.0	12.0			
32.0	12.0	12.0			
34.0	12.0	12.0	12.0		
36.0	12.0	12.0	12.0		
38.0	11.6	12.0	12.0		
40.0	10.3	12.0	11.8		
42.0	9.2	10.8	11.3	9.2	
44.0	8.1	9.7	10.8	8.9	
46.0	7.2	8.6	9.9	8.6	
48.0	6.3	7.7	9.0	8.3	7.2
50.0	5.5	6.8	8.0	8.0	7.1
55.0	3.8	4.9	5.9	7.3	6.7
60.0	2.3	3.2	4.1	5.2	5.9
65.0		1.8	2.5	3.3	
危険角度 (°)	44	44	46	49	60
フック種類	12t	12t	12t	12t	12t
フック質量 (t)	0.53	0.53	0.53	0.53	0.53
掛数	1	1	1	1	1

HF性能 40mブーム+4.4m+47mヘビーリフトジブ

オフセット	10°	20°	30°	45°	60°
作業半径 (m)	荷重 (ton)	荷重 (ton)	荷重 (ton)	荷重 (ton)	荷重 (ton)
20.0	8.0				
22.0	8.0				
24.0	8.0				
26.0	8.0				
28.0	8.0	8.0			
30.0	8.0	8.0			
32.0	8.0	8.0			
34.0	8.0	8.0	8.0		
36.0	8.0	8.0	8.0		
38.0	8.0	8.0	8.0		
40.0	8.0	8.0	8.0		
42.0	8.0	8.0	8.0		
44.0	7.4	8.0	8.0	8.0	
46.0	6.5	8.0	8.0	8.0	
48.0	5.6	7.1	8.0	8.0	
50.0	4.8	6.2	7.6	8.0	6.3
55.0	3.1	4.3	5.5	7.0	6.2
60.0	1.6	2.7	3.6	4.9	5.8
65.0			2.1	3.1	3.7
危険角度 (°)	50	54	54	57	60
フック種類	12t	12t	12t	12t	12t
フック質量 (t)	0.53	0.53	0.53	0.53	0.53
掛数	1	1	1	1	1

HF性能 45mブーム+4.4m+47mヘビーリフトジブ

オフセット	10°	20°	30°	45°	60°
作業半径 (m)	荷重 (ton)	荷重 (ton)	荷重 (ton)	荷重 (ton)	荷重 (ton)
20.0	7.5				
22.0	7.5				
24.0	7.5				
26.0	7.5				
28.0	7.5	7.5			
30.0	7.5	7.5			
32.0	7.5	7.5			
34.0	7.5	7.5			
36.0	7.5	7.5	7.5		
38.0	7.5	7.5	7.5		
40.0	7.5	7.5	7.5		
42.0	7.5	7.5	7.5		
44.0	7.1	7.5	7.5	7.1	
46.0	6.1	7.5	7.5	7.0	
48.0	5.2	6.8	7.5	6.8	
50.0	4.4	5.9	7.4	6.7	5.2
55.0	2.7	4.0	5.2	6.5	5.1
60.0		2.3	3.4	4.8	5.1
65.0			1.9	3.0	3.7
70.0					1.7
危険角度 (°)	57	57	57	60	60
フック種類	12t	12t	12t	12t	12t
フック質量 (t)	0.53	0.53	0.53	0.53	0.53
掛数	1	1	1	1	1

HF性能 50mブーム+4.4m+47mヘビーリフトジブ

オフセット	10°	20°	30°	45°	60°
作業半径 (m)	荷重 (ton)	荷重 (ton)	荷重 (ton)	荷重 (ton)	荷重 (ton)
22.0	5.0				
24.0	5.0				
26.0	5.0				
28.0	5.0				
30.0	5.0	5.0			
32.0	5.0	5.0			
34.0	5.0	5.0			
36.0	5.0	5.0	5.0		
38.0	5.0	5.0	4.9		
40.0	5.0	5.0	4.8		
42.0	5.0	5.0	4.6		
44.0	5.0	5.0	4.5	3.4	
46.0	5.0	5.0	4.4	3.3	
48.0	4.9	5.0	4.3	3.3	
50.0	4.1	4.9	4.2	3.2	2.2
55.0	2.3	3.7	4.1	3.1	2.2
60.0		2.1	3.2	3.1	2.2
65.0			1.6	2.9	2.2
70.0					1.8
危険角度 (°)	59	60	60	62	62
フック種類	12t	12t	12t	12t	12t
フック質量 (t)	0.53	0.53	0.53	0.53	0.53
掛数	1	1	1	1	1

HF性能 53.9mブーム+4.4m+47mヘビーリフトジブ

オフセット	10°	20°	30°	45°	60°
作業半径 (m)	荷重 (ton)	荷重 (ton)	荷重 (ton)	荷重 (ton)	荷重 (ton)
22.0	4.0				
24.0	4.0				
26.0	4.0				
28.0	4.0				
30.0	4.0	4.0			
32.0	4.0	4.0			
34.0	4.0	4.0			
36.0	4.0	4.0	3.3		
38.0	4.0	3.9	3.2		
40.0	4.0	3.8	3.1		
42.0	4.0	3.6	3.0		
44.0	4.0	3.5	2.9		
46.0	4.0	3.4	2.8	2.0	
48.0	4.0	3.4	2.8	1.9	
50.0	3.8	3.3	2.7	1.9	
55.0		3.1	2.6	1.8	
60.0		1.8	2.5	1.8	
65.0				1.8	
危険角度 (°)	62	62	64	64	
フック種類	12t	12t	12t	12t	
フック質量 (t)	0.53	0.53	0.53	0.53	
掛数	1	1	1	1	

HG性能 14.4mブーム+4.4m+47mヘビーリフトジブ

オフセット	10°	20°	30°	45°	60°
作業半径 (m)	荷重 (ton)	荷重 (ton)	荷重 (ton)	荷重 (ton)	荷重 (ton)
16.0	12.0				
18.0	12.0				
20.0	12.0				
22.0	12.0				
24.0	12.0	12.0			
26.0	12.0	12.0			
28.0	12.0	12.0			
30.0	12.0	12.0			
32.0	12.0	12.0	12.0		
34.0	12.0	12.0	12.0		
36.0	12.0	12.0	11.8		
38.0	12.0	12.0	11.1		
40.0	11.4	11.4	10.4	9.1	
42.0	10.5	10.7	9.8	8.7	
44.0	9.6	10.1	9.3	8.3	
46.0	8.9	9.4	8.8	7.9	7.2
48.0	8.2	8.7	8.4	7.6	7.0
50.0	7.5	8.0	8.0	7.3	6.8
55.0	6.1	6.5	6.8	6.7	
60.0	5.0	5.2	5.4		
危険角度 (°)	10	20	30	45	60
フック種類	12t	12t	12t	12t	12t
フック質量 (t)	0.53	0.53	0.53	0.53	0.53
掛数	1	1	1	1	1

HG性能 19.55mブーム+4.4m+47mヘビーリフトジブ

オフセット	10°	20°	30°	45°	60°
作業半径 (m)	荷重 (ton)	荷重 (ton)	荷重 (ton)	荷重 (ton)	荷重 (ton)
18.0	12.0				
20.0	12.0				
22.0	12.0				
24.0	12.0	12.0			
26.0	12.0	12.0			
28.0	12.0	12.0			
30.0	12.0	12.0			
32.0	12.0	12.0	12.0		
34.0	12.0	12.0	12.0		
36.0	12.0	12.0	12.0		
38.0	11.3	12.0	11.5		
40.0	10.2	11.2	10.9	9.3	
42.0	9.3	10.2	10.3	8.9	
44.0	8.4	9.3	9.8	8.5	
46.0	7.7	8.4	9.2	8.1	7.3
48.0	7.0	7.7	8.4	7.8	7.1
50.0	6.3	7.0	7.6	7.5	6.9
55.0	4.8	5.5	6.0	6.7	6.6
60.0	3.4	3.9	4.4	5.0	
65.0	2.2	2.5	2.8		
危険角度 (°)	10	20	30	45	60
フック種類	12t	12t	12t	12t	12t
フック質量 (t)	0.53	0.53	0.53	0.53	0.53
掛数	1	1	1	1	1

HG性能 23.6mブーム+4.4m+47mヘビーリフトジブ

オフセット	10°	20°	30°	45°	60°
作業半径 (m)	荷重 (ton)	荷重 (ton)	荷重 (ton)	荷重 (ton)	荷重 (ton)
18.0	12.0				
20.0	12.0				
22.0	12.0				
24.0	12.0				
26.0	12.0	12.0			
28.0	12.0	12.0			
30.0	12.0	12.0			
32.0	12.0	12.0	12.0		
34.0	12.0	12.0	12.0		
36.0	11.7	12.0	12.0		
38.0	10.5	11.7	11.8		
40.0	9.4	10.6	11.2	9.4	
42.0	8.5	9.5	10.6	9.0	
44.0	7.6	8.6	9.6	8.6	
46.0	6.9	7.8	8.7	8.3	7.3
48.0	6.0	7.0	7.8	8.0	7.1
50.0	5.3	6.3	7.1	7.7	7.0
55.0	3.7	4.5	5.4	6.2	6.6
60.0	2.3	3.0	3.6	4.5	
65.0		1.6	2.0	2.4	
危険角度 (°)	35	35	37	45	60
フック種類	12t	12t	12t	12t	12t
フック質量 (t)	0.53	0.53	0.53	0.53	0.53
掛数	1	1	1	1	1

HG性能 32mブーム+4.4m+47mヘビーリフトジブ

オフセット	10°	20°	30°	45°	60°
作業半径 (m)	荷重 (ton)	荷重 (ton)	荷重 (ton)	荷重 (ton)	荷重 (ton)
20.0	12.0				
22.0	12.0				
24.0	12.0				
26.0	12.0	12.0			
28.0	12.0	12.0			
30.0	12.0	12.0			
32.0	12.0	12.0			
34.0	12.0	12.0	12.0		
36.0	11.1	12.0	12.0		
38.0	9.9	11.3	12.0		
40.0	8.8	10.1	11.4		
42.0	7.8	9.1	10.3	9.2	
44.0	6.9	8.1	9.2	8.9	
46.0	6.0	7.3	8.3	8.6	
48.0	5.2	6.5	7.5	8.3	7.2
50.0	4.4	5.7	6.7	8.0	7.1
55.0	2.8	3.8	4.9	6.0	6.7
60.0		2.3	3.1	4.2	4.9
65.0			1.6	2.4	
危険角度 (°)	49	49	49	51	60
フック種類	12t	12t	12t	12t	12t
フック質量 (t)	0.53	0.53	0.53	0.53	0.53
掛数	1	1	1	1	1

HG性能 40mブーム+4.4m+47mヘビーリフトジブ

オフセット	10°	20°	30°	45°	60°
作業半径 (m)	荷重 (ton)	荷重 (ton)	荷重 (ton)	荷重 (ton)	荷重 (ton)
20.0	8.0				
22.0	8.0				
24.0	8.0				
26.0	8.0				
28.0	8.0	8.0			
30.0	8.0	8.0			
32.0	8.0	8.0			
34.0	8.0	8.0	8.0		
36.0	8.0	8.0	8.0		
38.0	8.0	8.0	8.0		
40.0	8.0	8.0	8.0		
42.0	7.2	8.0	8.0		
44.0	6.2	7.7	8.0	8.0	
46.0	5.3	6.9	8.0	8.0	
48.0	4.5	6.0	7.2	8.0	
50.0	3.7	5.1	6.4	7.8	6.3
55.0	2.1	3.3	4.5	5.9	6.2
60.0		1.7	2.7	4.0	4.9
65.0				2.2	2.8
危険角度 (°)	55	56	58	58	60
フック種類	12t	12t	12t	12t	12t
フック質量 (t)	0.53	0.53	0.53	0.53	0.53
掛数	1	1	1	1	1

HG性能 45mブーム+4.4m+47mヘビーリフトジブ

オフセット	10°	20°	30°	45°	60°
作業半径 (m)	荷重 (ton)	荷重 (ton)	荷重 (ton)	荷重 (ton)	荷重 (ton)
20.0	7.5				
22.0	7.5				
24.0	7.5				
26.0	7.5				
28.0	7.5	7.5			
30.0	7.5	7.5			
32.0	7.5	7.5			
34.0	7.5	7.5			
36.0	7.5	7.5	7.5		
38.0	7.5	7.5	7.5		
40.0	7.5	7.5	7.5		
42.0	6.8	7.5	7.5		
44.0	5.8	7.5	7.5	7.1	
46.0	4.9	6.6	7.5	7.0	
48.0	4.1	5.7	7.0	6.8	
50.0	3.3	4.8	6.2	6.5	5.2
55.0		3.0	4.2	5.8	5.1
60.0			2.5	3.9	4.9
65.0				2.1	2.8
危険角度 (°)	60	61	62	62	62
フック種類	12t	12t	12t	12t	12t
フック質量 (t)	0.53	0.53	0.53	0.53	0.53
掛数	1	1	1	1	1

HG性能 50mブーム+4.4m+47mヘビーリフトジブ

オフセット	10°	20°	30°	45°	60°
作業半径 (m)	荷重 (ton)	荷重 (ton)	荷重 (ton)	荷重 (ton)	荷重 (ton)
22.0	5.0				
24.0	5.0				
26.0	5.0				
28.0	5.0				
30.0	5.0	5.0			
32.0	5.0	5.0			
34.0	5.0	5.0			
36.0	5.0	5.0	5.0		
38.0	5.0	5.0	4.9		
40.0	5.0	5.0	4.8		
42.0	5.0	5.0	4.6		
44.0	5.0	5.0	4.5	3.4	
46.0	4.5	5.0	4.4	3.3	
48.0	3.7	5.0	4.3	3.3	
50.0	3.0	4.5	4.2	3.2	2.2
55.0		2.7	4.0	3.1	2.2
60.0			2.3	3.1	2.2
65.0				2.0	2.2
危険角度 (°)	64	65	65	66	66
フック種類	12t	12t	12t	12t	12t
フック質量 (t)	0.53	0.53	0.53	0.53	0.53
掛数	1	1	1	1	1

HG性能 53.9mブーム+4.4m+47mヘビーリフトジブ

オフセット	10°	20°	30°	45°	60°
作業半径 (m)	荷重 (ton)	荷重 (ton)	荷重 (ton)	荷重 (ton)	荷重 (ton)
22.0	4.0				
24.0	4.0				
26.0	4.0				
28.0	4.0				
30.0	4.0	4.0			
32.0	4.0	4.0			
34.0	4.0	4.0			
36.0	4.0	4.0	3.3		
38.0	4.0	3.9	3.2		
40.0	4.0	3.8	3.1		
42.0	4.0	3.6	3.0		
44.0	4.0	3.5	2.9		
46.0	4.0	3.4	2.8	2.0	
48.0	3.5	3.4	2.8	1.9	
50.0		3.3	2.7	1.9	
55.0			2.6	1.8	
60.0				1.8	
危険角度 (°)	66	67	68	68	
フック種類	12t	12t	12t	12t	
フック質量 (t)	0.53	0.53	0.53	0.53	
掛数	1	1	1	1	

HA性能 14.4mブーム+4.4m+54mヘビーリフトジブ

オフセット	10°	20°	30°	45°	60°
作業半径 (m)	荷重 (ton)	荷重 (ton)	荷重 (ton)	荷重 (ton)	荷重 (ton)
18.0	9.3				
20.0	9.3				
22.0	9.2				
24.0	9.2				
26.0	9.2				
28.0	9.2	8.9			
30.0	9.0	8.8			
32.0	8.8	8.7			
34.0	8.8	8.6			
36.0	8.8	8.5	7.9		
38.0	8.7	8.1	7.6		
40.0	8.3	7.8	7.3		
42.0	7.9	7.5	7.0		
44.0	7.6	7.2	6.8		
46.0	7.3	6.9	6.6	6.1	
48.0	7.0	6.7	6.4	5.9	
50.0	6.8	6.5	6.2	5.8	
55.0	6.2	6.0	5.7	5.5	5.0
60.0	5.7	5.6	5.4	5.0	4.7
65.0	5.3	5.1	4.9	4.7	
70.0	4.8				
危険角度 (°)	10	20	30	45	60
フック種類	12t	12t	12t	12t	12t
フック質量 (t)	0.53	0.53	0.53	0.53	0.53
掛数	1	1	1	1	1

HA性能 19.55mブーム+4.4m+54mヘビーリフトジブ

オフセット	10°	20°	30°	45°	60°
作業半径 (m)	荷重 (ton)	荷重 (ton)	荷重 (ton)	荷重 (ton)	荷重 (ton)
20.0	9.3				
22.0	9.2				
24.0	9.2				
26.0	9.2				
28.0	9.0	8.9			
30.0	9.0	8.9			
32.0	8.9	8.9			
34.0	8.9	8.8			
36.0	8.9	8.7	8.0		
38.0	8.8	8.4	7.7		
40.0	8.7	8.0	7.5		
42.0	8.3	7.7	7.2		
44.0	8.0	7.5	7.0		
46.0	7.7	7.2	6.7	6.2	
48.0	7.4	7.0	6.5	6.0	
50.0	7.2	6.7	6.3	5.8	
55.0	6.6	6.2	5.9	5.5	5.1
60.0	6.1	5.8	5.6	5.2	4.8
65.0	5.7	5.5	5.2	4.8	
70.0	5.2	5.0	4.8		
75.0	4.8				
危険角度 (°)	10	20	30	45	60
フック種類	12t	12t	12t	12t	12t
フック質量 (t)	0.53	0.53	0.53	0.53	0.53
掛数	1	1	1	1	1

HA性能 23.6mブーム+4.4m+54mヘビーリフトジブ

オフセット	10°	20°	30°	45°	60°
作業半径 (m)	荷重 (ton)	荷重 (ton)	荷重 (ton)	荷重 (ton)	荷重 (ton)
20.0	9.3				
22.0	9.3				
24.0	9.2				
26.0	9.2				
28.0	9.2	9.1			
30.0	9.0	8.9			
32.0	8.9	8.8			
34.0	8.9	8.7			
36.0	8.9	8.6	8.1		
38.0	8.8	8.5	7.8		
40.0	8.7	8.2	7.6		
42.0	8.6	7.9	7.3		
44.0	8.3	7.6	7.1		
46.0	8.0	7.4	6.9	6.2	
48.0	7.7	7.1	6.7	6.0	
50.0	7.4	6.9	6.5	5.9	
55.0	6.8	6.4	6.0	5.6	5.1
60.0	6.3	6.0	5.7	5.3	4.8
65.0	5.9	5.6	5.4	4.9	4.7
70.0	5.5	5.3	5.0	4.7	
75.0	4.8	4.9	4.7		
危険角度 (°)	15	20	30	45	60
フック種類	12t	12t	12t	12t	12t
フック質量 (t)	0.53	0.53	0.53	0.53	0.53
掛数	1	1	1	1	1

HA性能 32mブーム+4.4m+54mヘビーリフトジブ

オフセット	10°	20°	30°	45°	60°
作業半径 (m)	荷重 (ton)	荷重 (ton)	荷重 (ton)	荷重 (ton)	荷重 (ton)
22.0	9.0				
24.0	9.0				
26.0	9.0				
28.0	9.0				
30.0	9.0	8.8			
32.0	9.0	8.7			
34.0	8.9	8.7			
36.0	8.8	8.6			
38.0	8.8	8.6	8.0		
40.0	8.7	8.6	7.7		
42.0	8.6	8.3	7.5		
44.0	8.6	8.0	7.3		
46.0	8.6	7.7	7.1		
48.0	8.3	7.5	6.9	6.1	
50.0	8.0	7.3	6.7	6.0	
55.0	7.4	6.8	6.3	5.7	5.2
60.0	6.8	6.3	5.9	5.5	4.9
65.0	6.4	6.0	5.6	5.2	4.7
70.0	5.2	5.7	5.4	4.9	4.6
75.0	3.9	4.5	5.0	4.7	
80.0	2.8	3.2	3.6		
85.0	1.8	2.0			
危険角度 (°)	18	20	30	45	60
フック種類	12t	12t	12t	12t	12t
フック質量 (t)	0.53	0.53	0.53	0.53	0.53
掛数	1	1	1	1	1

HA性能 40mブーム+4.4m+54mヘビーリフトジブ

オフセット	10°	20°	30°	45°	60°
作業半径 (m)	荷重 (ton)	荷重 (ton)	荷重 (ton)	荷重 (ton)	荷重 (ton)
22.0	6.0				
24.0	6.0				
26.0	6.0				
28.0	6.0				
30.0	6.0				
32.0	6.0	6.0			
34.0	6.0	6.0			
36.0	6.0	6.0			
38.0	6.0	6.0	6.0		
40.0	6.0	6.0	6.0		
42.0	6.0	6.0	6.0		
44.0	6.0	6.0	6.0		
46.0	6.0	6.0	6.0		
48.0	6.0	6.0	6.0	6.0	
50.0	6.0	6.0	6.0	6.0	
55.0	6.0	6.0	6.0	5.8	4.9
60.0	6.0	6.0	6.0	5.6	4.8
65.0	5.9	6.0	5.8	5.4	4.7
70.0	4.4	5.4	5.6	5.1	4.7
75.0	3.2	4.0	4.7	4.8	
80.0	2.1	2.7	3.3	3.9	
85.0		1.6	2.0		
危険角度 (°)	35	36	37	45	60
フック種類	12t	12t	12t	12t	12t
フック質量 (t)	0.53	0.53	0.53	0.53	0.53
掛数	1	1	1	1	1

HA性能 45mブーム+4.4m+54mヘビーリフトジブ

オフセット	10°	20°	30°	45°	60°
作業半径 (m)	荷重 (ton)	荷重 (ton)	荷重 (ton)	荷重 (ton)	荷重 (ton)
24.0	5.5				
26.0	5.5				
28.0	5.5				
30.0	5.5				
32.0	5.5	5.5			
34.0	5.5	5.5			
36.0	5.5	5.5			
38.0	5.5	5.5			
40.0	5.5	5.5	5.5		
42.0	5.5	5.5	5.5		
44.0	5.5	5.5	5.5		
46.0	5.5	5.5	5.5		
48.0	5.5	5.5	5.5		
50.0	5.5	5.5	5.5	5.5	
55.0	5.5	5.5	5.5	5.3	
60.0	5.5	5.5	5.5	5.1	3.8
65.0	5.5	5.5	5.5	5.0	3.8
70.0	4.0	5.0	5.5	4.9	3.8
75.0	2.8	3.6	4.4	4.9	3.8
80.0	1.7	2.4	3.1	3.8	
85.0			1.8	2.3	
危険角度 (°)	40	44	44	45	60
フック種類	12t	12t	12t	12t	12t
フック質量 (t)	0.53	0.53	0.53	0.53	0.53
掛数	1	1	1	1	1

HA性能 50mブーム+4.4m+54mヘビーリフトジブ

オフセット	10°	20°	30°	45°	60°
作業半径 (m)	荷重 (ton)	荷重 (ton)	荷重 (ton)	荷重 (ton)	荷重 (ton)
24.0	4.1				
26.0	4.1				
28.0	4.1				
30.0	4.1				
32.0	4.1	4.0			
34.0	4.1	4.0			
36.0	4.1	4.0			
38.0	4.1	4.0			
40.0	4.1	4.0	3.8		
42.0	4.1	4.0	3.7		
44.0	4.1	4.0	3.6		
46.0	4.1	4.0	3.5		
48.0	4.1	4.0	3.4		
50.0	4.1	3.9	3.3	2.3	
55.0	4.1	3.7	3.1	2.2	
60.0	4.0	3.5	2.9	2.1	
65.0	3.8	3.3	2.8	2.0	
70.0	3.2	3.2	2.7	2.0	
75.0	2.4	3.0	2.7	2.0	
80.0		2.1	2.6	2.0	
85.0			1.6	2.0	
危険角度 (°)	47	47	48	50	
フック種類	12t	12t	12t	12t	
フック質量 (t)	0.53	0.53	0.53	0.53	
掛数	1	1	1	1	

HA性能 53.9mブーム+4.4m+54mヘビーリフトジブ

オフセット	10°	20°	30°	45°	60°
作業半径 (m)	荷重 (ton)	荷重 (ton)	荷重 (ton)	荷重 (ton)	荷重 (ton)
24.0	3.5				
26.0	3.5				
28.0	3.5				
30.0	3.5				
32.0	3.5				
34.0	3.5	3.3			
36.0	3.5	3.1			
38.0	3.5	3.0			
40.0	3.5	2.9	2.2		
42.0	3.4	2.8	2.1		
44.0	3.3	2.7	2.0		
46.0	3.2	2.5	2.0		
48.0	3.0	2.5	1.9		
50.0	2.9	2.4	1.8		
55.0	2.7	2.2	1.7		
60.0	2.5	2.0	1.6		
65.0	2.3	1.9			
70.0	2.0	1.9			
75.0		1.8			
危険角度 (°)	53	54	67		
フック種類	12t	12t	12t		
フック質量 (t)	0.53	0.53	0.53		
掛数	1	1	1		

HB性能 14.4mブーム+4.4m+54mヘビーリフトジブ

オフセット	10°	20°	30°	45°	60°
作業半径 (m)	荷重 (ton)	荷重 (ton)	荷重 (ton)	荷重 (ton)	荷重 (ton)
18.0	9.3				
20.0	9.3				
22.0	9.2				
24.0	9.2				
26.0	9.2				
28.0	9.2	8.9			
30.0	9.0	8.8			
32.0	8.8	8.7			
34.0	8.8	8.6			
36.0	8.8	8.5	7.9		
38.0	8.7	8.1	7.6		
40.0	8.3	7.8	7.3		
42.0	7.9	7.5	7.0		
44.0	7.6	7.2	6.8		
46.0	7.3	6.9	6.6	6.1	
48.0	7.0	6.7	6.4	5.9	
50.0	6.8	6.5	6.2	5.8	
55.0	6.2	6.0	5.7	5.5	5.0
60.0	5.7	5.6	5.4	5.0	4.7
65.0	5.3	5.1	4.9	4.7	
70.0	4.8				
危険角度 (°)	10	20	30	45	60
フック種類	12t	12t	12t	12t	12t
フック質量 (t)	0.53	0.53	0.53	0.53	0.53
掛数	1	1	1	1	1

HB性能 19.55mブーム+4.4m+54mヘビーリフトジブ

オフセット	10°	20°	30°	45°	60°
作業半径 (m)	荷重 (ton)	荷重 (ton)	荷重 (ton)	荷重 (ton)	荷重 (ton)
20.0	9.3				
22.0	9.2				
24.0	9.2				
26.0	9.2				
28.0	9.0	8.9			
30.0	9.0	8.9			
32.0	8.9	8.9			
34.0	8.9	8.8			
36.0	8.9	8.7	8.0		
38.0	8.8	8.4	7.7		
40.0	8.7	8.0	7.5		
42.0	8.3	7.7	7.2		
44.0	8.0	7.5	7.0		
46.0	7.7	7.2	6.7	6.2	
48.0	7.4	7.0	6.5	6.0	
50.0	7.2	6.7	6.3	5.8	
55.0	6.6	6.2	5.9	5.5	5.1
60.0	6.1	5.8	5.6	5.2	4.8
65.0	5.7	5.5	5.2	4.8	
70.0	5.2	5.0	4.8		
75.0	4.8				
危険角度 (°)	10	20	30	45	60
フック種類	12t	12t	12t	12t	12t
フック質量 (t)	0.53	0.53	0.53	0.53	0.53
掛数	1	1	1	1	1

HB性能 23.6mブーム+4.4m+54mヘビーリフトジブ

オフセット	10°	20°	30°	45°	60°
作業半径 (m)	荷重 (ton)	荷重 (ton)	荷重 (ton)	荷重 (ton)	荷重 (ton)
20.0	9.3				
22.0	9.3				
24.0	9.2				
26.0	9.2				
28.0	9.2	9.1			
30.0	9.0	8.9			
32.0	8.9	8.8			
34.0	8.9	8.7			
36.0	8.9	8.6	8.1		
38.0	8.8	8.5	7.8		
40.0	8.7	8.2	7.6		
42.0	8.6	7.9	7.3		
44.0	8.3	7.6	7.1		
46.0	8.0	7.4	6.9	6.2	
48.0	7.7	7.1	6.7	6.0	
50.0	7.4	6.9	6.5	5.9	
55.0	6.8	6.4	6.0	5.6	5.1
60.0	6.3	6.0	5.7	5.3	4.8
65.0	5.9	5.6	5.4	4.9	4.7
70.0	5.2	5.3	5.0	4.7	
75.0	4.0	4.3	4.6		
危険角度 (°)	15	20	30	45	60
フック種類	12t	12t	12t	12t	12t
フック質量 (t)	0.53	0.53	0.53	0.53	0.53
掛数	1	1	1	1	1

HB性能 32mブーム+4.4m+54mヘビーリフトジブ

オフセット	10°	20°	30°	45°	60°
作業半径 (m)	荷重 (ton)	荷重 (ton)	荷重 (ton)	荷重 (ton)	荷重 (ton)
22.0	9.0				
24.0	9.0				
26.0	9.0				
28.0	9.0				
30.0	9.0	8.8			
32.0	9.0	8.7			
34.0	8.9	8.7			
36.0	8.8	8.6			
38.0	8.8	8.6	8.0		
40.0	8.7	8.6	7.7		
42.0	8.6	8.3	7.5		
44.0	8.6	8.0	7.3		
46.0	8.6	7.7	7.1		
48.0	8.3	7.5	6.9	6.1	
50.0	8.0	7.3	6.7	6.0	
55.0	7.4	6.8	6.3	5.7	5.2
60.0	6.8	6.3	5.9	5.5	4.9
65.0	5.7	6.0	5.6	5.2	4.7
70.0	4.3	5.1	5.4	4.9	4.6
75.0	3.1	3.7	4.3	4.7	
80.0	2.0	2.5	2.9		
危険角度 (°)	23	27	30	45	60
フック種類	12t	12t	12t	12t	12t
フック質量 (t)	0.53	0.53	0.53	0.53	0.53
掛数	1	1	1	1	1

HB性能 40mブーム+4.4m+54mヘビーリフトジブ

オフセット	10°	20°	30°	45°	60°
作業半径 (m)	荷重 (ton)	荷重 (ton)	荷重 (ton)	荷重 (ton)	荷重 (ton)
22.0	6.0				
24.0	6.0				
26.0	6.0				
28.0	6.0				
30.0	6.0				
32.0	6.0	6.0			
34.0	6.0	6.0			
36.0	6.0	6.0			
38.0	6.0	6.0	6.0		
40.0	6.0	6.0	6.0		
42.0	6.0	6.0	6.0		
44.0	6.0	6.0	6.0		
46.0	6.0	6.0	6.0		
48.0	6.0	6.0	6.0	6.0	
50.0	6.0	6.0	6.0	6.0	
55.0	6.0	6.0	6.0	5.8	4.9
60.0	6.0	6.0	6.0	5.6	4.8
65.0	4.9	6.0	5.8	5.4	4.7
70.0	3.6	4.5	5.3	5.1	4.7
75.0	2.4	3.2	3.9	4.7	
80.0		2.0	2.5	3.1	
危険角度 (°)	41	42	43	45	60
フック種類	12t	12t	12t	12t	12t
フック質量 (t)	0.53	0.53	0.53	0.53	0.53
掛数	1	1	1	1	1

HB性能 45mブーム+4.4m+54mヘビーリフトジブ

オフセット	10°	20°	30°	45°	60°
作業半径 (m)	荷重 (ton)	荷重 (ton)	荷重 (ton)	荷重 (ton)	荷重 (ton)
24.0	5.5				
26.0	5.5				
28.0	5.5				
30.0	5.5				
32.0	5.5	5.5			
34.0	5.5	5.5			
36.0	5.5	5.5			
38.0	5.5	5.5			
40.0	5.5	5.5	5.5		
42.0	5.5	5.5	5.5		
44.0	5.5	5.5	5.5		
46.0	5.5	5.5	5.5		
48.0	5.5	5.5	5.5		
50.0	5.5	5.5	5.5	5.5	
55.0	5.5	5.5	5.5	5.3	
60.0	5.5	5.5	5.5	5.1	3.8
65.0	4.5	5.5	5.5	5.0	3.8
70.0	3.2	4.2	5.1	4.9	3.8
75.0	2.0	2.8	3.6	4.6	3.8
80.0		1.7	2.3	3.0	
85.0				1.6	
危険角度 (°)	44	46	47	47	60
フック種類	12t	12t	12t	12t	12t
フック質量 (t)	0.53	0.53	0.53	0.53	0.53
掛数	1	1	1	1	1

HB性能 50mブーム+4.4m+54mヘビーリフトジブ

オフセット	10°	20°	30°	45°	60°
作業半径 (m)	荷重 (ton)	荷重 (ton)	荷重 (ton)	荷重 (ton)	荷重 (ton)
24.0	4.1				
26.0	4.1				
28.0	4.1				
30.0	4.1				
32.0	4.1	4.0			
34.0	4.1	4.0			
36.0	4.1	4.0			
38.0	4.1	4.0			
40.0	4.1	4.0	3.8		
42.0	4.1	4.0	3.7		
44.0	4.1	4.0	3.6		
46.0	4.1	4.0	3.5		
48.0	4.1	4.0	3.4		
50.0	4.1	3.9	3.3	2.3	
55.0	4.1	3.7	3.1	2.2	
60.0	4.0	3.5	2.9	2.1	
65.0	3.8	3.3	2.8	2.0	
70.0	2.8	3.2	2.7	2.0	
75.0	1.6	2.5	2.7	2.0	
80.0			2.1	2.0	
危険角度 (°)	49	52	52	54	
フック種類	12t	12t	12t	12t	
フック質量 (t)	0.53	0.53	0.53	0.53	
掛数	1	1	1	1	

HB性能 53.9mブーム+4.4m+54mヘビーリフトジブ

オフセット	10°	20°	30°	45°	60°
作業半径 (m)	荷重 (ton)	荷重 (ton)	荷重 (ton)	荷重 (ton)	荷重 (ton)
24.0	3.5				
26.0	3.5				
28.0	3.5				
30.0	3.5				
32.0	3.5				
34.0	3.5	3.3			
36.0	3.5	3.1			
38.0	3.5	3.0			
40.0	3.5	2.9	2.2		
42.0	3.4	2.8	2.1		
44.0	3.3	2.7	2.0		
46.0	3.2	2.5	2.0		
48.0	3.0	2.5	1.9		
50.0	2.9	2.4	1.8		
55.0	2.7	2.2	1.7		
60.0	2.5	2.0	1.6		
65.0	2.3	1.9			
70.0	2.0	1.9			
75.0		1.8			
危険角度 (°)	53	54	67		
フック種類	12t	12t	12t		
フック質量 (t)	0.53	0.53	0.53		
掛数	1	1	1		

HC性能 14.4mブーム+4.4m+54mヘビーリフトジブ

オフセット	10°	20°	30°	45°	60°
作業半径 (m)	荷重 (ton)	荷重 (ton)	荷重 (ton)	荷重 (ton)	荷重 (ton)
18.0	9.3				
20.0	9.3				
22.0	9.2				
24.0	9.2				
26.0	9.2				
28.0	9.2	8.9			
30.0	9.0	8.8			
32.0	8.8	8.7			
34.0	8.8	8.6			
36.0	8.8	8.5	7.9		
38.0	8.7	8.1	7.6		
40.0	8.3	7.8	7.3		
42.0	7.9	7.5	7.0		
44.0	7.6	7.2	6.8		
46.0	7.3	6.9	6.6	6.1	
48.0	7.0	6.7	6.4	5.9	
50.0	6.8	6.5	6.2	5.8	
55.0	6.2	6.0	5.7	5.5	5.0
60.0	5.7	5.6	5.4	5.0	4.7
65.0	5.3	5.1	4.9	4.7	
70.0	4.8				
危険角度 (°)	10	20	30	45	60
フック種類	12t	12t	12t	12t	12t
フック質量 (t)	0.53	0.53	0.53	0.53	0.53
掛数	1	1	1	1	1

HC性能 19.55mブーム+4.4m+54mヘビーリフトジブ

オフセット	10°	20°	30°	45°	60°
作業半径 (m)	荷重 (ton)	荷重 (ton)	荷重 (ton)	荷重 (ton)	荷重 (ton)
20.0	9.3				
22.0	9.2				
24.0	9.2				
26.0	9.2				
28.0	9.0	8.9			
30.0	9.0	8.9			
32.0	8.9	8.9			
34.0	8.9	8.8			
36.0	8.9	8.7	8.0		
38.0	8.8	8.4	7.7		
40.0	8.7	8.0	7.5		
42.0	8.3	7.7	7.2		
44.0	8.0	7.5	7.0		
46.0	7.7	7.2	6.7	6.2	
48.0	7.4	7.0	6.5	6.0	
50.0	7.2	6.7	6.3	5.8	
55.0	6.6	6.2	5.9	5.5	5.1
60.0	6.1	5.8	5.6	5.2	4.8
65.0	5.7	5.5	5.2	4.8	
70.0	5.2	5.0	4.8		
75.0	4.2				
危険角度 (°)	10	20	30	45	60
フック種類	12t	12t	12t	12t	12t
フック質量 (t)	0.53	0.53	0.53	0.53	0.53
掛数	1	1	1	1	1

HC性能 23.6mブーム+4.4m+54mヘビーリフトジブ

オフセット	10°	20°	30°	45°	60°
作業半径 (m)	荷重 (ton)	荷重 (ton)	荷重 (ton)	荷重 (ton)	荷重 (ton)
20.0	9.3				
22.0	9.3				
24.0	9.2				
26.0	9.2				
28.0	9.2	9.1			
30.0	9.0	8.9			
32.0	8.9	8.8			
34.0	8.9	8.7			
36.0	8.9	8.6	8.1		
38.0	8.8	8.5	7.8		
40.0	8.7	8.2	7.6		
42.0	8.6	7.9	7.3		
44.0	8.3	7.6	7.1		
46.0	8.0	7.4	6.9	6.2	
48.0	7.7	7.1	6.7	6.0	
50.0	7.4	6.9	6.5	5.9	
55.0	6.8	6.4	6.0	5.6	5.1
60.0	6.3	6.0	5.7	5.3	4.8
65.0	5.6	5.6	5.4	4.9	4.7
70.0	4.3	4.9	5.0	4.7	
75.0	3.2	3.5	3.8		
危険角度 (°)	15	20	30	45	60
フック種類	12t	12t	12t	12t	12t
フック質量 (t)	0.53	0.53	0.53	0.53	0.53
掛数	1	1	1	1	1

HC性能 32mブーム+4.4m+54mヘビーリフトジブ

オフセット	10°	20°	30°	45°	60°
作業半径 (m)	荷重 (ton)	荷重 (ton)	荷重 (ton)	荷重 (ton)	荷重 (ton)
22.0	9.0				
24.0	9.0				
26.0	9.0				
28.0	9.0				
30.0	9.0	8.8			
32.0	9.0	8.7			
34.0	8.9	8.7			
36.0	8.8	8.6			
38.0	8.8	8.6	8.0		
40.0	8.7	8.6	7.7		
42.0	8.6	8.3	7.5		
44.0	8.6	8.0	7.3		
46.0	8.6	7.7	7.1		
48.0	8.3	7.5	6.9	6.1	
50.0	8.0	7.3	6.7	6.0	
55.0	7.4	6.8	6.3	5.7	5.2
60.0	6.3	6.3	5.9	5.5	4.9
65.0	4.7	5.6	5.6	5.2	4.7
70.0	3.4	4.2	4.9	4.9	4.6
75.0	2.3	2.9	3.5	4.1	
80.0		1.7	2.1		
危険角度 (°)	33	33	35	45	60
フック種類	12t	12t	12t	12t	12t
フック質量 (t)	0.53	0.53	0.53	0.53	0.53
掛数	1	1	1	1	1

HC性能 40mブーム+4.4m+54mヘビーリフトジブ

オフセット	10°	20°	30°	45°	60°
作業半径 (m)	荷重 (ton)	荷重 (ton)	荷重 (ton)	荷重 (ton)	荷重 (ton)
22.0	6.0				
24.0	6.0				
26.0	6.0				
28.0	6.0				
30.0	6.0				
32.0	6.0	6.0			
34.0	6.0	6.0			
36.0	6.0	6.0			
38.0	6.0	6.0	6.0		
40.0	6.0	6.0	6.0		
42.0	6.0	6.0	6.0		
44.0	6.0	6.0	6.0		
46.0	6.0	6.0	6.0		
48.0	6.0	6.0	6.0	6.0	
50.0	6.0	6.0	6.0	6.0	
55.0	6.0	6.0	6.0	5.8	4.9
60.0	5.5	6.0	6.0	5.6	4.8
65.0	4.0	5.1	5.8	5.4	4.7
70.0	2.7	3.6	4.5	5.1	4.7
75.0	1.6	2.3	3.1	3.9	
80.0			1.8	2.4	
危険角度 (°)	43	45	45	46	60
フック種類	12t	12t	12t	12t	12t
フック質量 (t)	0.53	0.53	0.53	0.53	0.53
掛数	1	1	1	1	1

HC性能 45mブーム+4.4m+54mヘビーリフトジブ

オフセット	10°	20°	30°	45°	60°
作業半径 (m)	荷重 (ton)	荷重 (ton)	荷重 (ton)	荷重 (ton)	荷重 (ton)
24.0	5.5				
26.0	5.5				
28.0	5.5				
30.0	5.5				
32.0	5.5	5.5			
34.0	5.5	5.5			
36.0	5.5	5.5			
38.0	5.5	5.5			
40.0	5.5	5.5	5.5		
42.0	5.5	5.5	5.5		
44.0	5.5	5.5	5.5		
46.0	5.5	5.5	5.5		
48.0	5.5	5.5	5.5		
50.0	5.5	5.5	5.5	5.5	
55.0	5.5	5.5	5.5	5.3	
60.0	5.1	5.5	5.5	5.1	3.8
65.0	3.6	4.7	5.5	5.0	3.8
70.0	2.3	3.3	4.2	4.9	3.8
75.0		2.0	2.8	3.8	3.8
80.0				2.3	
危険角度 (°)	49	49	52	52	60
フック種類	12t	12t	12t	12t	12t
フック質量 (t)	0.53	0.53	0.53	0.53	0.53
掛数	1	1	1	1	1

HC性能 50mブーム+4.4m+54mヘビーリフトジブ

オフセット	10°	20°	30°	45°	60°
作業半径 (m)	荷重 (ton)	荷重 (ton)	荷重 (ton)	荷重 (ton)	荷重 (ton)
24.0	4.1				
26.0	4.1				
28.0	4.1				
30.0	4.1				
32.0	4.1	4.0			
34.0	4.1	4.0			
36.0	4.1	4.0			
38.0	4.1	4.0			
40.0	4.1	4.0	3.8		
42.0	4.1	4.0	3.7		
44.0	4.1	4.0	3.6		
46.0	4.1	4.0	3.5		
48.0	4.1	4.0	3.4		
50.0	4.1	3.9	3.3	2.3	
55.0	4.1	3.7	3.1	2.2	
60.0	4.0	3.5	2.9	2.1	
65.0	3.2	3.3	2.8	2.0	
70.0	1.9	3.0	2.7	2.0	
75.0		1.7	2.6	2.0	
80.0				2.0	
危険角度 (°)	51	53	55	55	
フック種類	12t	12t	12t	12t	
フック質量 (t)	0.53	0.53	0.53	0.53	
掛数	1	1	1	1	

HC性能 53.9mブーム+4.4m+54mヘビーリフトジブ

オフセット	10°	20°	30°	45°	60°
作業半径 (m)	荷重 (ton)	荷重 (ton)	荷重 (ton)	荷重 (ton)	荷重 (ton)
24.0	3.5				
26.0	3.5				
28.0	3.5				
30.0	3.5				
32.0	3.5				
34.0	3.5	3.3			
36.0	3.5	3.1			
38.0	3.5	3.0			
40.0	3.5	2.9	2.2		
42.0	3.4	2.8	2.1		
44.0	3.3	2.7	2.0		
46.0	3.2	2.5	2.0		
48.0	3.0	2.5	1.9		
50.0	2.9	2.4	1.8		
55.0	2.7	2.2	1.7		
60.0	2.5	2.0	1.6		
65.0	2.3	1.9			
70.0	1.7	1.9			
危険角度 (°)	54	57	67		
フック種類	12t	12t	12t		
フック質量 (t)	0.53	0.53	0.53		
掛数	1	1	1		

HD性能 14.4mブーム+4.4m+54mヘビーリフトジブ

オフセット	10°	20°	30°	45°	60°
作業半径 (m)	荷重 (ton)	荷重 (ton)	荷重 (ton)	荷重 (ton)	荷重 (ton)
18.0	9.3				
20.0	9.3				
22.0	9.2				
24.0	9.2				
26.0	9.2				
28.0	9.2	8.9			
30.0	9.0	8.8			
32.0	8.8	8.7			
34.0	8.8	8.6			
36.0	8.8	8.5	7.9		
38.0	8.7	8.1	7.6		
40.0	8.3	7.8	7.3		
42.0	7.9	7.5	7.0		
44.0	7.6	7.2	6.8		
46.0	7.3	6.9	6.6	6.1	
48.0	7.0	6.7	6.4	5.9	
50.0	6.8	6.5	6.2	5.8	
55.0	6.2	6.0	5.7	5.5	5.0
60.0	5.7	5.6	5.4	5.0	4.7
65.0	5.3	5.1	4.9	4.7	
70.0	4.8				
危険角度 (°)	10	20	30	45	60
フック種類	12t	12t	12t	12t	12t
フック質量 (t)	0.53	0.53	0.53	0.53	0.53
掛数	1	1	1	1	1

HD性能 19.55mブーム+4.4m+54mヘビーリフトジブ

オフセット	10°	20°	30°	45°	60°
作業半径 (m)	荷重 (ton)	荷重 (ton)	荷重 (ton)	荷重 (ton)	荷重 (ton)
20.0	9.3				
22.0	9.2				
24.0	9.2				
26.0	9.2				
28.0	9.0	8.9			
30.0	9.0	8.9			
32.0	8.9	8.9			
34.0	8.9	8.8			
36.0	8.9	8.7	8.0		
38.0	8.8	8.4	7.7		
40.0	8.7	8.0	7.5		
42.0	8.3	7.7	7.2		
44.0	8.0	7.5	7.0		
46.0	7.7	7.2	6.7	6.2	
48.0	7.4	7.0	6.5	6.0	
50.0	7.2	6.7	6.3	5.8	
55.0	6.6	6.2	5.9	5.5	5.1
60.0	6.1	5.8	5.6	5.2	4.8
65.0	5.7	5.5	5.2	4.8	
70.0	4.5	4.9	4.8		
75.0	3.4				
危険角度 (°)	10	20	30	45	60
フック種類	12t	12t	12t	12t	12t
フック質量 (t)	0.53	0.53	0.53	0.53	0.53
掛数	1	1	1	1	1

HD性能 23.6mブーム+4.4m+54mヘビーリフトジブ

オフセット	10°	20°	30°	45°	60°
作業半径 (m)	荷重 (ton)	荷重 (ton)	荷重 (ton)	荷重 (ton)	荷重 (ton)
20.0	9.3				
22.0	9.3				
24.0	9.2				
26.0	9.2				
28.0	9.2	9.1			
30.0	9.0	8.9			
32.0	8.9	8.8			
34.0	8.9	8.7			
36.0	8.9	8.6	8.1		
38.0	8.8	8.5	7.8		
40.0	8.7	8.2	7.6		
42.0	8.6	7.9	7.3		
44.0	8.3	7.6	7.1		
46.0	8.0	7.4	6.9	6.2	
48.0	7.7	7.1	6.7	6.0	
50.0	7.4	6.9	6.5	5.9	
55.0	6.8	6.4	6.0	5.6	5.1
60.0	6.1	6.0	5.7	5.3	4.8
65.0	4.7	5.4	5.4	4.9	4.7
70.0	3.5	4.0	4.5	4.7	
75.0	2.4	2.7	3.0		
危険角度 (°)	20	20	30	45	60
フック種類	12t	12t	12t	12t	12t
フック質量 (t)	0.53	0.53	0.53	0.53	0.53
掛数	1	1	1	1	1

HD性能 32mブーム+4.4m+54mヘビーリフトジブ

オフセット	10°	20°	30°	45°	60°
作業半径 (m)	荷重 (ton)	荷重 (ton)	荷重 (ton)	荷重 (ton)	荷重 (ton)
22.0	9.0				
24.0	9.0				
26.0	9.0				
28.0	9.0				
30.0	9.0	8.8			
32.0	9.0	8.7			
34.0	8.9	8.7			
36.0	8.8	8.6			
38.0	8.8	8.6	8.0		
40.0	8.7	8.6	7.7		
42.0	8.6	8.3	7.5		
44.0	8.6	8.0	7.3		
46.0	8.6	7.7	7.1		
48.0	8.3	7.5	6.9	6.1	
50.0	8.0	7.3	6.7	6.0	
55.0	6.9	6.8	6.3	5.7	5.2
60.0	5.2	6.3	5.9	5.5	4.9
65.0	3.8	4.7	5.6	5.2	4.7
70.0	2.6	3.3	4.0	4.9	4.6
75.0		2.1	2.6	3.2	
危険角度 (°)	39	39	41	45	60
フック種類	12t	12t	12t	12t	12t
フック質量 (t)	0.53	0.53	0.53	0.53	0.53
掛数	1	1	1	1	1

HD性能 40mブーム+4.4m+54mヘビーリフトジブ

オフセット	10°	20°	30°	45°	60°
作業半径 (m)	荷重 (ton)	荷重 (ton)	荷重 (ton)	荷重 (ton)	荷重 (ton)
22.0	6.0				
24.0	6.0				
26.0	6.0				
28.0	6.0				
30.0	6.0				
32.0	6.0	6.0			
34.0	6.0	6.0			
36.0	6.0	6.0			
38.0	6.0	6.0	6.0		
40.0	6.0	6.0	6.0		
42.0	6.0	6.0	6.0		
44.0	6.0	6.0	6.0		
46.0	6.0	6.0	6.0		
48.0	6.0	6.0	6.0	6.0	
50.0	6.0	6.0	6.0	6.0	
55.0	6.0	6.0	6.0	5.8	4.9
60.0	4.5	5.7	6.0	5.6	4.8
65.0	3.1	4.1	5.2	5.4	4.7
70.0	1.8	2.8	3.6	4.7	4.7
75.0			2.2	3.1	
80.0				1.6	
危険角度 (°)	47	50	50	50	60
フック種類	12t	12t	12t	12t	12t
フック質量 (t)	0.53	0.53	0.53	0.53	0.53
掛数	1	1	1	1	1

HD性能 45mブーム+4.4m+54mヘビーリフトジブ

オフセット	10°	20°	30°	45°	60°
作業半径 (m)	荷重 (ton)	荷重 (ton)	荷重 (ton)	荷重 (ton)	荷重 (ton)
24.0	5.5				
26.0	5.5				
28.0	5.5				
30.0	5.5				
32.0	5.5	5.5			
34.0	5.5	5.5			
36.0	5.5	5.5			
38.0	5.5	5.5			
40.0	5.5	5.5	5.5		
42.0	5.5	5.5	5.5		
44.0	5.5	5.5	5.5		
46.0	5.5	5.5	5.5		
48.0	5.5	5.5	5.5		
50.0	5.5	5.5	5.5	5.5	
55.0	5.5	5.5	5.5	5.3	
60.0	4.1	5.4	5.5	5.1	3.8
65.0	2.7	3.8	4.9	5.0	3.8
70.0		2.4	3.4	4.6	3.8
75.0			2.0	3.0	3.5
危険角度 (°)	53	53	54	56	60
フック種類	12t	12t	12t	12t	12t
フック質量 (t)	0.53	0.53	0.53	0.53	0.53
掛数	1	1	1	1	1

HD性能 50mブーム+4.4m+54mヘビーリフトジブ

オフセット	10°	20°	30°	45°	60°
作業半径 (m)	荷重 (ton)	荷重 (ton)	荷重 (ton)	荷重 (ton)	荷重 (ton)
24.0	4.1				
26.0	4.1				
28.0	4.1				
30.0	4.1				
32.0	4.1	4.0			
34.0	4.1	4.0			
36.0	4.1	4.0			
38.0	4.1	4.0			
40.0	4.1	4.0	3.8		
42.0	4.1	4.0	3.7		
44.0	4.1	4.0	3.6		
46.0	4.1	4.0	3.5		
48.0	4.1	4.0	3.4		
50.0	4.1	3.9	3.3	2.3	
55.0	4.1	3.7	3.1	2.2	
60.0	3.7	3.5	2.9	2.1	
65.0	2.3	3.3	2.8	2.0	
70.0		2.1	2.7	2.0	
75.0			1.8	2.0	
危険角度 (°)	55	56	56	59	
フック種類	12t	12t	12t	12t	
フック質量 (t)	0.53	0.53	0.53	0.53	
掛数	1	1	1	1	

HD性能 53.9mブーム+4.4m+54mヘビーリフトジブ

オフセット	10°	20°	30°	45°	60°
作業半径 (m)	荷重 (ton)	荷重 (ton)	荷重 (ton)	荷重 (ton)	荷重 (ton)
24.0	3.5				
26.0	3.5				
28.0	3.5				
30.0	3.5				
32.0	3.5				
34.0	3.5	3.3			
36.0	3.5	3.1			
38.0	3.5	3.0			
40.0	3.5	2.9	2.2		
42.0	3.4	2.8	2.1		
44.0	3.3	2.7	2.0		
46.0	3.2	2.5	2.0		
48.0	3.0	2.5	1.9		
50.0	2.9	2.4	1.8		
55.0	2.7	2.2	1.7		
60.0	2.5	2.0	1.6		
65.0	2.0	1.9			
70.0		1.9			
危険角度 (°)	57	58	67		
フック種類	12t	12t	12t		
フック質量 (t)	0.53	0.53	0.53		
掛数	1	1	1		

HE性能 14.4mブーム+4.4m+54mヘビーリフトジブ

オフセット	10°	20°	30°	45°	60°
作業半径 (m)	荷重 (ton)	荷重 (ton)	荷重 (ton)	荷重 (ton)	荷重 (ton)
18.0	9.3				
20.0	9.3				
22.0	9.2				
24.0	9.2				
26.0	9.2				
28.0	9.2	8.9			
30.0	9.0	8.8			
32.0	8.8	8.7			
34.0	8.8	8.6			
36.0	8.8	8.5	7.9		
38.0	8.7	8.1	7.6		
40.0	8.3	7.8	7.3		
42.0	7.9	7.5	7.0		
44.0	7.6	7.2	6.8		
46.0	7.3	6.9	6.6	6.1	
48.0	7.0	6.7	6.4	5.9	
50.0	6.8	6.5	6.2	5.8	
55.0	6.2	6.0	5.7	5.5	5.0
60.0	5.7	5.6	5.4	5.0	4.7
65.0	5.3	5.1	4.9	4.7	
70.0	4.8				
危険角度 (°)	10	20	30	45	60
フック種類	12t	12t	12t	12t	12t
フック質量 (t)	0.53	0.53	0.53	0.53	0.53
掛数	1	1	1	1	1

HE性能 19.55mブーム+4.4m+54mヘビーリフトジブ

オフセット	10°	20°	30°	45°	60°
作業半径 (m)	荷重 (ton)	荷重 (ton)	荷重 (ton)	荷重 (ton)	荷重 (ton)
20.0	9.3				
22.0	9.2				
24.0	9.2				
26.0	9.2				
28.0	9.0	8.9			
30.0	9.0	8.9			
32.0	8.9	8.9			
34.0	8.9	8.8			
36.0	8.9	8.7	8.0		
38.0	8.8	8.4	7.7		
40.0	8.7	8.0	7.5		
42.0	8.3	7.7	7.2		
44.0	8.0	7.5	7.0		
46.0	7.7	7.2	6.7	6.2	
48.0	7.4	7.0	6.5	6.0	
50.0	7.2	6.7	6.3	5.8	
55.0	6.6	6.2	5.9	5.5	5.1
60.0	5.7	5.8	5.6	5.2	4.8
65.0	4.4	4.9	5.2	4.8	
70.0	3.2	3.6	4.0		
75.0	2.2				
危険角度 (°)	10	20	30	45	60
フック種類	12t	12t	12t	12t	12t
フック質量 (t)	0.53	0.53	0.53	0.53	0.53
掛数	1	1	1	1	1

HE性能 23.6mブーム+4.4m+54mヘビーリフトジブ

オフセット	10°	20°	30°	45°	60°
作業半径 (m)	荷重 (ton)	荷重 (ton)	荷重 (ton)	荷重 (ton)	荷重 (ton)
20.0	9.3				
22.0	9.3				
24.0	9.2				
26.0	9.2				
28.0	9.2	9.1			
30.0	9.0	8.9			
32.0	8.9	8.8			
34.0	8.9	8.7			
36.0	8.9	8.6	8.1		
38.0	8.8	8.5	7.8		
40.0	8.7	8.2	7.6		
42.0	8.6	7.9	7.3		
44.0	8.3	7.6	7.1		
46.0	8.0	7.4	6.9	6.2	
48.0	7.7	7.1	6.7	6.0	
50.0	7.4	6.9	6.5	5.9	
55.0	6.2	6.4	6.0	5.6	5.1
60.0	4.6	5.5	5.7	5.3	4.8
65.0	3.3	4.0	4.7	4.9	4.7
70.0	2.2	2.7	3.2	3.8	
75.0			1.8		
危険角度 (°)	28	33	34	45	60
フック種類	12t	12t	12t	12t	12t
フック質量 (t)	0.53	0.53	0.53	0.53	0.53
掛数	1	1	1	1	1

HE性能 32mブーム+4.4m+54mヘビーリフトジブ

オフセット	10°	20°	30°	45°	60°
作業半径 (m)	荷重 (ton)	荷重 (ton)	荷重 (ton)	荷重 (ton)	荷重 (ton)
22.0	9.0				
24.0	9.0				
26.0	9.0				
28.0	9.0				
30.0	9.0	8.8			
32.0	9.0	8.7			
34.0	8.9	8.7			
36.0	8.8	8.6			
38.0	8.8	8.6	8.0		
40.0	8.7	8.6	7.7		
42.0	8.6	8.3	7.5		
44.0	8.6	8.0	7.3		
46.0	8.6	7.7	7.1		
48.0	8.0	7.5	6.9	6.1	
50.0	7.1	7.3	6.7	6.0	
55.0	5.3	6.5	6.3	5.7	5.2
60.0	3.7	4.8	5.8	5.5	4.9
65.0	2.4	3.3	4.2	5.2	4.7
70.0		2.0	2.7	3.7	4.1
75.0				2.0	
危険角度 (°)	45	45	48	48	60
フック種類	12t	12t	12t	12t	12t
フック質量 (t)	0.53	0.53	0.53	0.53	0.53
掛数	1	1	1	1	1

HE性能 40mブーム+4.4m+54mヘビーリフトジブ

オフセット	10°	20°	30°	45°	60°
作業半径 (m)	荷重 (ton)	荷重 (ton)	荷重 (ton)	荷重 (ton)	荷重 (ton)
22.0	6.0				
24.0	6.0				
26.0	6.0				
28.0	6.0				
30.0	6.0				
32.0	6.0	6.0			
34.0	6.0	6.0			
36.0	6.0	6.0			
38.0	6.0	6.0	6.0		
40.0	6.0	6.0	6.0		
42.0	6.0	6.0	6.0		
44.0	6.0	6.0	6.0		
46.0	6.0	6.0	6.0		
48.0	6.0	6.0	6.0	6.0	
50.0	6.0	6.0	6.0	6.0	
55.0	4.5	6.0	6.0	5.8	4.9
60.0	3.0	4.2	5.4	5.6	4.8
65.0	1.7	2.7	3.7	5.1	4.7
70.0			2.3	3.4	4.1
75.0				1.9	
危険角度 (°)	51	55	55	55	60
フック種類	12t	12t	12t	12t	12t
フック質量 (t)	0.53	0.53	0.53	0.53	0.53
掛数	1	1	1	1	1

HE性能 45mブーム+4.4m+54mヘビーリフトジブ

オフセット	10°	20°	30°	45°	60°
作業半径 (m)	荷重 (ton)	荷重 (ton)	荷重 (ton)	荷重 (ton)	荷重 (ton)
24.0	5.5				
26.0	5.5				
28.0	5.5				
30.0	5.5				
32.0	5.5	5.5			
34.0	5.5	5.5			
36.0	5.5	5.5			
38.0	5.5	5.5			
40.0	5.5	5.5	5.5		
42.0	5.5	5.5	5.5		
44.0	5.5	5.5	5.5		
46.0	5.5	5.5	5.5		
48.0	5.5	5.5	5.5		
50.0	5.5	5.5	5.5	5.5	
55.0	4.1	5.5	5.5	5.3	
60.0	2.6	3.9	5.2	5.1	3.8
65.0		2.4	3.5	5.0	3.8
70.0			2.1	3.3	3.8
75.0				1.8	2.3
危険角度 (°)	56	57	57	58	60
フック種類	12t	12t	12t	12t	12t
フック質量 (t)	0.53	0.53	0.53	0.53	0.53
掛数	1	1	1	1	1

HE性能 50mブーム+4.4m+54mヘビーリフトジブ

オフセット	10°	20°	30°	45°	60°
作業半径 (m)	荷重 (ton)	荷重 (ton)	荷重 (ton)	荷重 (ton)	荷重 (ton)
24.0	4.1				
26.0	4.1				
28.0	4.1				
30.0	4.1				
32.0	4.1	4.0			
34.0	4.1	4.0			
36.0	4.1	4.0			
38.0	4.1	4.0			
40.0	4.1	4.0	3.8		
42.0	4.1	4.0	3.7		
44.0	4.1	4.0	3.6		
46.0	4.1	4.0	3.5		
48.0	4.1	4.0	3.4		
50.0	4.1	3.9	3.3	2.3	
55.0	3.8	3.7	3.1	2.2	
60.0	2.2	3.5	2.9	2.1	
65.0		2.1	2.8	2.0	
70.0			1.8	2.0	
75.0				1.7	
危険角度 (°)	58	59	60	61	
フック種類	12t	12t	12t	12t	
フック質量 (t)	0.53	0.53	0.53	0.53	
掛数	1	1	1	1	

HE性能 53.9mブーム+4.4m+54mヘビーリフトジブ

オフセット	10°	20°	30°	45°	60°
作業半径 (m)	荷重 (ton)	荷重 (ton)	荷重 (ton)	荷重 (ton)	荷重 (ton)
24.0	3.5				
26.0	3.5				
28.0	3.5				
30.0	3.5				
32.0	3.5				
34.0	3.5	3.3			
36.0	3.5	3.1			
38.0	3.5	3.0			
40.0	3.5	2.9	2.2		
42.0	3.4	2.8	2.1		
44.0	3.3	2.7	2.0		
46.0	3.2	2.5	2.0		
48.0	3.0	2.5	1.9		
50.0	2.9	2.4	1.8		
55.0	2.7	2.2	1.7		
60.0	1.9	2.0	1.6		
65.0		1.9			
危険角度 (°)	60	61	67		
フック種類	12t	12t	12t		
フック質量 (t)	0.53	0.53	0.53		
掛数	1	1	1		

HF性能 14.4mブーム+4.4m+54mヘビーリフトジブ

オフセット	10°	20°	30°	45°	60°
作業半径 (m)	荷重 (ton)	荷重 (ton)	荷重 (ton)	荷重 (ton)	荷重 (ton)
18.0	9.3				
20.0	9.3				
22.0	9.2				
24.0	9.2				
26.0	9.2				
28.0	9.2	8.9			
30.0	9.0	8.8			
32.0	8.8	8.7			
34.0	8.8	8.6			
36.0	8.8	8.5	7.9		
38.0	8.7	8.1	7.6		
40.0	8.3	7.8	7.3		
42.0	7.9	7.5	7.0		
44.0	7.6	7.2	6.8		
46.0	7.3	6.9	6.6	6.1	
48.0	7.0	6.7	6.4	5.9	
50.0	6.8	6.5	6.2	5.8	
55.0	6.2	6.0	5.7	5.5	5.0
60.0	5.7	5.6	5.4	5.0	4.7
65.0	5.1	5.1	4.9	4.7	
70.0	4.0				
危険角度 (°)	10	20	30	45	60
フック種類	12t	12t	12t	12t	12t
フック質量 (t)	0.53	0.53	0.53	0.53	0.53
掛数	1	1	1	1	1

HF性能 19.55mブーム+4.4m+54mヘビーリフトジブ

オフセット	10°	20°	30°	45°	60°
作業半径 (m)	荷重 (ton)	荷重 (ton)	荷重 (ton)	荷重 (ton)	荷重 (ton)
20.0	9.3				
22.0	9.2				
24.0	9.2				
26.0	9.2				
28.0	9.0	8.9			
30.0	9.0	8.9			
32.0	8.9	8.9			
34.0	8.9	8.8			
36.0	8.9	8.7	8.0		
38.0	8.8	8.4	7.7		
40.0	8.7	8.0	7.5		
42.0	8.3	7.7	7.2		
44.0	8.0	7.5	7.0		
46.0	7.7	7.2	6.7	6.2	
48.0	7.4	7.0	6.5	6.0	
50.0	7.2	6.7	6.3	5.8	
55.0	6.2	6.2	5.9	5.5	5.1
60.0	4.8	5.5	5.6	5.2	4.8
65.0	3.5	4.1	4.6	4.8	
70.0	2.5	2.8	3.2		
危険角度 (°)	18	20	30	45	60
フック種類	12t	12t	12t	12t	12t
フック質量 (t)	0.53	0.53	0.53	0.53	0.53
掛数	1	1	1	1	1

HF性能 23.6mブーム+4.4m+54mヘビーリフトジブ

オフセット	10°	20°	30°	45°	60°
作業半径 (m)	荷重 (ton)	荷重 (ton)	荷重 (ton)	荷重 (ton)	荷重 (ton)
20.0	9.3				
22.0	9.3				
24.0	9.2				
26.0	9.2				
28.0	9.2	9.1			
30.0	9.0	8.9			
32.0	8.9	8.8			
34.0	8.9	8.7			
36.0	8.9	8.6	8.1		
38.0	8.8	8.5	7.8		
40.0	8.7	8.2	7.6		
42.0	8.6	7.9	7.3		
44.0	8.3	7.6	7.1		
46.0	8.0	7.4	6.9	6.2	
48.0	7.7	7.1	6.7	6.0	
50.0	6.9	6.9	6.5	5.9	
55.0	5.1	6.2	6.0	5.6	5.1
60.0	3.7	4.6	5.4	5.3	4.8
65.0	2.4	3.2	3.9	4.8	4.7
70.0		1.9	2.4	3.0	
危険角度 (°)	37	37	38	45	60
フック種類	12t	12t	12t	12t	12t
フック質量 (t)	0.53	0.53	0.53	0.53	0.53
掛数	1	1	1	1	1

HF性能 32mブーム+4.4m+54mヘビーリフトジブ

オフセット	10°	20°	30°	45°	60°
作業半径 (m)	荷重 (ton)	荷重 (ton)	荷重 (ton)	荷重 (ton)	荷重 (ton)
22.0	9.0				
24.0	9.0				
26.0	9.0				
28.0	9.0				
30.0	9.0	8.8			
32.0	9.0	8.7			
34.0	8.9	8.7			
36.0	8.8	8.6			
38.0	8.8	8.6	8.0		
40.0	8.7	8.6	7.7		
42.0	8.6	8.3	7.5		
44.0	8.6	8.0	7.3		
46.0	7.7	7.7	7.1		
48.0	6.8	7.5	6.9	6.1	
50.0	6.0	7.3	6.7	6.0	
55.0	4.3	5.5	6.3	5.7	5.2
60.0	2.8	3.9	4.9	5.5	4.9
65.0		2.5	3.3	4.5	4.7
70.0			1.9	2.9	3.3
危険角度 (°)	50	50	51	52	60
フック種類	12t	12t	12t	12t	12t
フック質量 (t)	0.53	0.53	0.53	0.53	0.53
掛数	1	1	1	1	1

HF性能 40mブーム+4.4m+54mヘビーリフトジブ

オフセット	10°	20°	30°	45°	60°
作業半径 (m)	荷重 (ton)	荷重 (ton)	荷重 (ton)	荷重 (ton)	荷重 (ton)
22.0	6.0				
24.0	6.0				
26.0	6.0				
28.0	6.0				
30.0	6.0				
32.0	6.0	6.0			
34.0	6.0	6.0			
36.0	6.0	6.0			
38.0	6.0	6.0	6.0		
40.0	6.0	6.0	6.0		
42.0	6.0	6.0	6.0		
44.0	6.0	6.0	6.0		
46.0	6.0	6.0	6.0		
48.0	6.0	6.0	6.0	6.0	
50.0	5.3	6.0	6.0	6.0	
55.0	3.5	4.9	6.0	5.8	4.9
60.0	2.1	3.3	4.5	5.6	4.8
65.0		1.9	2.9	4.3	4.7
70.0				2.6	3.4
危険角度 (°)	54	56	59	59	61
フック種類	12t	12t	12t	12t	12t
フック質量 (t)	0.53	0.53	0.53	0.53	0.53
掛数	1	1	1	1	1

HF性能 45mブーム+4.4m+54mヘビーリフトジブ

オフセット	10°	20°	30°	45°	60°
作業半径 (m)	荷重 (ton)	荷重 (ton)	荷重 (ton)	荷重 (ton)	荷重 (ton)
24.0	5.5				
26.0	5.5				
28.0	5.5				
30.0	5.5				
32.0	5.5	5.5			
34.0	5.5	5.5			
36.0	5.5	5.5			
38.0	5.5	5.5			
40.0	5.5	5.5	5.5		
42.0	5.5	5.5	5.5		
44.0	5.5	5.5	5.5		
46.0	5.5	5.5	5.5		
48.0	5.5	5.5	5.5		
50.0	4.9	5.5	5.5	5.5	
55.0	3.1	4.6	5.5	5.3	
60.0	1.7	3.0	4.2	5.1	3.8
65.0		1.6	2.6	4.1	3.8
70.0				2.5	3.3
75.0					1.6
危険角度 (°)	57	58	61	62	62
フック種類	12t	12t	12t	12t	12t
フック質量 (t)	0.53	0.53	0.53	0.53	0.53
掛数	1	1	1	1	1

HF性能 50mブーム+4.4m+54mヘビーリフトジブ

オフセット	10°	20°	30°	45°	60°
作業半径 (m)	荷重 (ton)	荷重 (ton)	荷重 (ton)	荷重 (ton)	荷重 (ton)
24.0	4.1				
26.0	4.1				
28.0	4.1				
30.0	4.1				
32.0	4.1	4.0			
34.0	4.1	4.0			
36.0	4.1	4.0			
38.0	4.1	4.0			
40.0	4.1	4.0	3.8		
42.0	4.1	4.0	3.7		
44.0	4.1	4.0	3.6		
46.0	4.1	4.0	3.5		
48.0	4.1	4.0	3.4		
50.0	4.1	3.9	3.3	2.3	
55.0	2.8	3.7	3.1	2.2	
60.0		2.7	2.9	2.1	
65.0			2.4	2.0	
70.0				2.0	
危険角度 (°)	62	63	63	64	
フック種類	12t	12t	12t	12t	
フック質量 (t)	0.53	0.53	0.53	0.53	
掛数	1	1	1	1	

HF性能 53.9mブーム+4.4m+54mヘビーリフトジブ

オフセット	10°	20°	30°	45°	60°
作業半径 (m)	荷重 (ton)	荷重 (ton)	荷重 (ton)	荷重 (ton)	荷重 (ton)
24.0	3.5				
26.0	3.5				
28.0	3.5				
30.0	3.5				
32.0	3.5				
34.0	3.5	3.3			
36.0	3.5	3.1			
38.0	3.5	3.0			
40.0	3.5	2.9	2.2		
42.0	3.4	2.8	2.1		
44.0	3.3	2.7	2.0		
46.0	3.2	2.5	2.0		
48.0	3.0	2.5	1.9		
50.0	2.9	2.4	1.8		
55.0	2.5	2.2	1.7		
60.0		2.0	1.6		
危険角度 (°)	64	65	67		
フック種類	12t	12t	12t		
フック質量 (t)	0.53	0.53	0.53		
掛数	1	1	1		

HG性能 14.4mブーム+4.4m+54mヘビーリフトジブ

オフセット	10°	20°	30°	45°	60°
作業半径 (m)	荷重 (ton)	荷重 (ton)	荷重 (ton)	荷重 (ton)	荷重 (ton)
18.0	9.3				
20.0	9.3				
22.0	9.2				
24.0	9.2				
26.0	9.2				
28.0	9.2	8.9			
30.0	9.0	8.8			
32.0	8.8	8.7			
34.0	8.8	8.6			
36.0	8.8	8.5	7.9		
38.0	8.7	8.1	7.6		
40.0	8.3	7.8	7.3		
42.0	7.9	7.5	7.0		
44.0	7.6	7.2	6.8		
46.0	7.3	6.9	6.6	6.1	
48.0	7.0	6.7	6.4	5.9	
50.0	6.8	6.5	6.2	5.8	
55.0	6.2	6.0	5.7	5.5	5.0
60.0	5.3	5.6	5.4	5.0	4.7
65.0	4.2	4.5	4.8	4.7	
70.0	3.2				
危険角度 (°)	10	20	30	45	60
フック種類	12t	12t	12t	12t	12t
フック質量 (t)	0.53	0.53	0.53	0.53	0.53
掛数	1	1	1	1	1

HG性能 19.55mブーム+4.4m+54mヘビーリフトジブ

オフセット	10°	20°	30°	45°	60°
作業半径 (m)	荷重 (ton)	荷重 (ton)	荷重 (ton)	荷重 (ton)	荷重 (ton)
20.0	9.3				
22.0	9.2				
24.0	9.2				
26.0	9.2				
28.0	9.0	8.9			
30.0	9.0	8.9			
32.0	8.9	8.9			
34.0	8.9	8.8			
36.0	8.9	8.7	8.0		
38.0	8.8	8.4	7.7		
40.0	8.7	8.0	7.5		
42.0	8.3	7.7	7.2		
44.0	8.0	7.5	7.0		
46.0	7.7	7.2	6.7	6.2	
48.0	7.3	7.0	6.5	6.0	
50.0	6.7	6.7	6.3	5.8	
55.0	5.2	5.9	5.9	5.5	5.1
60.0	3.8	4.5	5.2	5.2	4.8
65.0	2.7	3.2	3.8	4.5	
70.0	1.7	2.0	2.4		
危険角度 (°)	25	28	30	45	60
フック種類	12t	12t	12t	12t	12t
フック質量 (t)	0.53	0.53	0.53	0.53	0.53
掛数	1	1	1	1	1

HG性能 23.6mブーム+4.4m+54mヘビーリフトジブ

オフセット	10°	20°	30°	45°	60°
作業半径 (m)	荷重 (ton)	荷重 (ton)	荷重 (ton)	荷重 (ton)	荷重 (ton)
20.0	9.3				
22.0	9.3				
24.0	9.2				
26.0	9.2				
28.0	9.2	9.1			
30.0	9.0	8.9			
32.0	8.9	8.8			
34.0	8.9	8.7			
36.0	8.9	8.6	8.1		
38.0	8.8	8.5	7.8		
40.0	8.7	8.2	7.6		
42.0	8.6	7.9	7.3		
44.0	8.0	7.6	7.1		
46.0	7.3	7.4	6.9	6.2	
48.0	6.5	7.1	6.7	6.0	
50.0	5.8	6.8	6.5	5.9	
55.0	4.1	5.2	6.0	5.6	5.1
60.0	2.8	3.6	4.5	5.3	4.8
65.0	1.6	2.3	3.0	4.0	4.5
70.0			1.6	2.2	
危険角度 (°)	39	42	42	45	60
フック種類	12t	12t	12t	12t	12t
フック質量 (t)	0.53	0.53	0.53	0.53	0.53
掛数	1	1	1	1	1

HG性能 32mブーム+4.4m+54mヘビーリフトジブ

オフセット	10°	20°	30°	45°	60°
作業半径 (m)	荷重 (ton)	荷重 (ton)	荷重 (ton)	荷重 (ton)	荷重 (ton)
22.0	9.0				
24.0	9.0				
26.0	9.0				
28.0	9.0				
30.0	9.0	8.8			
32.0	9.0	8.7			
34.0	8.9	8.7			
36.0	8.8	8.6			
38.0	8.8	8.6	8.0		
40.0	8.7	8.6	7.7		
42.0	8.3	8.3	7.5		
44.0	7.4	8.0	7.3		
46.0	6.5	7.7	7.1		
48.0	5.7	7.1	6.9	6.1	
50.0	4.9	6.3	6.7	6.0	
55.0	3.2	4.5	5.7	5.7	5.2
60.0	1.9	2.9	4.0	5.3	4.9
65.0		1.6	2.5	3.7	4.5
70.0				2.1	2.5
危険角度 (°)	51	52	55	55	60
フック種類	12t	12t	12t	12t	12t
フック質量 (t)	0.53	0.53	0.53	0.53	0.53
掛数	1	1	1	1	1

HG性能 40mブーム+4.4m+54mヘビーリフトジブ

オフセット	10°	20°	30°	45°	60°
作業半径 (m)	荷重 (ton)	荷重 (ton)	荷重 (ton)	荷重 (ton)	荷重 (ton)
22.0	6.0				
24.0	6.0				
26.0	6.0				
28.0	6.0				
30.0	6.0				
32.0	6.0	6.0			
34.0	6.0	6.0			
36.0	6.0	6.0			
38.0	6.0	6.0	6.0		
40.0	6.0	6.0	6.0		
42.0	6.0	6.0	6.0		
44.0	6.0	6.0	6.0		
46.0	5.8	6.0	6.0		
48.0	5.0	6.0	6.0	6.0	
50.0	4.2	5.8	6.0	6.0	
55.0	2.5	3.9	5.3	5.8	4.9
60.0		2.4	3.5	5.1	4.8
65.0			2.0	3.4	4.4
70.0				1.8	2.6
危険角度 (°)	58	59	60	61	63
フック種類	12t	12t	12t	12t	12t
フック質量 (t)	0.53	0.53	0.53	0.53	0.53
掛数	1	1	1	1	1

HG性能 45mブーム+4.4m+54mヘビーリフトジブ

オフセット	10°	20°	30°	45°	60°
作業半径 (m)	荷重 (ton)	荷重 (ton)	荷重 (ton)	荷重 (ton)	荷重 (ton)
24.0	5.5				
26.0	5.5				
28.0	5.5				
30.0	5.5				
32.0	5.5	5.5			
34.0	5.5	5.5			
36.0	5.5	5.5			
38.0	5.5	5.5			
40.0	5.5	5.5	5.5		
42.0	5.5	5.5	5.5		
44.0	5.5	5.5	5.5		
46.0	5.4	5.5	5.5		
48.0	4.6	5.5	5.5		
50.0	3.8	5.5	5.5	5.5	
55.0		3.6	5.1	5.3	
60.0			3.3	5.0	3.8
65.0			1.8	3.3	3.8
70.0				1.7	2.5
危険角度 (°)	63	64	64	65	65
フック種類	12t	12t	12t	12t	12t
フック質量 (t)	0.53	0.53	0.53	0.53	0.53
掛数	1	1	1	1	1

HG性能 50mブーム+4.4m+54mヘビーリフトジブ

オフセット	10°	20°	30°	45°	60°
作業半径 (m)	荷重 (ton)	荷重 (ton)	荷重 (ton)	荷重 (ton)	荷重 (ton)
24.0	4.1				
26.0	4.1				
28.0	4.1				
30.0	4.1				
32.0	4.1	4.0			
34.0	4.1	4.0			
36.0	4.1	4.0			
38.0	4.1	4.0			
40.0	4.1	4.0	3.8		
42.0	4.1	4.0	3.7		
44.0	4.1	4.0	3.6		
46.0	4.1	4.0	3.5		
48.0	4.1	4.0	3.4		
50.0	3.4	3.9	3.3	2.3	
55.0		3.3	3.1	2.2	
60.0			2.9	2.1	
65.0				2.0	
危険角度 (°)	66	67	68	69	
フック種類	12t	12t	12t	12t	
フック質量 (t)	0.53	0.53	0.53	0.53	
掛数	1	1	1	1	

HG性能 53.9mブーム+4.4m+54mヘビーリフトジブ

オフセット	10°	20°	30°	45°	60°
作業半径 (m)	荷重 (ton)	荷重 (ton)	荷重 (ton)	荷重 (ton)	荷重 (ton)
24.0	3.5				
26.0	3.5				
28.0	3.5				
30.0	3.5				
32.0	3.5				
34.0	3.5	3.3			
36.0	3.5	3.1			
38.0	3.5	3.0			
40.0	3.5	2.9	2.2		
42.0	3.4	2.8	2.1		
44.0	3.3	2.7	2.0		
46.0	3.2	2.5	2.0		
48.0	3.0	2.5	1.9		
50.0		2.4	1.8		
55.0		2.2	1.7		
60.0			1.6		
危険角度 (°)	68	69	70		
フック種類	12t	12t	12t		
フック質量 (t)	0.53	0.53	0.53		
掛数	1	1	1		